

PHVL Supercapacitors

Cylindrical packs

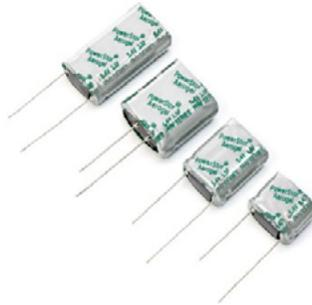

Description

Eaton supercapacitors are high reliability, high power, ultra-high capacitance energy storage devices utilizing electric double layer capacitor (EDLC) construction combined with proprietary materials and processes. This combination of advanced technologies allows Eaton to offer a wide variety of capacitor solutions tailored to applications for backup power, pulse power and hybrid power systems.

They can be applied as the sole energy storage or in combination with batteries to optimize cost, life time and run time. System requirements can range from a few microwatts to megawatts.

All products feature low ESR for high power density with environmentally friendly materials for a green power solution. Eaton supercapacitors are maintenance-free with design lifetimes up to 20 years* and operating temperatures down to -40 °C and up to +85 °C.

Features and benefits

- Low leakage current, low self discharge
- Large capacitance for high energy density
- Ultra-low ESR for high power density

Applications

- Pulse Power
- Water and gas meters
- Battery assist for peak power
 - Especially Lithium Thionyl (15 year life)
- IoT sensors
- Long duration discharges
 - RTC
 - Memory backup
- Bridging or hold-up power

Environmental compliance



*Supercapacitor lifetimes vary based on charge voltage and temperature. See Eaton's application guidelines or contact your local Eaton sales representative for more information on lifetime estimates

Ratings

Capacitance	0.47 F to 5.0 F
Working voltage ⁸	3.9 V
Surge voltage ⁸	5.0 V
Capacitance tolerance	-10% to +30% (+20 °C)
Operating temperature range	-40 °C to +65 °C
Extended operating temperature range	-40 °C to +85 °C

Specifications

Capacitance ¹ (F)	Vertical part number	Horizontal part number	Maximum initial ESR ¹ (Ω)	Peak current ⁵ (A)	Nominal leakage current ² (μA)	Peak power ⁴ (W)	Stored energy ³ (mWh)	Short circuit current ^{**6} (A)
0.47	PHVL-3R9V474-R	PHVL-3R9H474-R	0.40	0.77	1.0	9.5	0.993	9.75
1.5	PHVL-3R9V155-R	PHVL-3R9H155-R	0.16	2.35	2.0	23.8	3.17	24.3
2.5	PHVL-3R9V255-R	PHVL-3R9H255-R	0.08	4.06	4.0	47.5	5.28	48.8
3.0	PHVL-3R9V305-R	PHVL-3R9H305-R	0.08	4.71	4.0	47.5	6.34	48.8
5.0	PHVL-3R9V505-R	PHVL-3R9H505-R	0.07	7.22	5.0	54.3	10.6	55.7

** Repeated short circuit current will permanently damage the leads.

Performance

Parameter	Capacitance change (% of initial value)	ESR (% of maximum initial value)
Lifetime: (3.9 V; 2 years @ +65 °C, 5,000 hours @ +85 °C)	≤ 30%	≤ 200%
Charge/discharge cycles ⁷ : (500,000 at +20 °C)	≤ 30%	≤ 200%
Storage: Low and high temperature (1000 hours @ -40 °C and +85 °C)	≤ 30%	≤ 200%

1. Capacitance, Equivalent series resistance (ESR) and leakage current are measured according to IEC62391-1

2. Leakage current at +20 °C after 72 hour charge and hold.

3. Stored energy (mWh) = $\frac{0.5 \times V^2 \times C}{3600} \times 1000$

4. Peak power (W) = $\frac{V^2}{4 \times \text{ESR}}$

5. Pulse current for 1 second from full rate voltage to half voltage.(A) = $\frac{0.5 \times V \times C}{(1 + \text{ESR} \times C)}$

6. Short circuit current is for safety information only. Do not use as operating current.

7. Cycling between rated voltage and half voltage, 3 second rest at +20 °C.

8. Voltage testing and verification of product under end application conditions is recommended

Safety and certifications

Environmental compliance	RoHS, REACH, lead free, halogen free
Warnings	Do not overvoltage, do not reverse polarity
Shipping	No restrictions, per UN3499 with all cells <10 watt-hours

Vertical part number	Horizontal part number	A	B	C	d'	D	D'	E	E'	F	P	Typical mass (g)
PHVL-3R9V474-R	PHVL-3R9H474-R	9.0	17.3	14.5	0.5	20	15	25	20	2.0	11.8	2.6
PHVL-3R9V155-R	PHVL-3R9H155-R	9.0	17.3	22	0.5	20	15	25	20	2.0	11.8	3.0
PHVL-3R9V255-R	PHVL-3R9H255-R	11	21.3	23	0.6	20	15	25	20	2.0	5.3	4.5
PHVL-3R9V305-R	PHVL-3R9H305-R	9.0	17.3	32.5	0.5	20	15	25	20	2.0	11.8	4.8
PHVL-3R9V505-R	PHVL-3R9H505-R	11	21.3	32.5	0.6	20	15	25	20	2.0	5.3	6.8
Tolerances		Maximum			± 0.02	Minimum				± 0.5		

Note: Longer lead is positive

Vertical

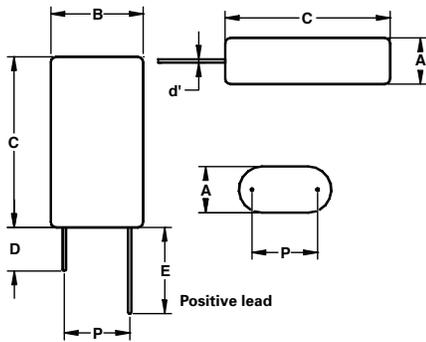

Horizontal

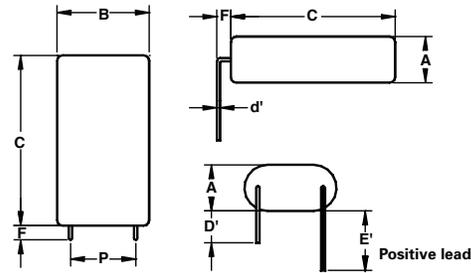

Part numbering system

P	HVL	-3R9	V	15	5	-R
Type	Family code	Voltage (V) R = decimal	Configuration	Capacitance (µF) Value	Multiplier	Standard product
P = Pack	HVL= Product family	3R9 = 3.9 V	V= Vertical H= Horizontal	Example 155= 15 x 10 ⁵ µF or 1.5 F		

Packaging information

- Standard packaging: Bulk, 100 parts per bag

Part marking

- Manufacturer
- Capacitance value (F)
- Working voltage (V)
- Family code or part number
- Polarity mark
-