

**3.3V, 4-Bit, 2-Port Nanoswitchw/Individual Enables**

**Features**

- Near zero propagation delay
- 5 Ohm switches connect inputs to outputs
- Fast Switching Speed - 4ns max.
- Ultra Low Quiescent Power (0.1µA Typical)
  - Ideally suited for notebook applications
- Packages available:
  - 14-pin, SOIC (W)
  - 14-pin, TSSOP (L)
  - 14-pin, TQFN (ZDB)
  - 16-pin, QSOP (Q)

**Description**

Diodes' PI3B series of logic circuits are produced using the Company's advanced sub micron CMOS technology, achieving industry leading speed grades.

The PI3B3125 and PI3B3126 are 3.3 Volt, 4-bit bus switches designed with four individual 5 Ohm bus switches with fast individual enables in an industry standard 74XX125/126 pinout. When enabled via the associated Bus Enable ( $\overline{BE}$ ) pin, the "A" pin is directly connected to the "B" pin for that particular gate. The bus switch introduces no additional propagation delay or additional ground bounce noise.

The PI3B3125 device has active LOW enables, and the PI3B3126 has active HIGH enables.

**PI3B3125 Logic Block Diagram**

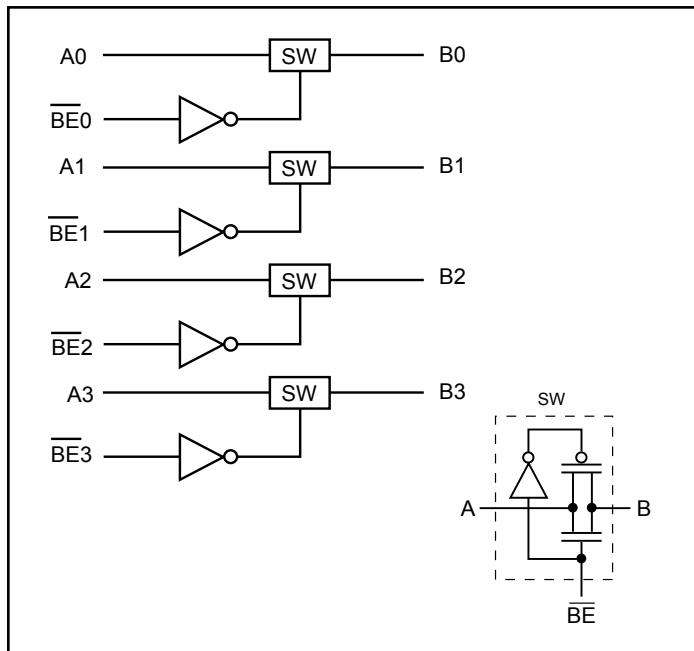

**PI3B3126 Logic Block Diagram**

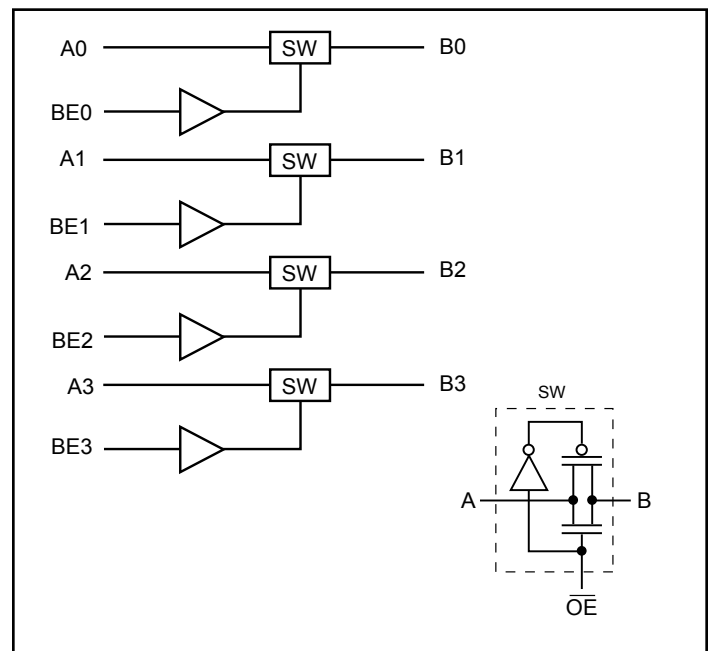

**PI3B3125**  
**14-Pin Product Configuration (SOIC, TSSOP)**

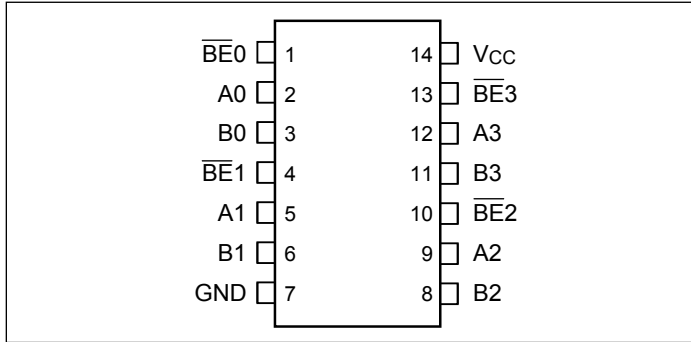

**PI3B3126**  
**14-Pin Product Configuration (SOIC, TSSOP)**



**PI3B3125**  
**16-Pin Product Configuration (QSOP)**

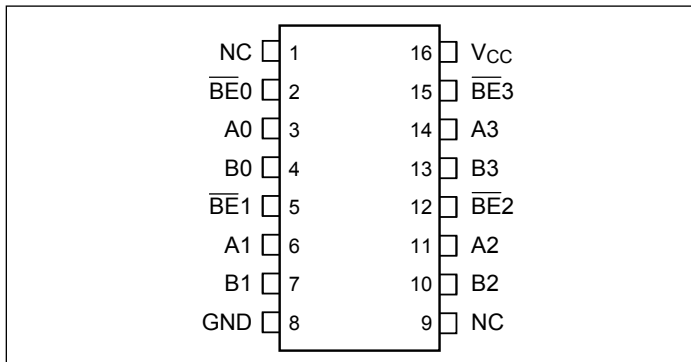

**PI3B3126**  
**14-Pin Product Configuration (TQFN)**



**Pin Description**

Pin Name	Description
$\overline{\text{BE}}_n$	Switch Enable (PI3B3125)
$\text{BE}_n$	Switch Enable (PI3B3126)
A3-A0	Bus A
B3-B0	Bus B
$V_{CC}$	Power
GND	Ground

**PI3B3126**  
**16-Pin Product Configuration (QSOP)**

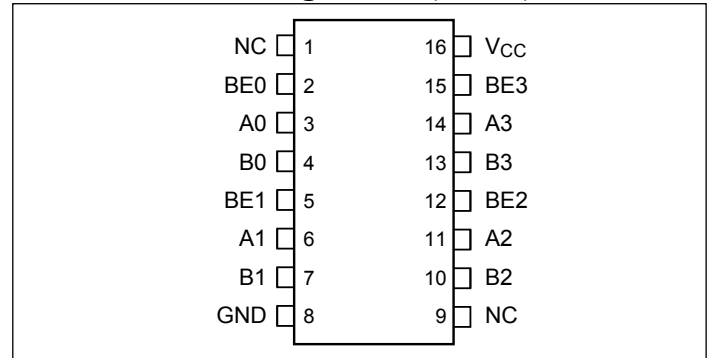

**Truth Table<sup>(1)</sup>**

PI3B3125	PI3B3126	$\overline{\text{BE}}_n$	$\text{BE}_n$	$A_n$	$B_n$	$V_{CC}$	Function
		X <sup>(2)</sup>	X	Hi-Z	Hi-Z	GND	Disconnect
		H	L	Hi-Z	Hi-Z	$V_{CC}$	Disconnect
		L	H	$B_n$	$A_n$	$V_{CC}$	Connect

**Notes:**

- H = High Voltage Level, L = Low Voltage Level  
HI-Z = High Impedance, X = Don't Care
- A pull-up resistor should be provided for power-up protection.

## Maximum Ratings

(Above which the useful life may be impaired. For user guidelines, not tested.)

Storage Temperature .....	-65°C to +150°C
Ambient Temperature with Power Applied .....	-40°C to +85°C
Supply Voltage to Ground Potential.....	-0.5V to +4.6V
DC Input Voltage .....	-0.5V to +4.6V
DC Output Current.....	120mA
Power Dissipation.....	0.5W

**Note:**

Stresses greater than those listed under MAXIMUM RATINGS may cause permanent damage to the device. This is a stress rating only and functional operation of the device at these or any other conditions above those indicated in the operational sections of this specification is not implied. Exposure to absolute maximum rating conditions for extended periods may affect reliability.

## DC Electrical Characteristics

(Over the Operating Range,  $T_A = -40^\circ\text{C}$  to  $+85^\circ\text{C}$ ,  $V_{CC} = 3.3\text{V} \pm 10\%$ )

Parameter	Description	Test Conditions <sup>(1)</sup>	Min.	Typ. <sup>(2)</sup>	Max.	Units
$V_{IH}$	Input HIGH Voltage	Guaranteed Logic HIGH Level	2.0			V
$V_{IL}$	Input LOW Voltage	Guaranteed Logic LOW Level	-0.5		0.8	V
$I_{IH}$	Input HIGH Current	$V_{CC} = \text{Max.}, V_{IN} = V_{CC}$			$\pm 1$	MA
$I_{IL}$	Input LOW Current	$V_{CC} = \text{Max.}, V_{IN} = \text{GND}$			$\pm 1$	MA
$I_{OFF}$	Off Current	$V_{CC} = 0, V_{OUT} = 3$ to $3.6\text{V}$			10	MA
$V_{IK}$	Clamp Diode Voltage	$V_{CC} = \text{Min.}, I_{IN} = -18\text{mA}$			-1.2	V
$R_{ON}$	Switch On Resistance <sup>(3)</sup>	$V_{CC} = \text{Min.}, V_{IN} = 0.0\text{V}, I_{ON} = 48\text{mA}$ or $60\text{mA}$		5	8	$\Omega$
		$V_{CC} = \text{Min.}, V_{IN} = 2.4\text{V}, I_{ON} = 15\text{mA}$		10	17	

**Notes:**

- For Max. or Min. conditions, use appropriate value specified under Electrical Characteristics for the applicable device type.
- Typical values are at  $V_{CC} = 3.3\text{V}$ ,  $T_A = 25^\circ\text{C}$  ambient and maximum loading.
- Measured by the voltage drop between A and B pin at indicated current through the switch. ON resistance is determined by the lower of the voltages on the two (A, B) pins.

## Capacitance

( $T_A = 25^\circ\text{C}$ ,  $f = 1\text{MHz}$ )

Parameter <sup>(1)</sup>	Description	Test Conditions	Min.	Typ.	Max.	Units
$C_{IN}$	Input Capacitance	$V_{IN} = 0\text{V}$		3.5		pF
$C_{OFF}$	A/B Capacitance, Switch Off	$V_{IN} = 0\text{V}$		8		pF

**Note:**

- This parameter is determined by device characterization but is not production tested.

## Power Supply Characteristics

Parameter	Description	Test Conditions <sup>(1)</sup>		Min.	Typ. <sup>(2)</sup>	Max.	Units
$I_{CC}$	Quiescent Power Supply Current	$V_{CC} = \text{Max.}$	$V_{IN} = \text{GND}$ or $V_{CC}$		0.1	3	$\mu\text{A}$
$\Delta I_{CC}$	Supply Current per Input HIGH	$V_{CC} = \text{Max.}$	$V_{IN} = 3.0\text{V}^{(3)}$			750	$\mu\text{A}$

**Notes:**

- For Max. or Min. conditions, use appropriate value specified under Electrical Characteristics for the applicable device.
- Typical values are at  $V_{CC} = 3.3\text{V}$ ,  $+25^\circ\text{C}$  ambient.
- Per driven input (control inputs only); A and B pins do not contribute to  $I_{CC}$ .

### PI3B3125 Switching Characteristics over Operating Range

Parameter	Description	Conditions <sup>(1)</sup>	PI3B3125		Units
			Com.		
			Min.	Max.	
t <sub>PLH</sub> t <sub>PHL</sub>	Propagation Delay <sup>(2,3)</sup> Ax to Bx, Bx to Ax	C <sub>L</sub> = 50pF R <sub>L</sub> = 500Ω		0.25	ns
t <sub>PZH</sub> t <sub>PZL</sub>	Bus Enable Time	C <sub>L</sub> = 50pF R <sub>L</sub> = 500Ω	1.0	3.0	ns
t <sub>PHZ</sub> t <sub>PLZ</sub>	Bus Disable Time	R <sub>L</sub> = 500Ω	1.0	4.0	ns

### PI3B3126 Switching Characteristics over Operating Range

Parameter	Description	Conditions <sup>(1)</sup>	PI3B3126		Units
			Com.		
			Min.	Max.	
t <sub>PLH</sub> t <sub>PHL</sub>	Propagation Delay <sup>(2,3)</sup> Ax to Bx, Bx to Ax	C <sub>L</sub> = 50pF R <sub>L</sub> = 500Ω		0.25	ns
t <sub>PZH</sub> t <sub>PZL</sub>	Bus Enable Time	C <sub>L</sub> = 50pF R <sub>L</sub> = 500Ω	1.0	2.5	ns
t <sub>PHZ</sub> t <sub>PLZ</sub>	Bus Disable Time	R <sub>L</sub> = 500Ω	1.0	4.0	ns

**Notes:**

1. See test circuit and waveforms.
2. This parameter is guaranteed but not tested on Propagation Delays.
3. The bus switch contributes no propagational delay other than the RC delay of the ON resistance of the switch and the load capacitance. The time constant for the switch alone is of the order of 0.25ns for 50pF load. Since this time constant is much smaller than the rise/fall times of typical driving signals, it adds very little propagational delay to the system. Propagational delay of the bus switch when used in a system is determined by the driving circuit on the driving side of the switch and its interaction with the load on the driven side.

## Applications Information

### Logic Inputs

The logic control inputs can be driven up to +3.6V regardless of the supply voltage. For example, given a + 3.3V supply, IN may be driven low to 0V and high to 3.6V. Driving IN Rail-to-Rail® minimizes power consumption.

### Power-Supply Sequencing and Hot-Plug Information

Proper power-supply sequencing is recommended for all CMOS devices. Always apply V<sub>CC</sub> and GND before applying signals to input/output or control pins.

*Rail-to-Rail is a registered trademark of Nippon Motorola, Ltd.*

**PI3B3125 Part Marking**

L Package

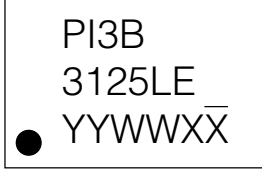

YY: Year  
WW: Workweek  
1st X: Assembly Site Code  
2nd X: Fab Site Code

Q Package

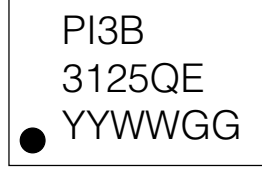

YY: Year  
WW: Workweek  
1st G: Assembly Site Code  
2nd G: Wafer Fab Site Code

W Package



YY: Year  
WW: Workweek  
1st X: Assembly Site Code  
2nd X: Wafer Fab Site Code

**PI3B3126 Part Marking**

L Package

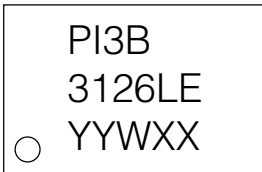

1st Y: Die Rev  
2nd Y: Year  
W: Workweek  
1st X: Assembly Code  
2nd X: Fab Code

Q Package

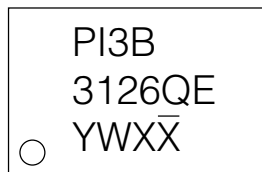

Y: Year  
W: Workweek  
1st X: Assembly Site Code  
2nd X: Fab Site Code

W Package



YY: Year  
WW: Workweek  
1st X: Assembly Site Code  
2nd X: Wafer Fab Site Code

ZDB Package



YY: Year  
WW: Workweek  
1st X: Assembly Site Code  
2nd X: Fab Site Code

**Packaging Mechanical: 14-TSSOP (L)**

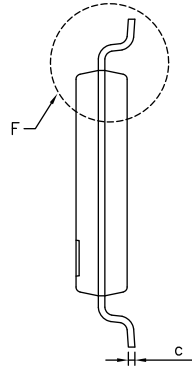

SYMBOLS	MIN.	NOM.	MAX.
A	–	–	1.20
A1	0.05	–	0.15
A2	0.80	1.00	1.05
b	0.19	–	0.30
c	0.09	–	0.20
D	4.90	5.00	5.10
E1	4.30	4.40	4.50
E	6.20	6.40	6.60
e	0.65 BSC		
L1	1.00 REF		
L	0.45	0.60	0.75
S	0.20	–	–
$\theta$	0°	–	8°

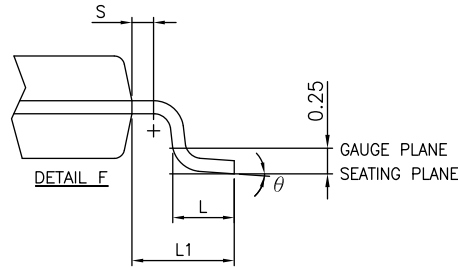

- NOTES:  
 1. ALL DIMENSIONS IN MILLIMETERS. ANGLES IN DEGREES.  
 2. JEDEC MO-153F  
 3. DIMENSIONS DOES NOT INCLUDE MOLD FLASH, PROTRUSIONS OR GATE BURRS.

<b>PERICOM</b> Enabling Serial Connectivity	DATE: 03/24/16
DESCRIPTION: 14-Pin, 173mil Wide TSSOP	
PACKAGE CODE: L (L14)	
DOCUMENT CONTROL #: PD-1309	REVISION: E

16-0060

**PI3B3125/PI3B3126**

**Packaging Mechanical: 14-SOIC (W)**



NOTES:  
 1. ALL DIMENSIONS ARE IN mm. ANGLES IN DEGREES.  
 2. JEDEC MS-012  
 3. DIMENSIONS DOES NOT INCLUDE MOLD FLASH, PROTRUSIONS OR GATE BURRS.

<b>PERICOM</b> Enabling Serial Connectivity	DATE: 03/24/16
DESCRIPTION: 14-Pin, 150mil Wide SOIC	
PACKAGE CODE: W (W14)	
DOCUMENT CONTROL #: PD-1002	REVISION: E

16-0055

**PI3B3125/PI3B3126**

**Packaging Mechanical: 16-QSOP (Q)**

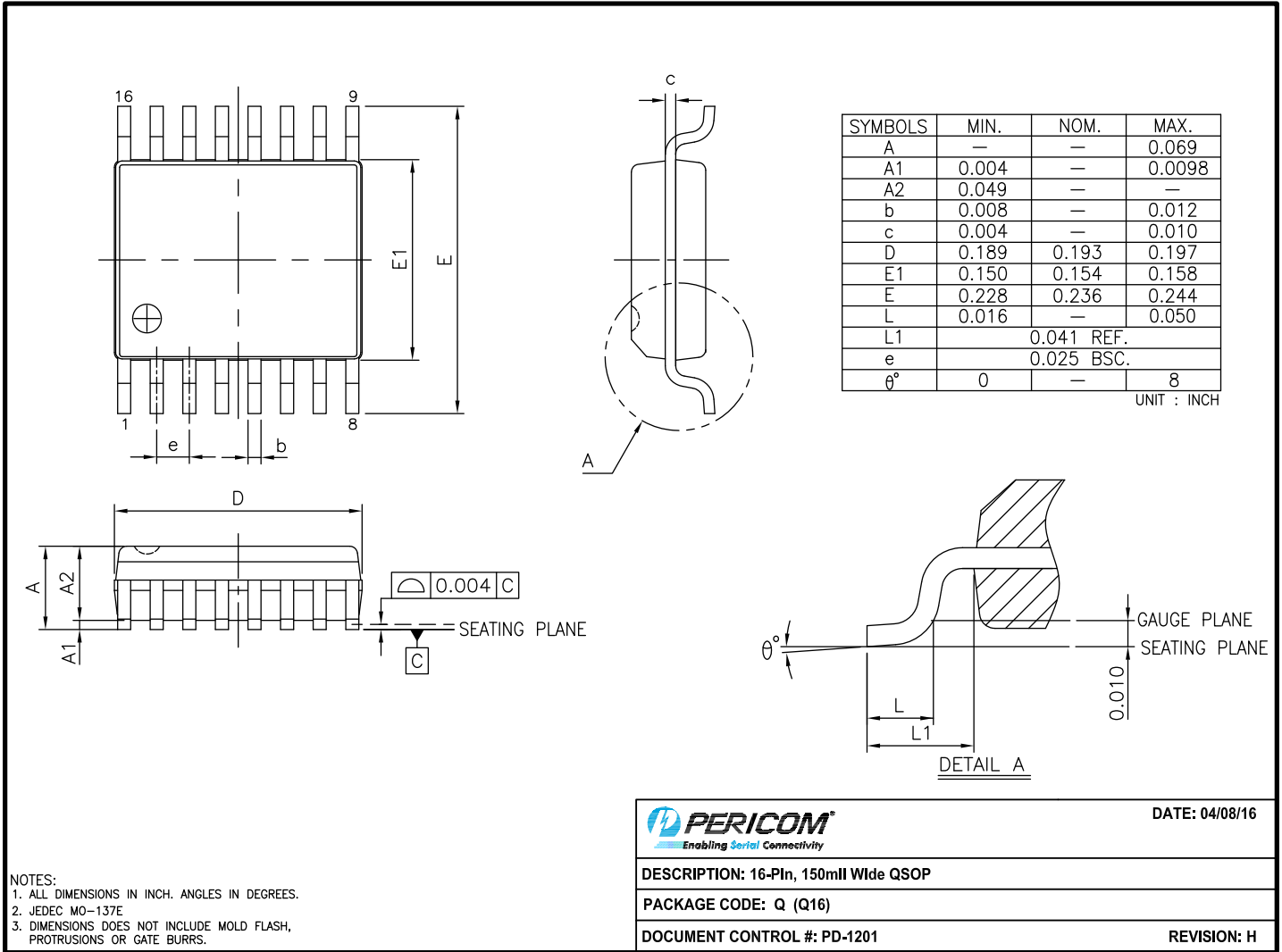

16-0056

<b>PERICOM</b> Enabling Serial Connectivity	DATE: 04/08/16
DESCRIPTION: 16-Pin, 150mil Wide QSOP	
PACKAGE CODE: Q (Q16)	
DOCUMENT CONTROL #: PD-1201	REVISION: H



**Packaging Mechanical: 14-TQFN (ZDB)**

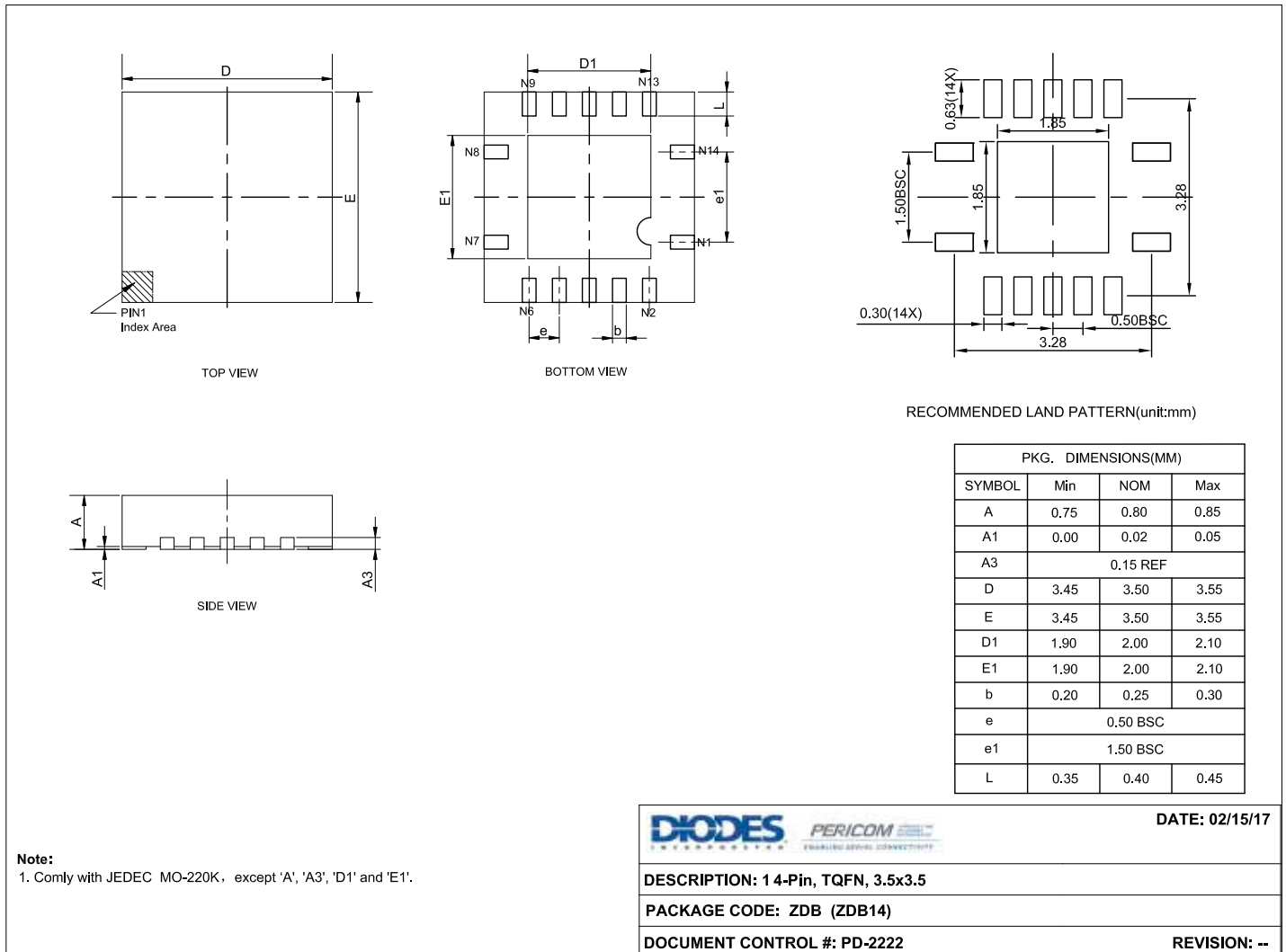

17-0029

**For latest package info.**

please check: <http://www.diodes.com/design/support/packaging/pericom-packaging/packaging-mechanicals-and-thermal-characteristics/>

**Ordering Information**

Ordering Code	Package Code	Package Description
PI3B3125LEX	L	14-Pin, 173mil Wide (TSSOP)
PI3B3125WEX	W	14-Pin, 150mil Wide (SOIC)
PI3B3125QEX	Q	16-Pin, 150mil Wide(QSOP)
PI3B3126LEX	L	14-Pin, 173mil Wide (TSSOP)
PI3B3126WEX	W	14-Pin, 150mil Wide (SOIC)
PI3B3126QEX	Q	16-Pin, 150mil Wide(QSOP)
PI3B3126ZDBEX	ZDB	16-Pin, 3.5x3.5 (TQFN)

**Notes:**

- EU Directive 2002/95/EC (RoHS), 2011/65/EU (RoHS 2) & 2015/863/EU (RoHS 3) compliant. All applicable RoHS exemptions applied.
- See <http://www.diodes.com/quality/lead-free/> for more information about Diodes Incorporated's definitions of Halogen- and Antimony-free, "Green" and Lead-free. Thermal characteristics can be found on the company web site at [www.diodes.com/design/support/packaging/](http://www.diodes.com/design/support/packaging/)
- E = Pb-free and Green
- X suffix = Tape/Reel