

4-Channel 2:1 Mux/DeMux, Enable Low 1.8V/2.5V/3.3V, High-Bandwidth, Hot Plug

Features

- Near-Zero Propagation Delay
- 5Ω Switches Connect Inputs to Outputs
- High Signal Passing Bandwidth (500MHz)
- Beyond Rail-to-Rail Switching
 - 0 to 5V Switching with 3.3V Power Supply
 - 0 to 3.3V Switching with 2.5V Power Supply
- 5V I/O Tolerant with Supply in OFF and ON State
- 1.8V, 2.5V and 3.3V Supply Voltage Operation
- Hot Insertion Capable
- Industrial Operating Temperature: -40°C to +85°C
- 8kV ESD Protection (Human Body Model)
- Latch-up Performance: >200mA per JESD17
- Totally Lead-Free & Fully RoHS Compliant (Notes 1 & 2)
- Halogen and Antimony Free. “Green” Device (Note 3)
- For automotive applications requiring specific change control (i.e. parts qualified to AEC-Q100/101/200, PPAP capable, and manufactured in IATF 16949 certified facilities), please [contact us](https://www.diodes.com/contact-us) or your local Diodes representative.
<https://www.diodes.com/quality/product-definitions>
- Packaging (Pb-free & Green available):
 - 16-pin 173-mil Wide Plastic TSSOP (L)
 - 16-pin 150-mil Wide Plastic QSOP (Q)
 - 16-pin UQFN3x3-16(ZHD)

Block Diagram

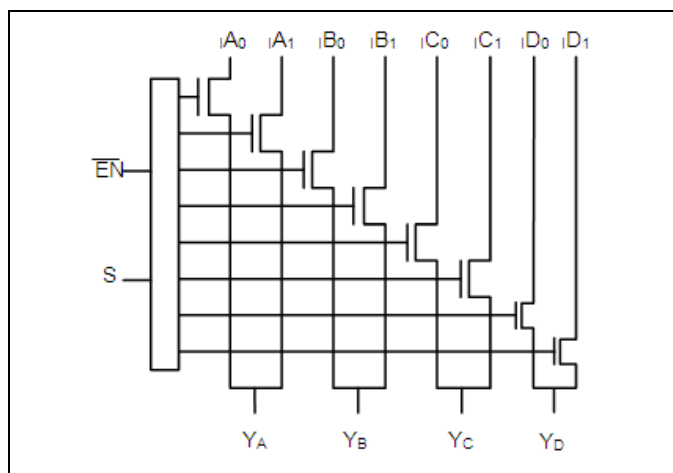

Notes:
 1. No purposely added lead. Fully EU Directive 2002/95/EC (RoHS), 2011/65/EU (RoHS 2) & 2015/863/EU (RoHS 3) compliant.
 2. See <https://www.diodes.com/quality/lead-free/> for more information about Diodes Incorporated's definitions of Halogen- and Antimony-free, "Green" and Lead-free.
 3. Halogen- and Antimony-free "Green" products are defined as those which contain <900ppm bromine, <900ppm chlorine (<1500ppm total Br + Cl) and <1000ppm antimony compounds.

Description

The PI3CH480 is a 4-channel, 2:1 Multiplexer/De-multiplexer with tri-state outputs. The switch introduces no additional ground bounce noise or propagation delay.

The PI3CH480 device is very useful in switching signals that have high bandwidth (500 MHz).

Truth Table

$\overline{\text{EX}}$	S	YA	YB	YC	YD	Function
H	X	Hi-Z	Hi-Z	Hi-Z	Hi-Z	Disable
L	L	IA0	IB0	IC0	ID0	S=0
L	H	IA1	IB1	IC1	ID1	S=1

Note: H=High Voltage Level; L=Low Voltage Level

Pin Configuration

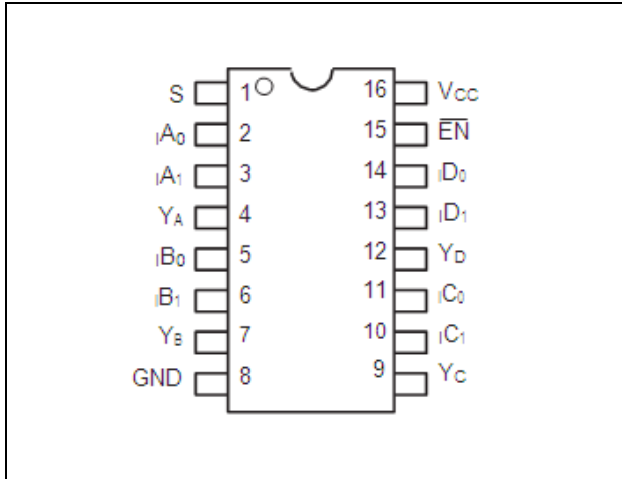

TSSOP/QSOP Top View

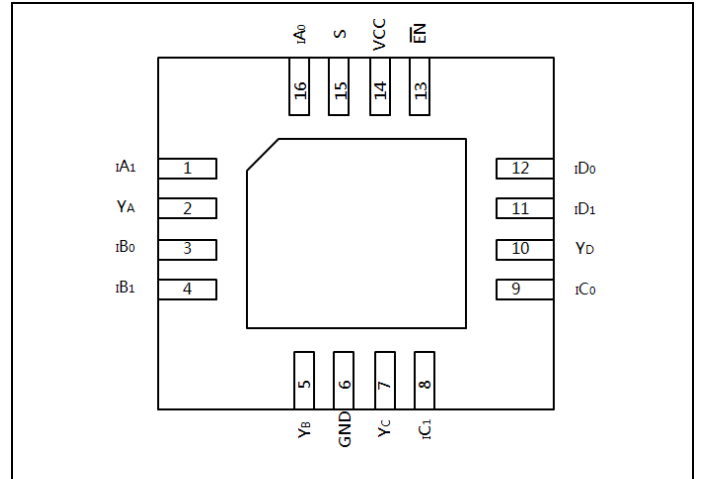

UQFN3x3-16 Top View

Pin Description

TSSOP/QSOP Pin#	UQFN Pin#	Pin Name	Description
1	15	S	Select Inputs
2, 3, 5, 6, 11, 10, 14, 13	16, 1, 3, 4, 9, 8, 12, 11	$iA_0, iA_1, iB_0, iB_1,$ iC_0, iC_1, iD_0, iD_1	Data Inputs
4, 7, 9, 12	2, 5, 7, 10	Y_A, Y_B, Y_C, Y_D	Data Outputs
8	6	GND	Ground
15	13	\overline{EN}	Enable
16	14	VCC	Power
—	Center Pad	GND	—

Maximum Ratings

Storage Temperature	-65°C to +150°C
Supply Voltage to Ground Potential	-0.5V to +4.6V
DC Input Voltage	-0.5V to +6.0V
DC Output Current	120mA
Power Dissipation	0.5W
Junction Temperature (T _J)	125°C

Note:

Stresses greater than those listed under MAXIMUM RATINGS may cause permanent damage to the device. This is a stress rating only and functional operation of the device at these or any other conditions above those indicated in the operational sections of this specification is not implied. Exposure to absolute maximum rating conditions for extended periods may affect reliability.

DC Electrical Characteristics

3.3V Supply (Over Operating Range, T_A = -40°C ~ +85°C, V_{CC} = 3.3V ± 10%, unless otherwise noted)

Symbol	Description	Test Conditions ⁽¹⁾	Min	Typ ⁽²⁾	Max	Unit
V _{IH}	Control Input HIGH Voltage	Guaranteed Logic HIGH Level	2.0	—	—	V
V _{IL}	Control Input LOW Voltage	Guaranteed Logic LOW Level	-0.5	—	0.8	V
V _{IK}	Clamp Diode Voltage	V _{CC} = Min., I _{IN} = -18mA	—	-1.3	-1.8	V
I _{IH}	Input HIGH Current	V _{CC} = Max., V _{IN} = V _{CC}	—	—	±1	μA
I _{IL}	Input Low Current	V _{CC} = Max., V _{IN} = GND	—	—	±1	μA
I _{OZH}	High-Impedance Current ⁽³⁾	0 ≤ Y, I _n ≤ V _{CC}	—	—	±1	μA
R _{ON}	Switch On-Resistance ⁽⁴⁾	V _{CC} = Min., V _{IN} = 0.0V I _{ON} = -48mA or -64mA	—	4	6	Ω
		V _{CC} = Min., V _{IN} = 3.6V I _{ON} = -15mA	—	5	8	

Notes:

- For maximum or minimum conditions, use appropriate value specified under Electrical Characteristics for the applicable device type.
- Typical values are at V_{CC} = 3.3V, T_A = 25°C ambient and maximum loading.
- Not more than one output should be shorted at one time. Duration of the test should not exceed one second.
- Measured by the voltage drop between Y and In pin at indicated current through the switch. ON resistance is determined by the lower of the voltages on the two (Y, In) pins.

2.5V Supply (Over Operating Range, T_A = -40°C ~ +85°C, V_{CC} = 2.5V ± 10%, unless otherwise noted)

Symbol	Description	Test Conditions ⁽¹⁾	Min	Typ ⁽²⁾	Max	Unit
V _{IH}	Control Input HIGH Voltage	Guaranteed Logic HIGH Level	1.8	—	V _{CC} +0.3	V
V _{IL}	Control Input LOW Voltage	Guaranteed Logic LOW Level	-0.3	—	0.8	V
V _{IK}	Clamp Diode Voltage	V _{CC} = Max., I _{IN} = -6mA	—	-0.7	-1.8	V
I _{IH}	Input HIGH Current	V _{CC} = Max., V _{IN} = V _{CC}	—	—	±1	μA
I _{IL}	Input Low Current	V _{CC} = Max., V _{IN} = GND	—	—	±1	μA
I _{OZH}	High-Impedance Current ⁽³⁾	0 ≤ Y, I _n ≤ V _{CC}	—	—	±1	μA
R _{ON}	Switch On-Resistance ⁽⁴⁾	V _{CC} = Min., V _{IN} = 0.0V I _{ON} = -48mA	—	4	8	Ω
		V _{CC} = Min., V _{IN} = 2.25V I _{ON} = -15mA	—	7	14	

Notes:

- For maximum or minimum conditions, use appropriate value specified under Electrical Characteristics for the applicable device type.
- Typical values are at V_{CC} = 2.5V, T_A = 25°C ambient and maximum loading.
- Not more than one output should be shorted at one time. Duration of the test should not exceed one second.
- Measured by the voltage drop between Y and In pin at indicated current through the switch. ON resistance is determined by the lower of the voltages on the two (Y, In) pins.

1.8V Supply (Over Operating Range, $T_A = -40^\circ\text{C} \sim +85^\circ\text{C}$, $V_{CC} = 1.8\text{V} \pm 10\%$, unless otherwise noted)

Symbol	Description	Test Conditions ⁽¹⁾	Min	Typ ⁽²⁾	Max	Unit
V_{IH}	Control Input HIGH Voltage	Guaranteed Logic HIGH Level	1.2	—	$V_{CC}+0.3$	V
V_{IL}	Control Input LOW Voltage	Guaranteed Logic LOW Level	-0.3	—	0.6	V
V_{IK}	Clamp Diode Voltage	$V_{CC} = \text{Max.}, I_{IN} = -18\text{mA}$	—	-0.7	-1.8	V
I_{IH}	Input HIGH Current	$V_{CC} = \text{Max.}, V_{IN} = V_{CC}$	—	—	± 1	μA
I_{IL}	Input Low Current	$V_{CC} = \text{Max.}, V_{IN} = \text{GND}$	—	—	± 1	μA
I_{OZH}	High-Impedance Current ⁽³⁾	$0 \leq Y, I_n \leq V_{CC}$	—	—	± 1	μA
R_{ON}	Switch On-Resistance ⁽⁴⁾	$V_{CC} = \text{Min.}, V_{IN} = 0.0\text{V}$ $I_{ON} = -48\text{mA}$	—	4	8	Ω
		$V_{CC} = \text{Min.}, V_{IN} = 1.6\text{V}$ $I_{ON} = -15\text{mA}$	—	10	25	

Notes:

- For maximum or minimum conditions, use appropriate value specified under Electrical Characteristics for the applicable device type.
- Typical values are at $V_{CC} = 1.8\text{V}$, $T_A = 25^\circ\text{C}$ ambient and maximum loading.
- Not more than one output should be shorted at one time. Duration of the test should not exceed one second.
- Measured by the voltage drop between Y and In pin at indicated current through the switch. ON resistance is determined by the lower of the voltages on the two (Y, In) pins.

Capacitance ($T_A = 25^\circ\text{C}$, $f = 1\text{MHz}$)

Symbol ⁽¹⁾	Description	Test Conditions	Typ.	Max.	Unit
C_{IN}	Input Capacitance	$V_{IN} = 0\text{V}$	1.6	2.5	pF
$C_{OFF(IN)}$	In Capacitance, Switch Off		3.2	4.5	
$C_{OFF(Y)}$	Y Capacitance, Switch Off		4.9	6.5	
C_{ON}	Y/In Capacitance, Switch On		8.4	10	

Note:

- These parameters are determined by device characterization but are not production tested

Power Supply Characteristics

Symbol	Description	Test Conditions ⁽¹⁾	Min	Typ	Max	Unit
I_{CC}	Quiescent Power Supply Current	$V_{CC} = 3.6\text{V}, V_{IN} = \text{GND or } V_{CC}$	—	0.2	0.5	mA
		$V_{CC} = 2.5\text{V}, V_{IN} = \text{GND or } V_{CC}$	—	0.25	0.6	mA
		$V_{CC} = 1.8\text{V}, V_{IN} = \text{GND or } V_{CC}$	—	0.8	1.5	mA

Note:

- For maximum or minimum conditions, use appropriate value specified under Electrical Characteristics for the applicable device.

Dynamic Electrical Characteristics

 (Over Operating Range, $T_A = -40^\circ\text{C} \sim +85^\circ\text{C}$, $V_{CC} = 3.3\text{V} \pm 10\%$)

Symbol	Description	Test Conditions	Min	Typ	Max	Unit
X_{TALK}	Crosstalk	See Test Diagram	—	-60	—	dB
O_{IRR}	Off-Isolation	See Test Diagram	—	-60	—	
BW	-3dB Bandwidth	See Test Diagram	200	500	—	MHz

Switch Characteristics

Over 3.3V Operating Range

Symbol	Description	Test Conditions ⁽¹⁾	Min	Typ	Max	Unit
t_{PLH} , t_{PHL}	Propagation Delay ^(2, 3) Y to In, In to Y	See Test Diagram	—	—	0.3	ns
t_{PZH} , t_{PZL}	Enable Time S or \overline{EN} to Y or In	See Test Diagram	1.5	—	9.0	
t_{PHZ} , t_{PLZ}	Disable Time S or \overline{EN} to Y or In	See Test Diagram	1.5	—	9.0	

Note:

1. See test circuit and waveforms.
2. This parameter is guaranteed but not tested on propagation delays.
3. The switch contributes no propagation delay other than the RC delay of the on-resistance of the switch and the load capacitance. The time constant for the switch alone is of the order of 0.30ns for 10pF load. Because this time constant is much smaller than the rise/fall times of typical driving signals, it adds very little propagation delay to the system. Propagation delay of the switch when used in a system is determined by the driving circuit on the driving side of the switch and its interaction with the load on the driven side.

Over 2.5V Operating Range

Symbol	Description	Test Conditions ⁽¹⁾	Min	Typ	Max	Unit
t_{PLH} , t_{PHL}	Propagation Delay ^(2, 3) Y to In, In to Y	See Test Diagram	—	—	0.3	ns
t_{PZH} , t_{PZL}	Enable Time S or \overline{EN} to Y or In	See Test Diagram	1.5	—	15.0	
t_{PHZ} , t_{PLZ}	Disable Time S or \overline{EN} to Y or In	See Test Diagram	1.5	—	12.0	

Note:

1. See test circuit and waveforms.
2. This parameter is guaranteed but not tested on propagation delays.
3. The switch contributes no propagation delay other than the RC delay of the on-resistance of the switch and the load capacitance. The time constant for the switch alone is of the order of 0.30ns for 10pF load. Because this time constant is much smaller than the rise/fall times of typical driving signals, it adds very little propagation delay to the system. Propagation delay of the switch when used in a system is determined by the driving circuit on the driving side of the switch and its interaction with the load on the driven side.

Over 1.8V Operating Range

Symbol	Description	Test Conditions ⁽¹⁾	Min	Typ	Max	Unit
t_{PLH} , t_{PHL}	Propagation Delay ^(2, 3) Y to In, In to Y	See Test Diagram	—	—	0.3	ns
t_{PZH} , t_{PZL}	Enable Time S or \overline{EN} to Y or In	See Test Diagram	1.5	—	25.0	
t_{PHZ} , t_{PLZ}	Disable Time S or \overline{EN} to Y or In	See Test Diagram	1.5	—	12.0	

Notes:

1. See test circuit and waveforms.
2. This parameter is guaranteed but not tested on propagation delays.
3. The switch contributes no propagation delay other than the RC delay of the on-resistance of the switch and the load capacitance. The time constant for the switch alone is of the order of 0.30ns for 10pF load. Because this time constant is much smaller than the rise/fall times of typical driving signals, it adds very little propagation delay to the system. Propagation delay of the switch when used in a system is determined by the driving circuit on the driving side of the switch and its interaction with the load on the driven side.

Test Circuit for Electrical Characteristics

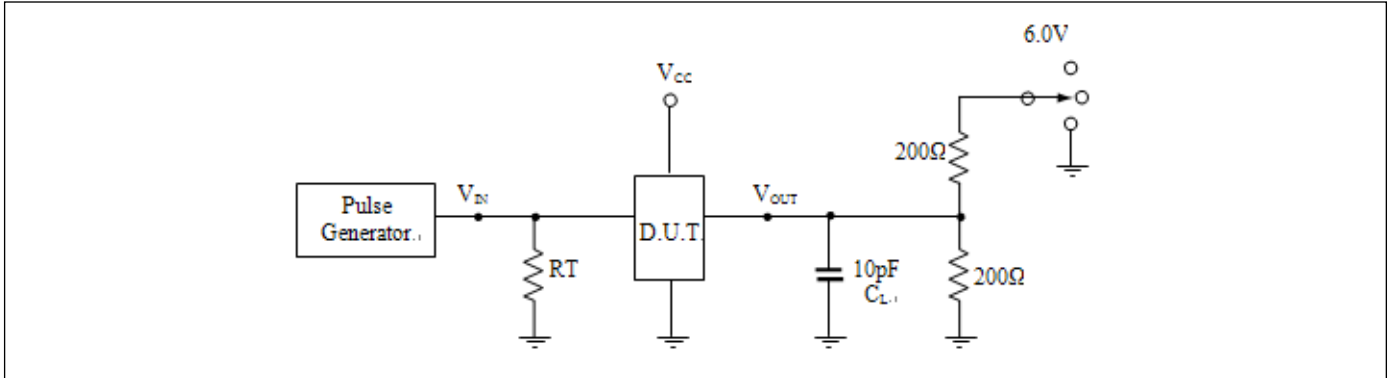

Notes:

1. C_L = Load capacitance: includes jig and probe capacitance.
2. R_T = Termination resistance: should be equal to Z_{OUT} of the pulse generator.
3. All input impulses are supplied by generators having the following characteristics: $PRR \leq 10$ MHz, $Z_O = 50\Omega$, $t_R \leq 2.5ns$, $t_F \leq 2.5ns$.
4. The outputs are measured one at a time with one transition per measurement.

Switch Positions

Test	Switch
t_{PLZ} , t_{PZL}	6.0V
t_{PHZ} , t_{PZH}	GND
Prop Delay	Open

Test Circuit for Dynamic Electrical Characteristics

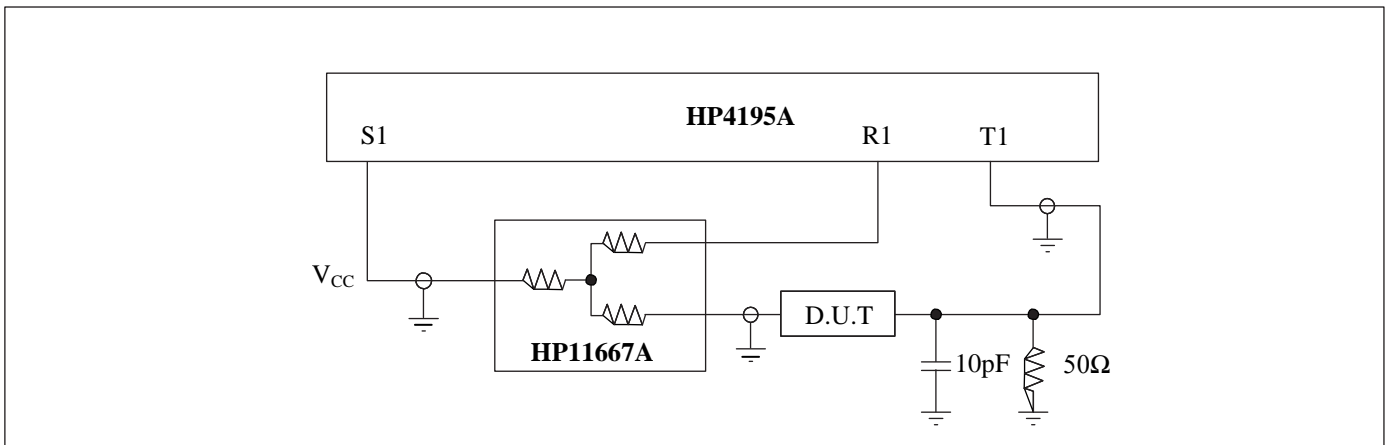

Switching Waveforms

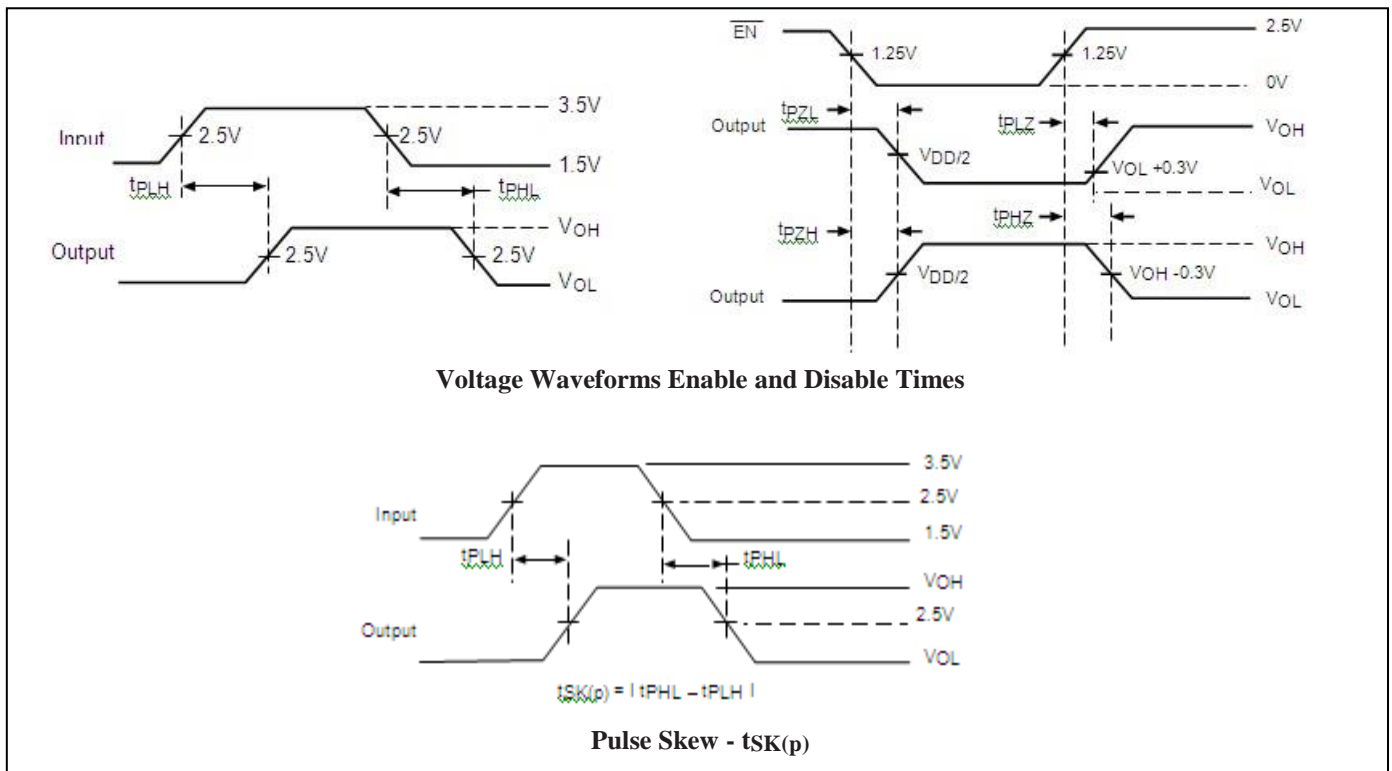

Applications Information

Logic Inputs

The logic control inputs can be driven up to 3.6V regardless of the supply voltage. For example given a +3.3V supply, \overline{EN} may be driven LOW to 0V and HIGH to 3.6V. Driving \overline{EN} Rail-to-Rail® minimizes power consumption.

Hot Insertion

For Datacom and Telecom applications that have ten or more volts passing through the backplane, a high voltage from the power supply can be seen at the device input pins during hot insertion. The PI3CH360 devices have maximum limits of 6V and 120mA for 20ns. If the power is higher, applied for a longer time, or repeatedly reaches the maximum limits, the devices can be damaged.

Part Marking

L Package



Z: Fixed Code
Y: Year
W: Workweek
1st X: Assembly Site Code
2nd X: Fab Site Code
Bar above "l" means Fab3 of MGN
Bar above fab code means Cu wire

Q Package



Z: Fixed Code
Y: Year
W: Workweek
1st X: Assembly Site Code
2nd X: Fab Site Code
Bar above fab code means Cu wire
Bar above "l" means Fab3 of MGN

ZHD Package

Top mark is not available at this time. To obtain advanced information regarding the top mark, please contact your local sales representative.

Rail-to-Rail is a registered trademark of Nippon Motorola, Ltd.

Mechanical Information

16-TSSOP (L)

SYMBOLS	MIN.	NOM.	MAX.
A	-	-	1.20
A1	0.05	-	0.15
A2	0.80	1.00	1.05
b	0.19	-	0.30
c	0.09	-	0.20
D	4.90	5.00	5.10
E1	4.30	4.40	4.50
E	6.20	6.40	6.60
e	0.65 BSC		
L1	1.00 REF		
L	0.45	0.60	0.75
S	0.20	-	-
θ	0°	-	8°

NOTES:
 1. ALL DIMENSIONS IN MILLIMETERS. ANGLES IN DEGREES.
 2. JEDEC MO-153F
 3. DIMENSIONS DOES NOT INCLUDE MOLD FLASH, PROTRUSIONS OR GATE BURRS.

		DATE: 03/24/16
DESCRIPTION: 16-Pin, 173mil Wide TSSOP		
PACKAGE CODE: L (L16)		
DOCUMENT CONTROL #: PD-1310	REVISION: G	

16-0061

16- QSOP (Q)

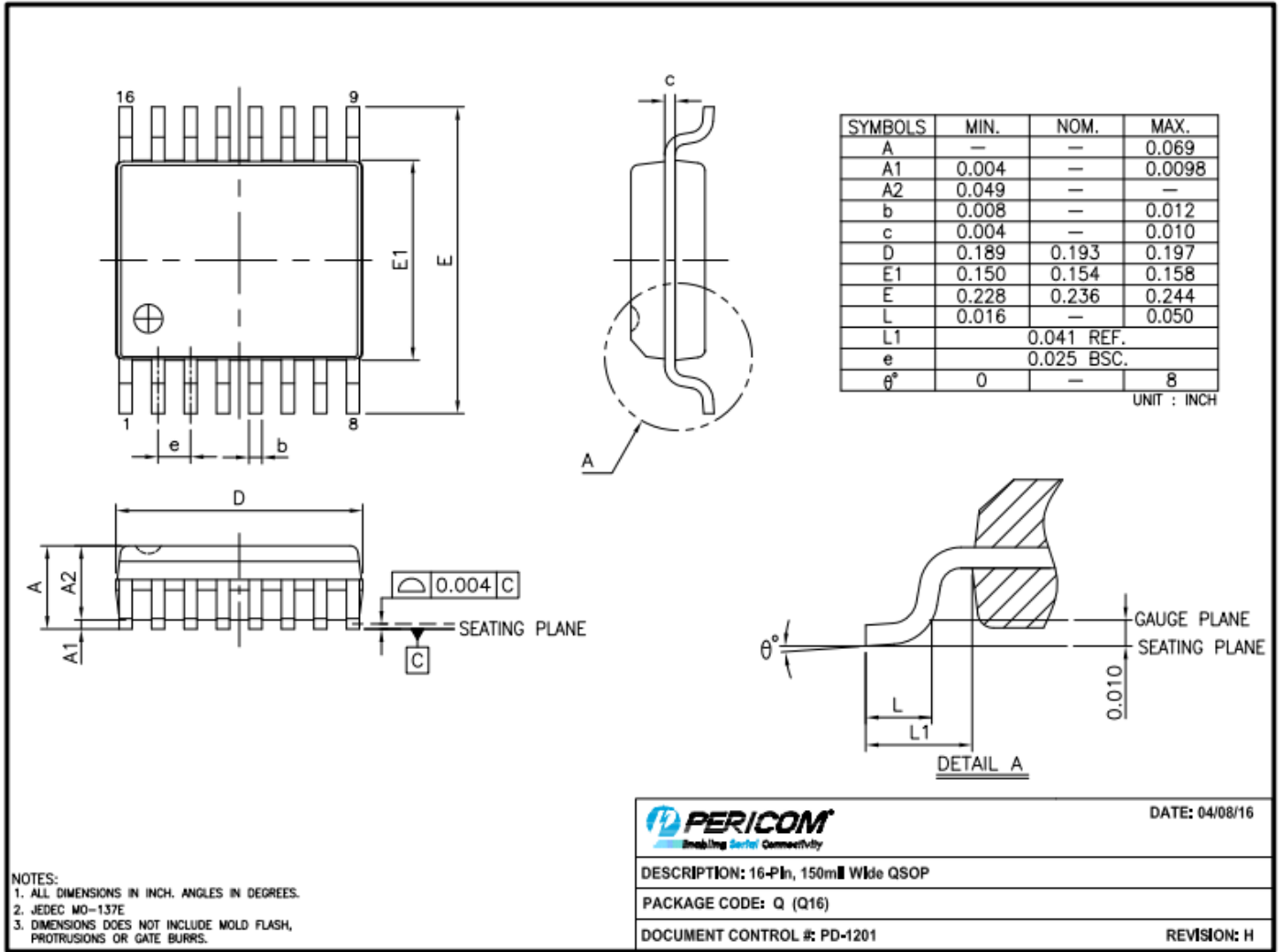

16-0056

16-UQFN (ZHD)

Top View

Bottom View

Side View

RECOMMENDED LAND PATTERN(unit:mm)

PKG. DIMENSIONS(MM)			
SYMBOL	Min	Nom	Max
A	0.55	0.60	0.65
A1	0.00	0.02	0.05
A3	0.15 REF		
D	2.90	3.00	3.10
E	2.90	3.00	3.10
D1	1.60	1.75	1.90
E1	1.60	1.75	1.90
b	0.18	0.24	0.30
e	0.50 BSC		
L	0.25	0.40	0.55

Note:
1. All DIMENSIONS ARE IN MILLIMETERS (ANGLES IN DEGREES).

				DATE: 04/22/20
DESCRIPTION: 16-Pin, UQFN, 3X3 (U-QFN3030-16)				
PACKAGE CODE: ZHD(ZHD16)				
DOCUMENT CONTROL#: PD-2209				REVISION: A

20-1248

For latest package information:

Please see <http://www.diodes.com/design/support/packaging/pericom-packaging/packaging-mechanicals-and-thermal-characteristics/>.

Ordering Information

Part Numbers	Package Code	Package Description
PI3CH480LEX	L	16-Pin, 173mil Wide (TSSOP)
PI3CH480QEX	Q	16-Pin, 150mil Wide (QSOP)
PI3CH480ZHDEX	ZHD	16-Pin, 3x3 (UQFN)

- Notes:
1. No purposely added lead. Fully EU Directive 2002/95/EC (RoHS), 2011/65/EU (RoHS 2) & 2015/863/EU (RoHS 3) compliant.
 2. See <https://www.diodes.com/quality/lead-free/> for more information about Diodes Incorporated's definitions of Halogen- and Antimony-free, "Green" and Lead free.
 3. Halogen- and Antimony-free "Green" products are defined as those which contain <900ppm bromine, <900ppm chlorine (<1500ppm total Br + Cl) and <1000ppm antimony compounds.
 4. E = Pb-free and Green
 5. X suffix = Tape/Reel