

**8-Bit Bus Switch, Enable Low 1.8V/2.5V/3.3V, High-Bandwidth, Hot Plug**

**Features**

- ➔ Near-Zero propagation delay
- ➔ 5-ohm switches connect inputs to outputs
- ➔ High signal passing bandwidth (500 MHz)
- ➔ Beyond Rail-to-Rail switching
  - 0 to 5V switching with 3.3V power supply
  - 0 to 3.3V switching with 2.5V power supply
- ➔ 5V I/O tolerant with supply in OFF and ON state
- ➔ 1.8V, 2.5V and 3.3V supply voltage operation
- ➔ Hot Insertion Capable
- ➔ Industrial Operating Temperature: -40°C to +85°C
- ➔ 8kV ESD Protection (human body model)
- ➔ Latch-up Performance: >200mA per JESD17
- ➔ Packaging (Pb-free & Green available):
  - 20-pin 150-mil wide plastic QSOP (Q)
  - 20-pin 173-mil wide plastic TSSOP (L)
  - 20-pin TQFN (ZH)

**Description**

The PI3CH800 is a low voltage, 8-channel switch designed with fast individual enables. The switch introduces no additional ground bounce noise or additional propagation delay.

The PI3CH800 device has active low enables. It is very useful in switching signals that have high bandwidth (500 MHz).

**Applications**

- ➔ High Bandwidth Data Switching
- ➔ Hot-Docking
- ➔ Analog Signal Switching
- ➔ Differential Signal Switching

**Pin Configuration**

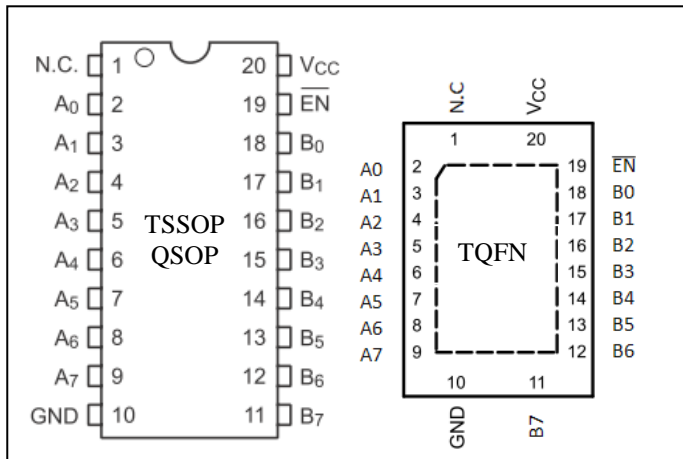

**Block Diagram**

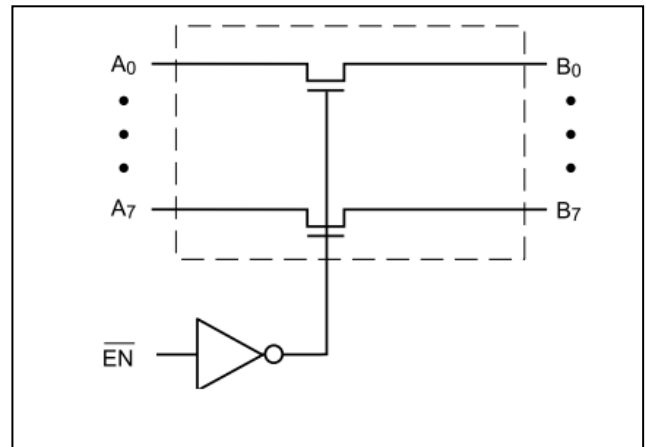

**Pin Description**

Pin No	Pin Name	Description
19	$\overline{EN}$	Switch Enables
2, 3, 4, 5, 6, 7, 8, 9	A0-A7	A Ports
10	GND	Ground
11, 12, 13, 14, 15, 16, 17, 18	B0-B7	B Ports
20	V <sub>CC</sub>	Power

**Truth Table<sup>(1)</sup>**

$\overline{EN}$	A <sub>x</sub>	Function
H	Hi-Z	Disconnect
L	B <sub>x</sub>	Connect

**Note:**

1. H=High Voltage Level; L=Low Voltage Level; Hi-Z=High Impedance

## Maximum Ratings

Storage Temperature.....	-65°C to +150°C
Ambient Temperature with Power Applied.....	-40°C to +85°C
Supply Voltage to Ground Potential.....	-0.5V to +4.6V
DC Input Voltage.....	-0.5V to +6.0V
DC Output Current.....	120mA
Power Dissipation.....	0.5W

### Note:

Stresses greater than those listed under MAXIMUM RATINGS may cause permanent damage to the device. This is a stress rating only and functional operation of the device at these or any other conditions above those indicated in the operational sections of this specification is not implied. Exposure to absolute maximum rating conditions for extended periods may affect reliability.

## DC Electrical Characteristics

3.3V supply (Over operating range,  $T_A = -40 \sim +85^\circ\text{C}$ ,  $V_{CC} = 3.3\text{V} \pm 10\%$ , unless otherwise noted)

Symbol	Description	Test Conditions <sup>(1)</sup>	Min	Typ <sup>(2)</sup>	Max	Unit
$V_{IH}$	Control Input HIGH Voltage	Guaranteed Logic HIGH Level	2.0	-	-	V
$V_{IL}$	Control Input LOW Voltage	Guaranteed Logic LOW Level	-0.5	-	0.8	V
$V_{IK}$	Clamp Diode Voltage	$V_{CC} = \text{Min.}, I_{IN} = -18\text{mA}$	-	-1.3	-1.8	V
$I_{IH}$	Input HIGH Current	$V_{CC} = \text{Max.}, V_{IN} = V_{CC}$	-	-	$\pm 1$	$\mu\text{A}$
$I_{IL}$	Input Low Current	$V_{CC} = \text{Max.}, V_{IN} = \text{GND}$	-	-	$\pm 1$	$\mu\text{A}$
$I_{OZH}$	High-Impedance Current	$0 \leq A, B \leq V_{CC}$	-	-	$\pm 1$	$\mu\text{A}$
$R_{ON}$	Switch On-Resistance <sup>(3)</sup>	$V_{CC} = \text{Min.}, V_{IN} = 0.0\text{V}$ $I_{ON} = -48\text{mA}$ or $-64\text{mA}$	-	4	6	$\Omega$
		$V_{CC} = \text{Min.}, V_{IN} = 3.6\text{V}$ $I_{ON} = -15\text{mA}$	-	5	8	

### Notes:

1. For Max. or Min. conditions, use appropriate value specified under Electrical Characteristics for the applicable device type.
2. Typical values are at  $V_{CC} = 3.3\text{V}$ ,  $T_A = 25^\circ\text{C}$  ambient and maximum loading.
3. Measured by the voltage drop between A and B pin at indicated current through the switch. On-Resistance is determined by the lower of the voltages on the two (Ax, Bx) pins.

2.5V supply (Over operating range,  $T_A = -40 \sim +85^\circ\text{C}$ ,  $V_{CC} = 2.5\text{V} \pm 10\%$ , unless otherwise noted)

Symbol	Description	Test Conditions <sup>(1)</sup>	Min	Typ <sup>(2)</sup>	Max	Unit
$V_{IH}$	Control Input HIGH Voltage	Guaranteed Logic HIGH Level	1.8	-	$V_{CC} + 0.3$	V
$V_{IL}$	Control Input LOW Voltage	Guaranteed Logic LOW Level	-0.3	-	0.8	V
$V_{IK}$	Clamp Diode Voltage	$V_{CC} = \text{Max.}, I_{IN} = -6\text{mA}$	-	-0.7	-1.8	V
$I_{IH}$	Input HIGH Current	$V_{CC} = \text{Max.}, V_{IN} = V_{CC}$	-	-	$\pm 1$	$\mu\text{A}$
$I_{IL}$	Input Low Current	$V_{CC} = \text{Max.}, V_{IN} = \text{GND}$	-	-	$\pm 1$	$\mu\text{A}$
$I_{OZH}$	High-Impedance Current	$0 \leq A, B \leq V_{CC}$	-	-	$\pm 1$	$\mu\text{A}$
$R_{ON}$	Switch On-Resistance <sup>(3)</sup>	$V_{CC} = \text{Min.}, V_{IN} = 0.0\text{V}$ $I_{ON} = -48\text{mA}$	-	4	8	$\Omega$
		$V_{CC} = \text{Min.}, V_{IN} = 2.25\text{V}$ $I_{ON} = -15\text{mA}$	-	7	14	

### Notes:

1. For Max. or Min. conditions, use appropriate value specified under Electrical Characteristics for the applicable device type.
2. Typical values are at  $V_{CC} = 2.5\text{V}$ ,  $T_A = 25^\circ\text{C}$  ambient and maximum loading.
3. Measured by the voltage drop between A and B pin at indicated current through the switch. On-Resistance is determined by the lower of the voltages on the two (Ax, Bx) pins.

1.8V supply (Over operating range,  $T_A = -40 \sim +85^\circ\text{C}$ ,  $V_{CC} = 1.8\text{V} \pm 10\%$ , unless otherwise noted)

Symbol	Description	Test Conditions <sup>(1)</sup>	Min	Typ <sup>(2)</sup>	Max	Unit
$V_{IH}$	Control Input HIGH Voltage	Guaranteed Logic HIGH Level	1.2	-	$V_{CC} + 0.3$	V
$V_{IL}$	Control Input LOW Voltage	Guaranteed Logic LOW Level	-0.3	-	0.6	V
$V_{IK}$	Clamp Diode Voltage	$V_{CC} = \text{Max.}$ , $I_{IN} = -6\text{mA}$	-	-0.7	-1.8	V
$I_{IH}$	Input HIGH Current	$V_{CC} = \text{Max.}$ , $V_{IN} = V_{CC}$	-	-	$\pm 1$	$\mu\text{A}$
$I_{IL}$	Input Low Current	$V_{CC} = \text{Max.}$ , $V_{IN} = \text{GND}$	-	-	$\pm 1$	$\mu\text{A}$
$I_{OZH}$	High-Impedance Current	$0 \leq A, B \leq V_{CC}$	-	-	$\pm 1$	$\mu\text{A}$
$R_{ON}$	Switch On-Resistance <sup>(3)</sup>	$V_{CC} = \text{Min.}$ , $V_{IN} = 0.0\text{V}$ $I_{ON} = -48\text{mA}$	-	4	8	$\Omega$
		$V_{CC} = \text{Min.}$ , $V_{IN} = 2.25\text{V}$ $I_{ON} = -15\text{mA}$	-	10	25	

**Notes:**

- For Max. or Min. conditions, use appropriate value specified under Electrical Characteristics for the applicable device type.
- Typical values are at  $V_{CC} = 1.8\text{V}$ ,  $T_A = 25^\circ\text{C}$  ambient and maximum loading.
- Measured by the voltage drop between A and B pin at indicated current through the switch. On-Resistance is determined by the lower of the voltages on the two (Ax, Bx) pins.

**Capacitance** ( $T_A = 25^\circ\text{C}$ ,  $f = 1\text{MHz}$ )

Symbol <sup>(1)</sup>	Description	Test Conditions	Typ <sup>(2)</sup>	Unit
$C_{IN}$	Input Capacitance	$V_{IN} = 0\text{V}$	2.0	pF
$C_{OFF}$	A/B Capacitance, Switch Off		3.5	
$C_{ON}$	A/B Capacitance, Switch On		7.0	

**Note:**

- These parameters are determined by device characterization but are not production tested

**Power Supply Characteristics**

Symbol	Description	Test Conditions <sup>(1)</sup>	Min	Typ	Max	Unit
$I_{CC}$	Quiescent Power Supply Current	$V_{CC} = 3.6\text{V}$ , $V_{IN} = \text{GND}$ or $V_{CC}$	-	0.2	0.5	mA

**Note:**

- For Max. or Min. conditions, use appropriate value specified under Electrical Characteristics for the applicable device.
- Typical values are at  $+25^\circ\text{C}$  ambient

**Dynamic Electrical Characteristics**

 (Over Operating Range,  $T_A = -40 \sim +85^\circ\text{C}$ ,  $V_{CC} = 3.3\text{V} \pm 10\%$ )

Symbol	Description	Test Conditions	Min	Typ	Max	Unit
$X_{TALK}$	Crosstalk	10MHz	-	-60	-	dB
$O_{IRR}$	Off-Isolation	10MHz	-	-60	-	
BW	-3dB Bandwidth	See test Diagram	-	500	-	MHz

## Switch Characteristics

Over 3.3V Operating Range

Symbol	Description	Test Conditions <sup>(1)</sup>	Min	Typ	Max	Unit
$t_{PLH}$ , $t_{PHL}$	Propagation Delay <sup>(2,3)</sup> Ax to Bx, Bx to Ax	See test Diagram	-	-	0.3	ns
$t_{PZH}$ , $t_{PZL}$	Enable Time $\overline{EN}$ to Ax or Bx	See test Diagram	1.5	-	9.0	
$t_{PHZ}$ , $t_{PLZ}$	Disable Time $\overline{EN}$ to Ax or Bx	See test Diagram	1.5	-	9.0	

**Note:**

1. See test circuit and waveforms.
2. This parameter is guaranteed but not tested on Propagation Delays.
3. The switch contributes no propagation delay other than the RC delay of the On-Resistance of the switch and the load capacitance. The time constant for the switch alone is of the order of 0.30ns for 10pF load. Since this time constant is much smaller than the rise/fall times of typical driving signals, it adds very little propagation delay to the system. Propagation delay of the switch when used in a system is determined by the driving circuit on the driving side of the switch and its interaction with the load on the driven side.

Over 2.5V Operating Range

Symbol	Description	Test Conditions <sup>(1)</sup>	Min	Typ	Max	Unit
$t_{PLH}$ , $t_{PHL}$	Propagation Delay <sup>(2,3)</sup> Ax to Bx, Bx to Ax	See test Diagram	-	-	0.3	ns
$t_{PZH}$ , $t_{PZL}$	Enable Time $\overline{EN}$ to Ax or Bx	See test Diagram	1.5	-	15.0	
$t_{PHZ}$ , $t_{PLZ}$	Disable Time $\overline{EN}$ to Ax or Bx	See test Diagram	1.5	-	12.0	

**Note:**

1. See test circuit and waveforms.
2. This parameter is guaranteed but not tested on Propagation Delays.
3. The switch contributes no propagation delay other than the RC delay of the On-Resistance of the switch and the load capacitance. The time constant for the switch alone is of the order of 0.30ns for 10pF load. Since this time constant is much smaller than the rise/fall times of typical driving signals, it adds very little propagation delay to the system. Propagation delay of the switch when used in a system is determined by the driving circuit on the driving side of the switch and its interaction with the load on the driven side.

Over 1.8V Operating Range

Symbol	Description	Test Conditions <sup>(1)</sup>	Min	Typ	Max	Unit
$t_{PLH}$ , $t_{PHL}$	Propagation Delay <sup>(2,3)</sup> Ax to Bx, Bx to Ax	See test Diagram	-	-	0.3	ns
$t_{PZH}$ , $t_{PZL}$	Enable Time EN to Ax or $\overline{Bx}$	See test Diagram	1.5	-	25.0	
$t_{PHZ}$ , $t_{PLZ}$	Disable Time EN to Ax or $\overline{Bx}$	See test Diagram	1.5	-	12.0	

**Note:**

1. See test circuit and waveforms.
2. This parameter is guaranteed but not tested on Propagation Delays.
3. The switch contributes no propagation delay other than the RC delay of the On-Resistance of the switch and the load capacitance. The time constant for the switch alone is of the order of 0.30ns for 10pF load. Since this time constant is much smaller than the rise/fall times of typical driving signals, it adds very little propagation delay to the system. Propagation delay of the switch when used in a system is determined by the driving circuit on the driving side of the switch and its interaction with the load on the driven side.

**Test Circuit for Electrical Characteristics**

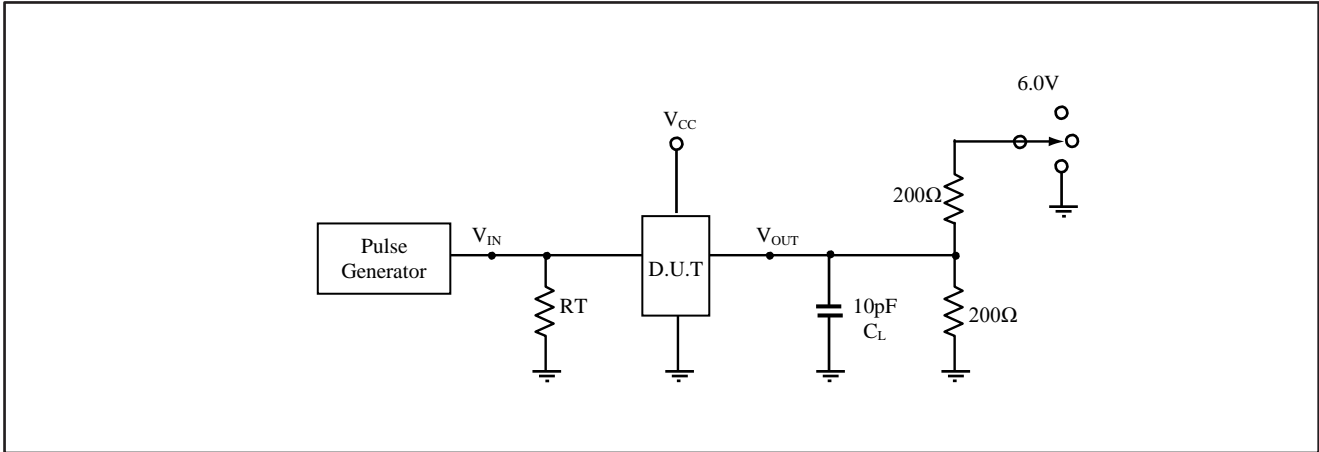

**Notes:**

1.  $C_L$  = Load capacitance: includes jig and probe capacitance.
2.  $R_T$  = Termination resistance: should be equal to  $Z_{OUT}$  of the Pulse Generator
3. All input impulses are supplied by generators having the following characteristics:  $PRR \leq 10$  MHz,  $Z_O = 50$ -ohm,  $t_R \leq 2.5$ ns,  $t_F \leq 2.5$ ns.
4. The outputs are measured one at a time with one transition per measurement.

**Switch Positions**

Te	Switch
$t_{PLZ}, t_{PZL}$	6.0V
$t_{PHZ}, t_{PZH}$	GND
Prop Delay	Open

**Test Circuit for Dynamic Electrical Characteristics**

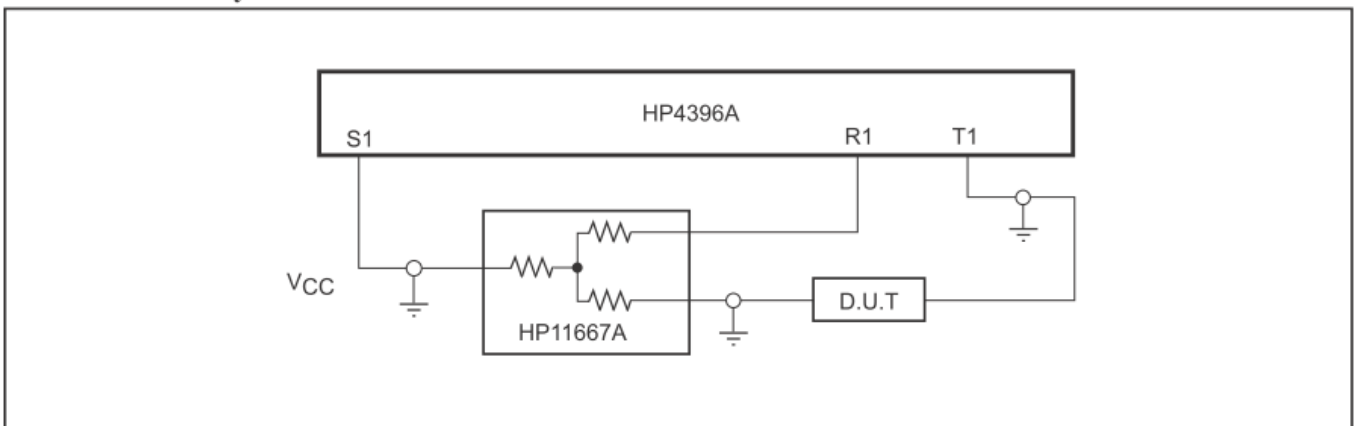

## Switching Waveforms

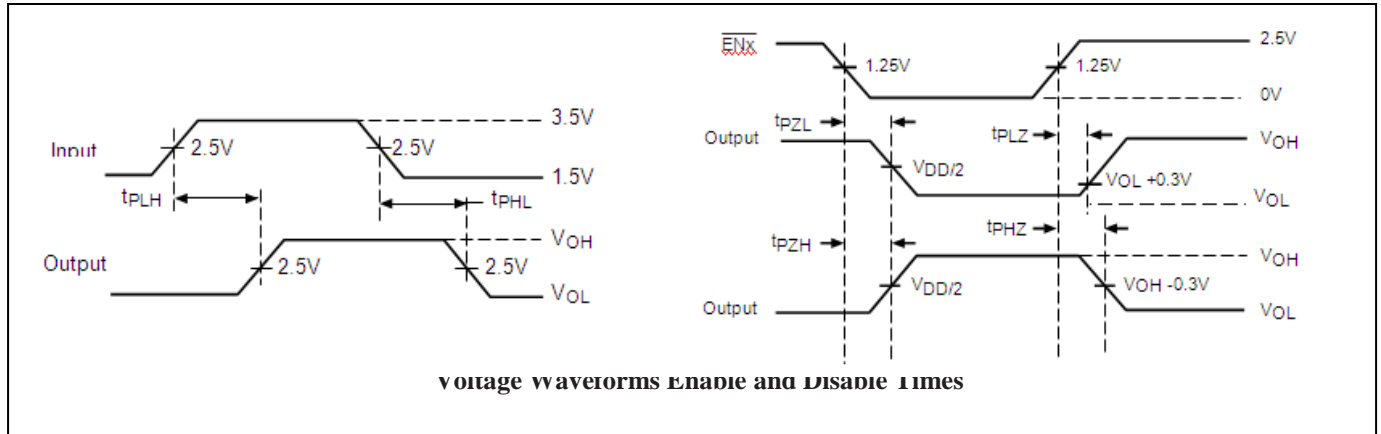

## Applications Information

### Logic Inputs

The logic control inputs can be driven up to 3.6V regardless of the supply voltage. For example, given a +3.3V supply,  $\overline{EN}$  may be driven LOW to 0V and HIGH to 3.6V. Driving  $\overline{EN}$  Rail-to-Rail<sup>®</sup> minimizes power consumption.

### Hot Insertion

For Datacom and Telecom applications that have ten or more volts passing through the backplane, a high voltage from the power supply may be seen at the device input pins during hot insertion. The PI3CH400 devices have maximum limits of 6V and 120mA for 20ns. If the power is higher or applied for a longer time or repeatedly reaches the maximum limits, the devices can be damaged.

*Rail-to-Rail is a registered trademark of Nippon Motorola, Ltd.*

## Part Marking

### L Package

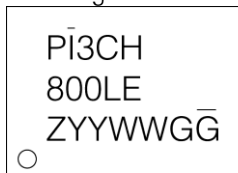

Z: Fixed Code  
YY: Year  
WW: Workweek  
First G: Assembly Site Code  
Last G: Wafer Fab Site Code

### ZH Package

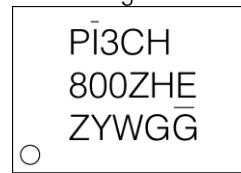

Z: Fixed Code  
Y: Year  
W: Workweek  
First G: Assembly Site Code  
Last G: Wafer Fab Site Code

### Q Package

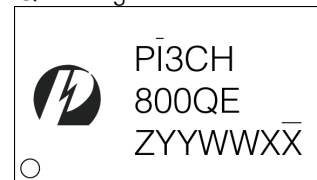

Z: Fixed Code  
YY: Year  
WW: Workweek  
1st X: Assembly Site Code  
2nd X: Fab Site Code

**Packaging Mechanical**

20-TSSOP(L)

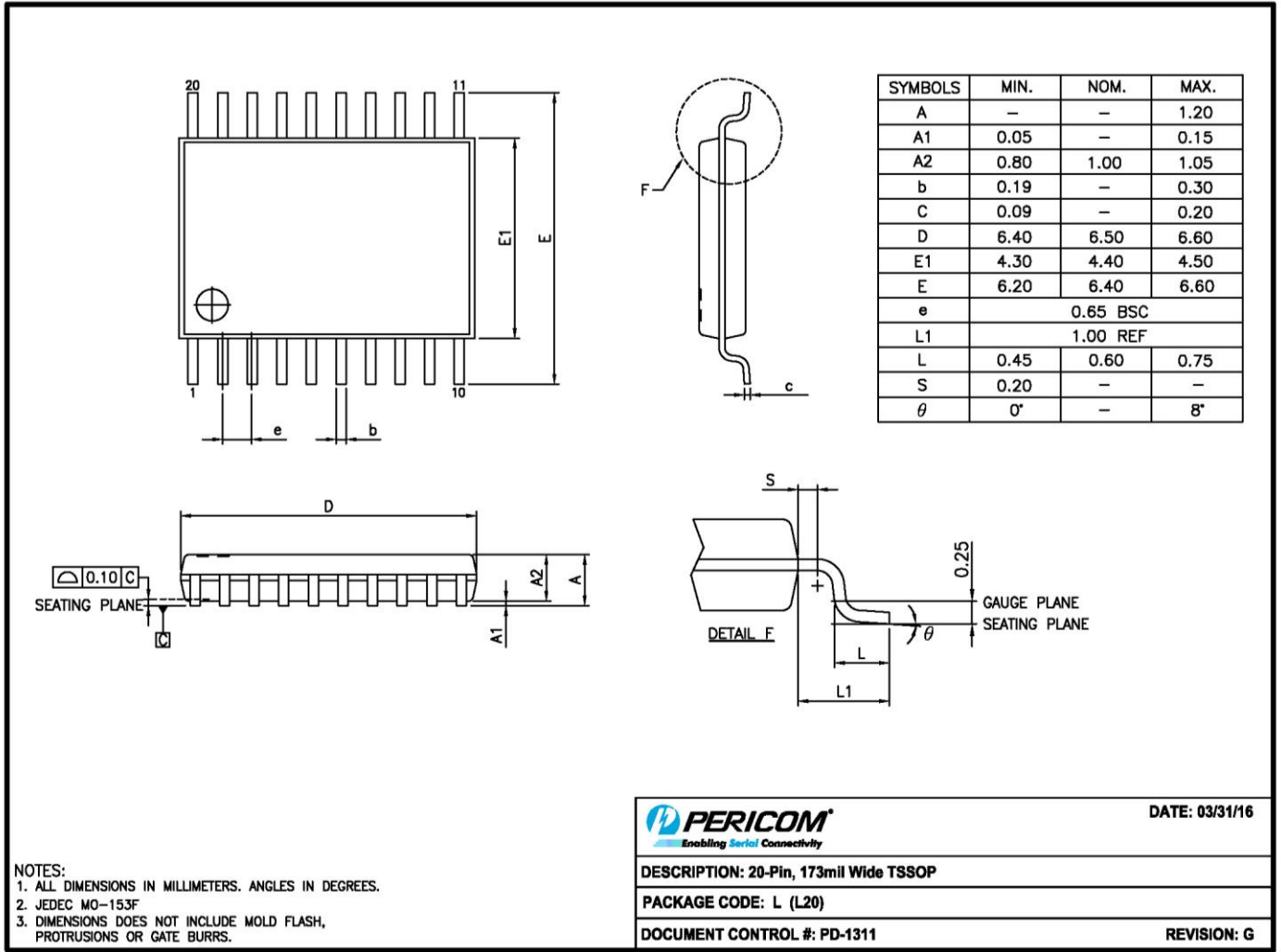

16-0074

20-TQFN(ZH)

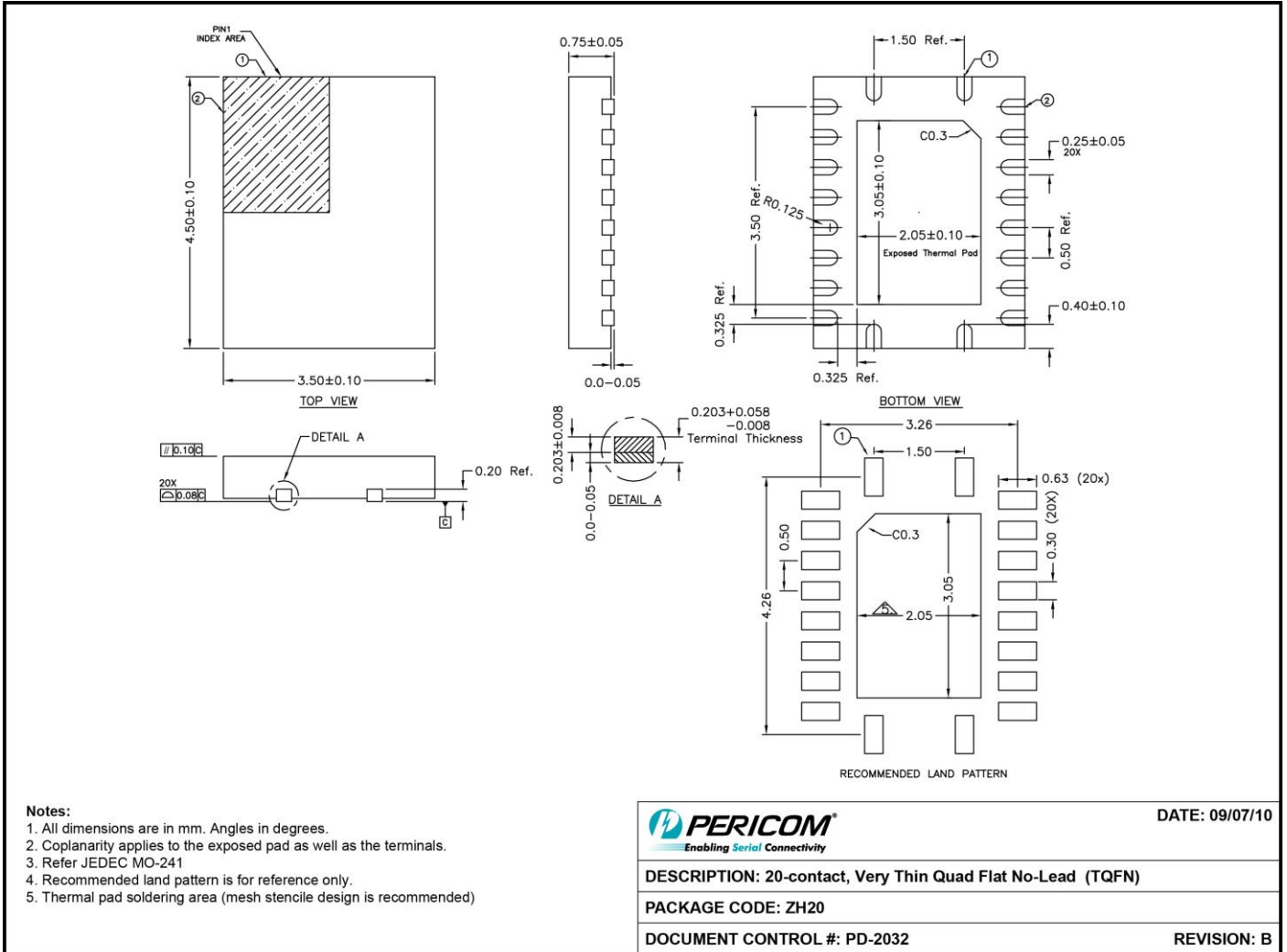

**Notes:**

1. All dimensions are in mm. Angles in degrees.
2. Coplanarity applies to the exposed pad as well as the terminals.
3. Refer JEDEC MO-241
4. Recommended land pattern is for reference only.
5. Thermal pad soldering area (mesh stencil design is recommended)

 <small>Enabling Serial Connectivity</small>	DATE: 09/07/10
DESCRIPTION: 20-contact, Very Thin Quad Flat No-Lead (TQFN)	
PACKAGE CODE: ZH20	
DOCUMENT CONTROL #: PD-2032	REVISION: B



20-QSOP(Q)

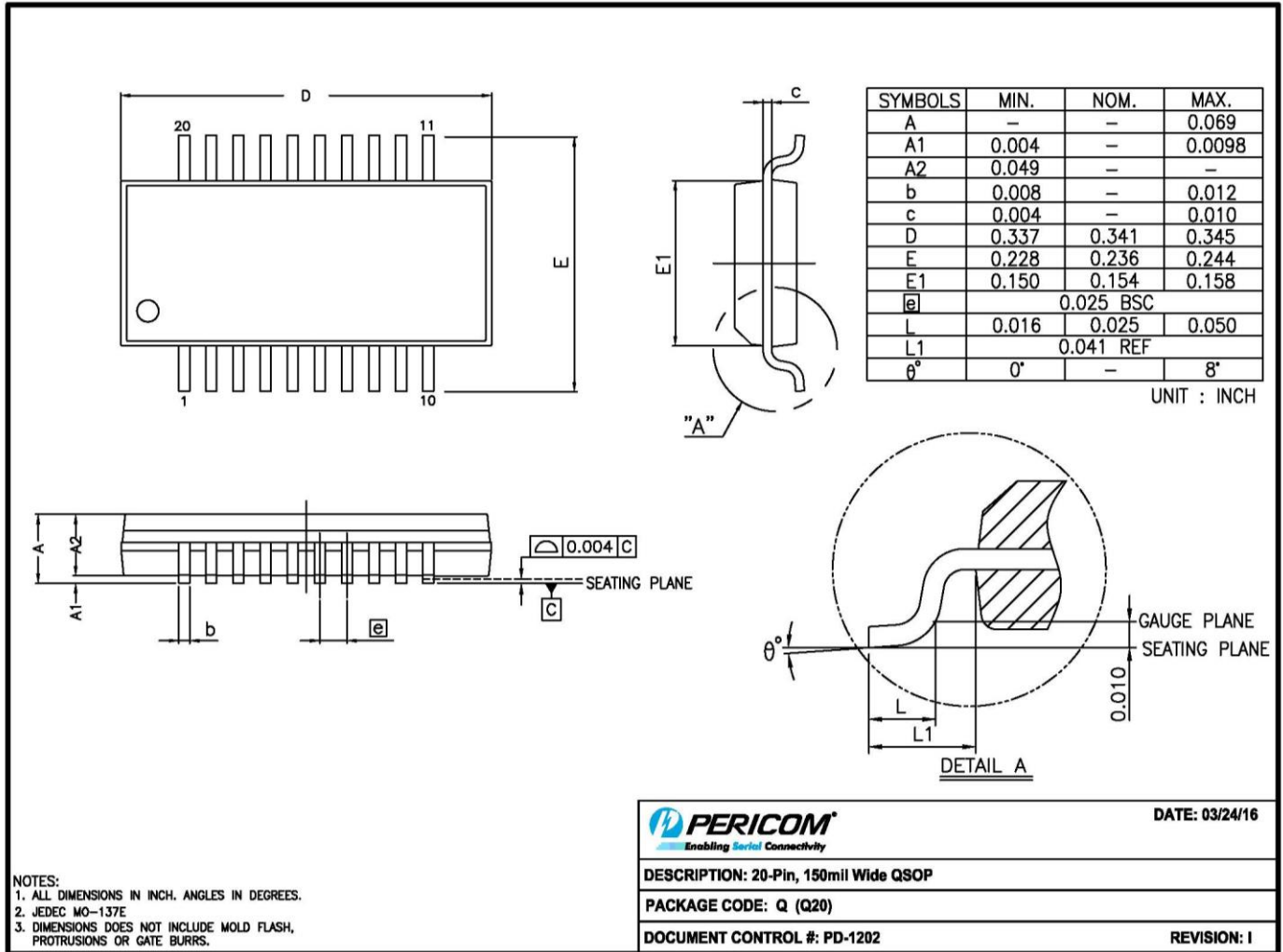

16-0057

For latest package info.

please check: <http://www.diodes.com/design/support/packaging/pericom-packaging/packaging-mechanicals-and-thermal-characteristics/>

## Ordering Information

Part Number	Package Code	Package Description
PI3CH800LEX	L	20-Pin, 173mil-Wide (TSSOP)
PI3CH800ZHEX	ZH	20-Pin, Very Thin Quad Flat No-Lead (TQFN)
PI3CH800QEX	Q	20-Pin, 150mil-Wide (QSOP)

### Notes:

- EU Directive 2002/95/EC (RoHS), 2011/65/EU (RoHS 2) & 2015/863/EU (RoHS 3) compliant. All applicable RoHS exemptions applied.
- See <http://www.diodes.com/quality/lead-free/> for more information about Diodes Incorporated's definitions of Halogen- and Antimony-free, "Green" and Lead-free.
- Thermal characteristics can be found on the company web site at [www.diodes.com/design/support/packaging/](http://www.diodes.com/design/support/packaging/)
- E = Pb-free and Green
- X suffix = Tape/Reel