

PI3HDX1204E

HDMI 2.0 6Gbps Linear ReDriver with High EQ, Low Jitter and DP++ Level Shifter

Description

PI3HDX1204E is the HDMI 2.0 Linear Redriver with the Level Shifter, supporting the minimum additive jitters. The linear Redriver provides the easiness of handling the signal integrity issues known in the component placement and the setting parameters of Equalization and Flat Gain compensation between Source-side and Sink-side link system.

The advantage of Linear Redriver does not block the original source differential signals to maximize the Sink-side Receiver Digital Feedback Equalization (DFE) Feedback circuits to improve the high-speed linked signal quality. The output swing range can set by Swing control for the power saving.

The optimization of the signal quality over a variety of physical mediums by reducing Inter-symbol Interference (ISI) jitters can be done by the pin-strapping or I2C programming.

In EEPROM mode, the Equalization, Voltage Swing and Gain controls can be automatically loaded during the system power-up to eliminate the need of external microprocessor or software driver.

Features

- HDMI 2.0 Compliant TMDs Linear Redriver with 2x Improved Jitter Performance than conventional technology
- DP++ Level Shifting for HDMI output
- Linear Redriver increases TMDs Link Margin supporting Sink-side DFE (Decision Feedback Equalizers) receiver
- Every Channel's Equalizations, Swings and Gains are programmable Independently
- Support Pin- strap and I2C Programming
- Flexible 4-bit I2C address selectable (42-pin, ZH package)
- Power supply: 3.3V
- Totally Lead-Free & Fully RoHS Compliant (Notes 1 & 2)
- Halogen and Antimony Free. "Green" Device (Note 3)
- For automotive applications requiring specific change control (i.e. parts qualified to AEC-Q100/101/200, PPAP capable, and manufactured in IATF 16949 certified facilities), please [contact us](#) or your local Diodes representative.
<https://www.diodes.com/quality/product-definitions/>
- Package (Pb-Free & Green):
 - ◆ 32-pin TQFN (3x6mm)
 - ◆ 42-pin TQFN (3.5x9mm)

Applications

- TVs and Monitors near to the Sink-side Devices

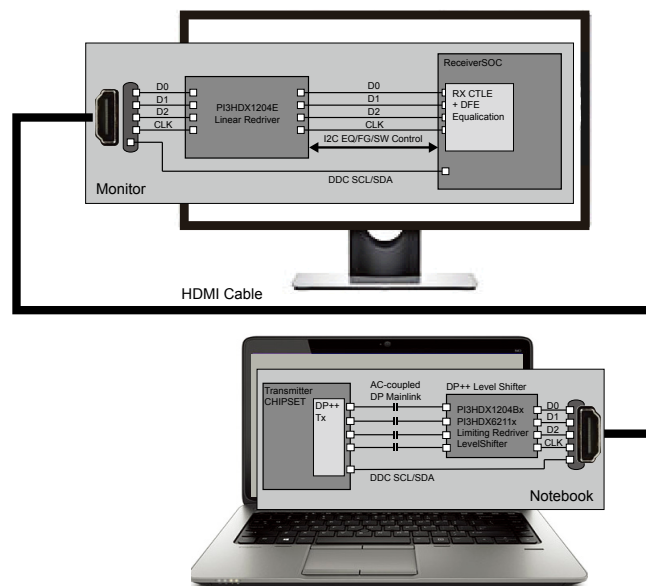

Figure 1-1 Monitor for sink-side with Rx DFE receiver

Ordering Information

Ordering Number	Package Code	Package Description
PI3HDX1204EZLEX	ZL	32-Contact, Very Thin Quad Flat No-Lead (TQFN)
PI3HDX1204EZHEX	ZH	42-Contact, Very Thin Quad Flat No-Lead (TQFN)

Notes:

1. No purposely added lead. Fully EU Directive 2002/95/EC (RoHS), 2011/65/EU (RoHS 2) & 2015/863/EU (RoHS 3) compliant.
2. See <https://www.diodes.com/quality/lead-free/> for more information about Diodes Incorporated's definitions of Halogen- and Antimony-free, "Green" and Lead-free.
3. Halogen- and Antimony-free "Green" products are defined as those which contain <900ppm bromine, <900ppm chlorine (<1500ppm total Br + Cl) and <1000ppm antimony compounds.
4. E = Pb-free and Green, I=Industrial
5. X suffix = Tape/Reel

2. General Information

2.1 Revision History

Date	Revision	Description
Mar 2016	-	Pin-out (p8): FGx(x=0,1) Pin name typo fixed.
Apr 2016	-	Electrical(p17): tSK_INTRA_OUT changed 5 typ, 10 max ps
May 2016	-	Application(p30): More informative system EE contents added. DDC source-side pull-up changed to 10 kΩ from 2 kΩ
Jun 2016	-	Mechanical (p39): EPAD outline changed
Oct 2016	-	Diodes Disclaimer added
Aug 2017	-	Clarified Output Swing range control in functional description. PI3HDX1204B1 limiting and PI3HDX1204E linear pin-out comparison added in generic information session
Dec 2017	1	Updated package mechanical drawing with latest (p46). Change to whole Revision number
Dec 2020	2	Updated Part Marking Updated Part Numbers Information Updated Pin Configuration Updated Pin Description Updated Features

2.2 PI3HDX1204D to PI3HDX1204E PDN Notice

PI3HDX1204E is a production part number of PI3HDX1204D. The detail comparison is summarized below.

	PI3HDX1204E	PI3HDX1204D
Changes	32-pin TQFN package added	EOL (End of Life). PI3HDX1204D was engineering version of PI3HDX1204E
Pin-out	No change	
Function control	No change	
Application Note	PI3HDX1204D application note and schematics are applicable to the PI3HDX1204E	

2.3 Similar Products Comparison

	PI3HDX1204B1	PI3HDX1204E
Redriver Type	Limiting type	Linear type
EQ at 6Gbps	22 dB	10 dB
Output TMDS peak-to-peak Swing	Output Swing Amplitude / Pre-Emphasis control. Blocking type	Follow Source Swing Amplitude. Non-blocking type.
DDC Switch/Buffer	No	No
HDMI1.4/2.0 Type ID	No	No
Ioff Protection	External Power Switch	External Power Switch
Data Rate (Gbps)	6 Gbps	6 Gbps
Application	Near to Source-side device	Near to Sink-side device
Availability	Production	Production

PI3HDX1204E

PI3HDX1204B1 / PI3HDX1204E Pin out Co-layout Comparison	Connection Description
<p>EQ3/AD3 EQ2/AD2 EQ1/AD1 EQ0/AD0</p> <p>BST3 BST2 BST1 BST0</p> <p>42 41 40 39</p> <p>SW1 DE1 1 38 PS1 FG1/I2C_RESET# SW0 DE0 2 37 PS0 FG0 VCC 3 36 VCC A0RX+ 4 35 A0TX+ A0RX- 5 34 A0TX- GND 6 33 VCC A1RX+ 7 32 A1TX+ A1RX- 8 31 A1TX- VCC 9 30 VCC A2RX+ 10 29 A2TX+ A2RX- 11 28 A2TX- GND 12 27 VCC A3RX+ 13 26 A3TX+ A3RX- 14 25 A3TX- VCC 15 24 VCC DNC A1 16 23 VOD1 DNC DNC A4 17 22 A0 NC</p> <p>18 19 20 21</p> <p>SDA SCL PEN PIN_MODE</p> <p>PI3HDX1204B1</p> <p>PI3HDX1204E</p> <p>PRSNT# ENI2C</p>	<p>Pin 16,17,23: Do not connect in PI3HDX1204E Pin 1,2,20,21,22,37,38,39,40,41,42: Pull-up and Pulldown pin mode control pins</p>

Contents

- 2. General Information** 2
 - 2.1 Revision History 2
 - 2.2 PI3HDX1204D to PI3HDX1204E PDN Notice..... 2
 - 2.3 Similar Products Comparison 2
- 3. Pin Configuration** 5
 - 3.1 Pin Configuration..... 5
 - 3.1 Pin Description 6
- 4. Functional Description** 10
 - 4.1 Functional Block..... 10
 - 4.2 Function Description 11
- 5. I2C Programming** 15
 - 5.1 Programming Registers 15
 - 5.2 I²C Operation 17
- 6. Electrical Specification** 19
 - 6.1 Absolute Maximum Ratings 19
 - 6.2 Recommended Operation Conditions 19
 - 6.3 Electrical Characteristics..... 19
 - 6.4 I2C Bus 24
- 7. Applications** 26
 - 7.1 DC/AC-coupled Application 26
 - 7.2 Sink-side Redriver Application..... 27
 - 7.3 Channels/Polarity Swap 27
 - 7.4 Output Eye Diagram..... 28
 - 7.5 Layout Guideline 32
 - 7.6 HDMI 2.0 Compliance Test..... 38
- 8. Mechanical/Packaging Information** 41
 - 8.1 Mechanical 41
 - 8.2 Part Marking Information 43
 - 8.3 Tape & Reel Materials and Design..... 44
- 9. Important Notice** 47

3. Pin Configuration

3.1 Pin Configuration

SW[1:0] = 11
(Tied high internally)

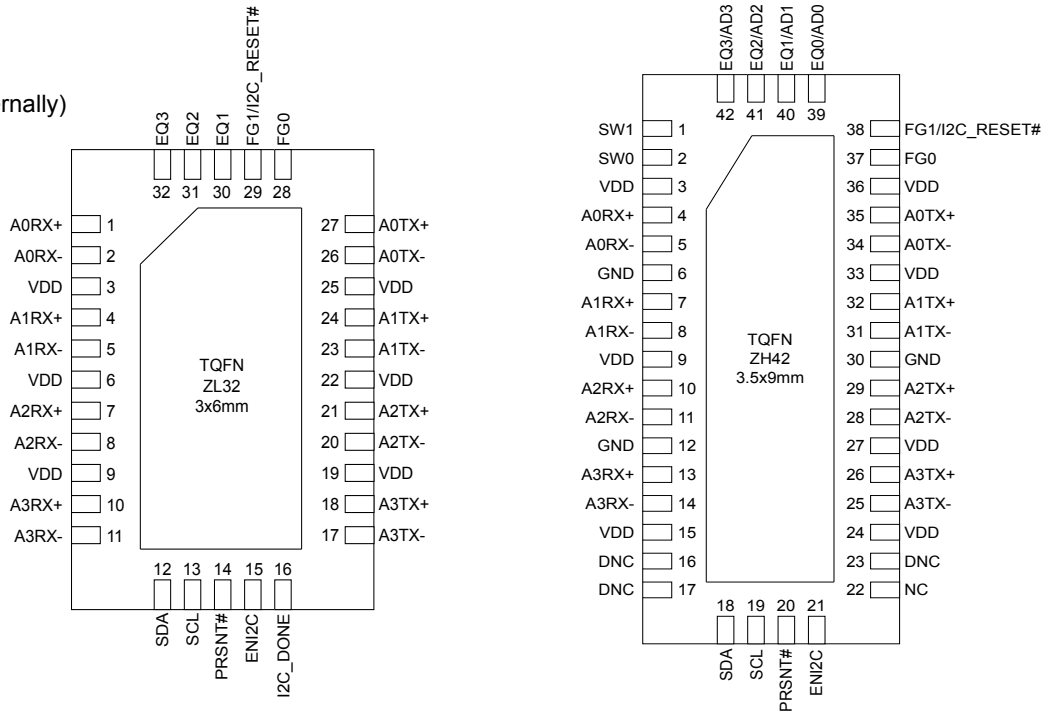

Figure 3-1 32/42-pin package pin-out

Note: In TMDs Data and Clock Differential Pairs of Input and Output, the polarity (+/- or P/N) of each pairs and high-speed data channels A[3:0] can use interchangeably. Output pins of polarity and data channel will always follow the input polarity and data channel assignment changes.

3.1 Pin Description

3.1.1 32-ZL Pin Package

Pin #	Pin Name	Type	Description
Data Signals			
1, 2	A0RX+ A0RX-	I	TMDS differential positive/negative input for Channel A0, with internal 50Ω Pull-Up and ~200kΩ Pull-Up otherwise.
27, 26	A0TX+ A0TX-	O	TMDS differential positive/negative outputs for Channel A0, with internal 50Ω Pull-Up and ~2kΩ Pull-Up otherwise.
4, 5	A1RX+ A1RX-	I	TMDS differential positive/negative inputs for Channel A1, with internal 50Ω Pull-Up and ~200kΩ Pull-Up otherwise.
24, 23	A1TX+ A1TX-	O	TMDS differential positive/negative outputs for Channel A1, with internal 50Ω Pull-Up and ~2kΩ Pull-Up otherwise.
7, 8	A2RX+ A2RX-	I	TMDS differential positive/negative inputs for Channel A2, with internal 50Ω Pull-Up and ~200kΩ Pull-Up otherwise.
21, 20	A2TX+ A2TX-	O	TMDS differential positive/negative outputs for Channel A2, with internal 50Ω Pull-Up and ~2kΩ Pull-Up otherwise.
10, 11	A3RX+ A3RX-	I	TMDS differential positive/negative inputs for Channel A3, with internal 50Ω Pull-Up and ~200kΩ Pull-Up otherwise.
18, 17	A3TX+ A3TX-	O	TMDS differential positive/negative outputs for Channel A3, with internal 50Ω Pull-Up and ~2kΩ Pull-Up otherwise.
Control Signals			
13	SCL	I/P	I ² C Serial Clock line
12	SDA	I/O	I ² C Serial Data line
14	PRSENT#	I	Cable Present Detect input. This pin has internal 100kΩ pull-up. The pin is active when both PIN mode (ENI2C = LOW) and I2C mode (ENI2C = HIGH). When High, a cable is not present, and the device is put in lower power mode. When Low, the device is enabled and in normal operation.
15	ENI2C	I	I2C Enable pin. When LOW, each channel is programmed by the external pin voltage. When HIGH, each channel is programmed by the data stored in the I2C bus.
32, 31, 30	EQ[3:1]	I	EQ Control pin. Inputs with internal 100kΩ pull-up. This pins set the amount of Equalizer Boost in all channels when ENI2C is low.
	AD[3:1]	I	Address bits control pins for I2C programming with internal 100kΩ pullup.
29	FG1/I2C_ RESET#	I	Shared pin for Gain Control bit-1 and I2C Reset pin. Inputs with internal 100kΩ pullup resistor. (1) Sets the output flat gain level bit-1 on all channels when ENI2C is Low. (2) I2C Reset pin. Active Low to reset the registers to default state.
28	FG0	I	Flat Gain control bit-0 pin. Inputs with internal 100kΩ pull up resistor. Sets the output flat gain level on all channels when ENI2C is low.

PI3HDX1204E

Pin #	Pin Name	Type	Description
16	I2C_DONE	O	I2C Done pin. Valid register load status output for using the daisy chain I2C master. Low = External EEPROM load failed High = External EEPROM load passed
Power Pins			
3, 6, 9, 19, 22, 25	VDD	PWR	3.3V Power supply pins
Center Pad	GND	GND	Exposed Ground pad.

3.1.2 42-ZH Pin Package

Pin #	Pin Name	Type	Description
Data Signals			
4, 5	A0RX+ A0RX-	I	TMDS differential positive/negative input for Channel A0, with internal 50Ω Pull-Up and ~200kΩ Pull-Up otherwise.
35, 34	A0TX+ A0TX-	O	TMDS differential positive/negative outputs for Channel A0, with internal 50Ω Pull-Up and ~2kΩ Pull-Up otherwise.
7, 8	A1RX+ A1RX-	I	TMDS differential positive/negative inputs for Channel A1, with internal 50Ω Pull-Up and ~200kΩ Pull-Up otherwise.
32, 31	A1TX+ A1TX-	O	TMDS differential positive/negative outputs for Channel A1, with internal 50Ω Pull-Up and ~2kΩ Pull-Up otherwise.
10, 11	A2RX+ A2RX-	I	TMDS differential positive/negative inputs for Channel A2, with internal 50Ω Pull-Up and ~200kΩ Pull-Up otherwise.
29, 28	A2TX+ A2TX-	O	TMDS differential positive/negative outputs for Channel A2, with internal 50Ω Pull-Up and ~2kΩ Pull-Up otherwise.
13, 14	A3RX+ A3RX-	I	TMDS differential positive/negative inputs for Channel A3, with internal 50Ω Pull-Up and ~200kΩ Pull-Up otherwise.
26, 25	A3TX+ A3TX-	O	TMDS differential positive/negative outputs for Channel A3, with internal 50Ω Pull-Up and ~2kΩ Pull-Up otherwise.
Control Signals			
16, 17, 23	DNC		Do Not Connect
19	SCL	I/O	I ² C Serial Clock line In Master mode (ENI2C pin floating), SCL is an output. Otherwise it is an input as a slave mode.
18	SDA	I/O	I ² C Serial Data line
20	PRSNT#	I	Cable Present Detect input. This pin has internal 100kΩ pull-up. The pin is active when both PIN mode (ENI2C = LOW) and I2C mode (ENI2C = HIGH). When High, a cable is not present, and the device is put in lower power mode. When Low, the device is enabled and in normal operation.
21	ENI2C	I	I2C Enable pin. When LOW, each channel is programmed by the external pin voltage. When HIGH, each channel is programmed by the data stored in the I2C bus. When floating, master mode (Read External EEPROM)
39, 40, 41, 42	EQ[3:1]	I	EQ Control pin. Inputs with internal 100kΩ pull-up. This pins set the amount of Equalizer Boost in all channels when ENI2C is low.
	AD[3:1]	I	Address bits control pins for I2C programming with internal 100kΩ pullup.
1, 2	SW[1:0]	I	Output Swing control pins. Inputs with internal 100kΩ pull-up. This pin sets the output Voltage Level in all channel when ENI2C is LOW.
38	FG1/I2C_ RESET#	I	Shared pin for Gain Control bit-1 and I2C Reset pin. Inputs with internal 100kΩ pullup resistor. (1) Sets the output flat gain level bit-1 on all channels when ENI2C is Low. (2) I2C Reset pin. Active Low to reset the registers to default state.

PI3HDX1204E

Pin #	Pin Name	Type	Description
37	FG0	I	Flat Gain control bit-0 pin. Inputs with internal 100kΩ pull up resistor. Sets the output flat gain level on all channels when ENI2C is low.
22	NC	NC	No Connect
Power Pins			
3, 9, 15, 24, 27, 33, 36	VDD	PWR	3.3V Power supply pins
6, 12, 30, Center Pad	GND	GND	Exposed Ground pad.

4. Functional Description

4.1 Functional Block

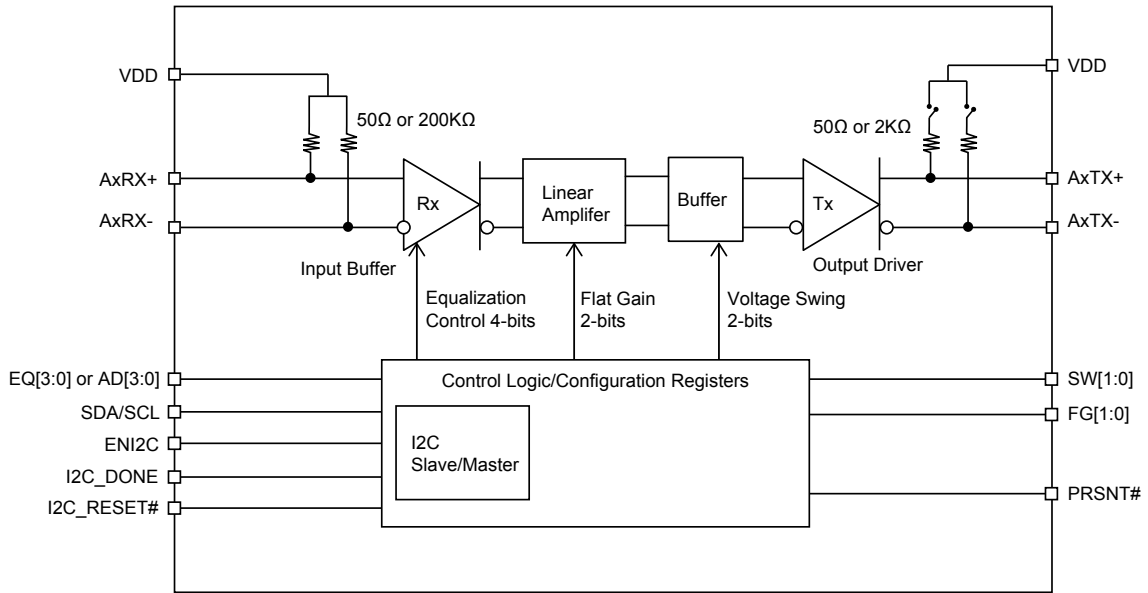

Figure 4-1 Functional Block Diagram

4.2 Function Description

4.2.1 Power-Down/Enable

When PRSNT# is set to "1", device enter to the power-down mode. When Input 200kΩ and Output High Impedance (HIZ) termination resistors set, each individual channels Ax(x=0,1,2,3) can program the I2C register.

4.2.2 Input Equalization Setting

The EQx(x=0,1,2,3) pins are the pin-strap option for each Ax(x=0,1,2,3) channels. It can also be programmable by the I2C mode.

Table 4-1. Equalization Setting for 42-pin

EQ3	EQ2	EQ1	EQ0	6Gbps Input (dB)
0	0	0	0	3.6
0	0	0	1	4.0
0	0	1	0	4.4
0	0	1	1	4.7
0	1	0	0	5.1
0	1	0	1	5.5
0	1	1	0	5.9
0	1	1	1	6.2
1	0	0	0	6.6
1	0	0	1	6.9
1	0	1	0	7.3
1	0	1	1	7.6
1	1	0	0	8.0
1	1	0	1	8.2
1	1	1	0	8.6
1	1	1	1	8.9

Table 4-2. Equalization Setting for 32-pin

EQ3	EQ2	EQ1	6Gbps Input (dB)	Notes
0	0	0	4.0	(1) EQ0 pin always tied to "1" internally in 32-pin package.
0	0	1	4.7	
0	1	0	5.5	
0	1	1	6.2	
1	0	0	6.9	
1	0	1	7.6	
1	1	0	8.2	
1	1	1	8.9	

4.2.3 Output -1 dB Compression Swing setting

SW_x(x=0,1) affects the linearity of the output when input amplitude changes.

Table 4-3. SW[1:0] Output Swing Setting

SW1	SW0	Voltage Swing mVpp @100MHz	Voltage Swing mVpp @ 6Gbps	Notes
0	0	920	1100	
0	1	1040	1200	
1	0	1280	1300	
1	1	1370	1400	Default Setting. Internally 100kΩ pull-up.

Note: (1) SW[1:0]=11 setting support by I2C programming in 32-pin package

4.2.4 Flat Gain Setting

FG_x(x=0,1) two pins are the selection 2 bits for the DC Flat Gain value.

Table 4-4. Flat Gain FG[1:0] Control

FG1	FG0	Gain (dB)
0	0	-3.5
0	1	-1.5
1	0	+0.5
1	1	+2.5

PI3HDX1204E

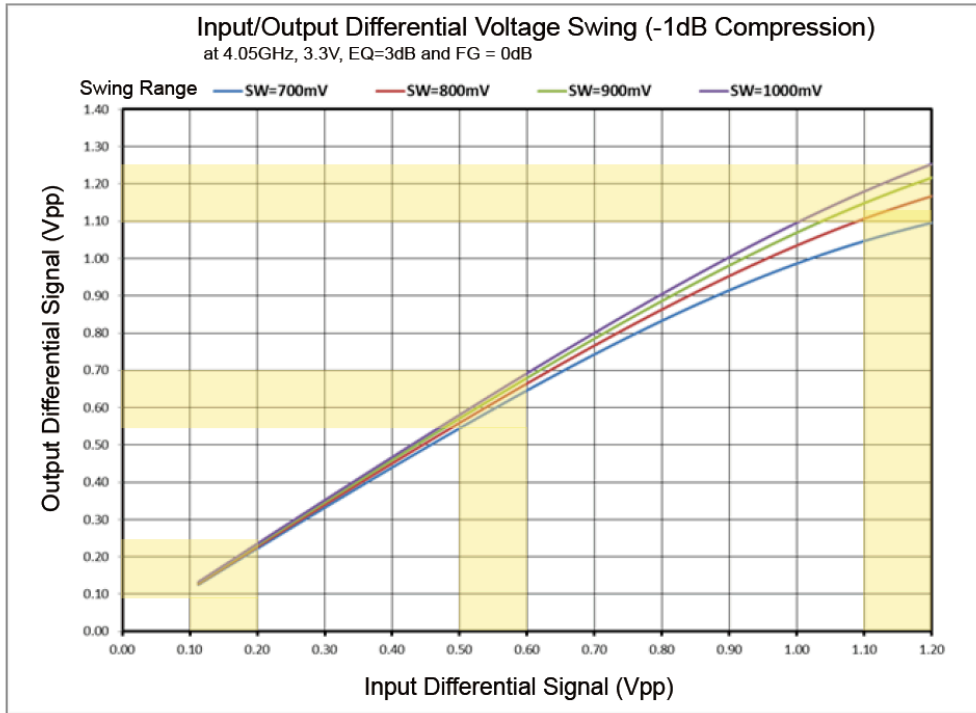

Figure 4-2 Example of Output voltage swing with different SW setting

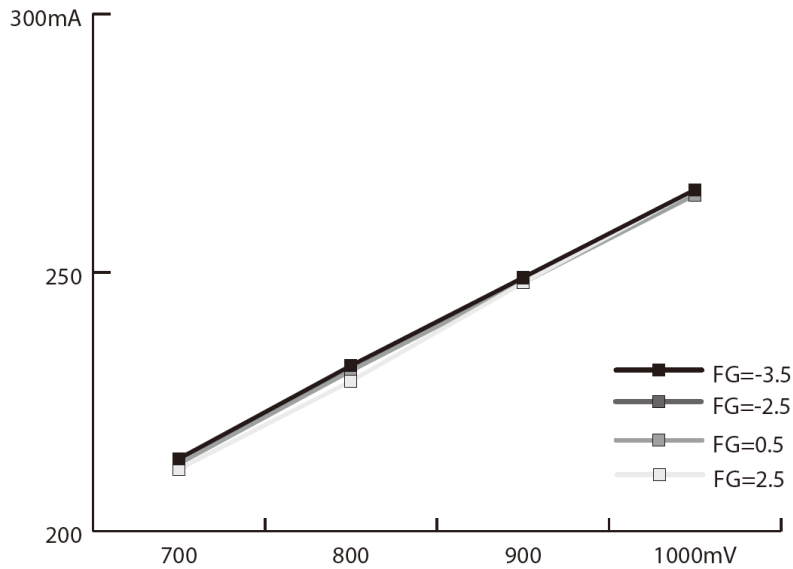

Figure 4-3 Power dissipation mA vs. SW[1:0] setting

PI3HDX1204E

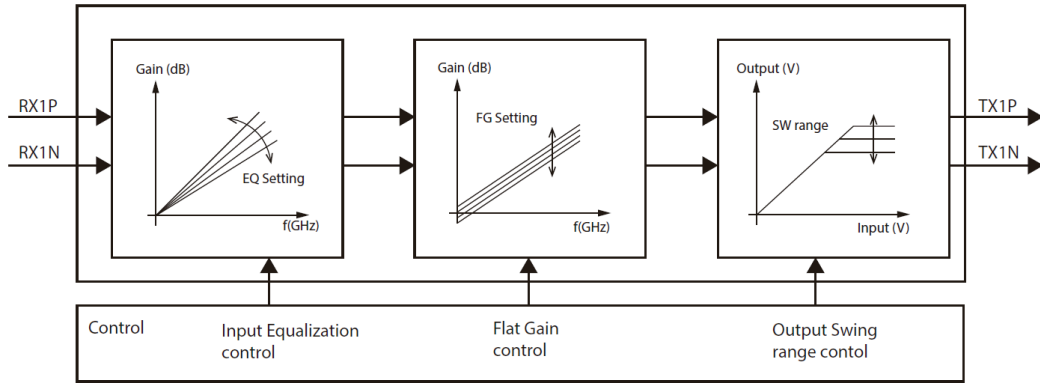

Figure 4-4 Illustration of EQ, Gain and Swing setting

5. I2C Programming

5.1 Programming Registers

5.1.1 I2C address

A6	A5	A4	A3	A2	A1	A0	R/W
1	1	1	AD3	AD2	AD1	AD0	1=R, 0=W

Note: (1) Address A0 is always "1" tied high for 32-pin package.

5.1.2 Configuration Registers

BYTE 0					
Bit	Type	Power up condition	Description	Control Affected	Comment
7:0	R		Reserved		

BYTE 1					
Bit	Type	Power up condition	Description	Control Affected	Comment
7:0	R		Reserved		

BYTE 2					
Bit	Type	Power up condition	Description	Control Affected	Comment
7	R/W	0		A3 Power down	1 = Power down
6	R/W	0		A2 Power down	
5	R/W	0		A1 Power down	
4	R/W	0		A0 Power down	
3	R/W	0		Reserved	
2	R/W	0		Reserved	
1	R/W	0		Reserved	
0	R/W	0		Reserved	

BYTE 3					
Bit	Type	Power up condition	Description	Control Affected	Comment
7	R/W	0	Channel A0 configuration	EQ3	Equalizer
6	R/W	0		EQ2	
5	R/W	0		EQ1	
4	R/W	0		EQ0	
3	R/W	0		FG1	Flat gain
2	R/W	0		FG0	
1	R/W	0		SW1	Swing
0	R/W	0		SW0	

PI3HDX1204E

BYTE 4					
Bit	Type	Power up condition	Description	Control Affected	Comment
7	R/W	0	Channel A1 configuration	EQ3	Equalizer
6	R/W	0		EQ2	
5	R/W	0		EQ1	
4	R/W	0		EQ0	
3	R/W	0		FG1	Flat gain
2	R/W	0		FG0	
1	R/W	0		SW1	Swing
0	R/W	0		SW0	

BYTE 5					
Bit	Type	Power up condition	Description	Control Affected	Comment
7	R/W	0	Channel A2 configuration	EQ3	Equalizer
6	R/W	0		EQ2	
5	R/W	0		EQ1	
4	R/W	0		EQ0	
3	R/W	0		FG1	Flat gain
2	R/W	0		FG0	
1	R/W	0		SW1	Swing
0	R/W	0		SW0	

BYTE 6					
Bit	Type	Power up condition	Description	Control Affected	Comment
7	R/W	0	Channel A3 configuration	EQ3	Equalizer
6	R/W	0		EQ2	
5	R/W	0		EQ1	
4	R/W	0		EQ0	
3	R/W	0		FG1	Flat gain
2	R/W	0		FG0	
1	R/W	0		SW1	Swing
0	R/W	0		SW0	

BYTE 7					
Bit	Type	Power up condition	Description	Control Affected	Comment
7:0	R/W		Reserved		

BYTE 8-15					
Bit	Type	Power up condition	Description	Control Affected	Comment
Power up condition : "0"					

5.2 I²C Operation

The integrated I2C interface operates as a slave device mode. Standard I2C mode (100 Kbps) is supported with 7-bit addressing and data byte format 8-bit.

The device supports Read/Write. The bytes must be accessed in sequential order from the lowest to the highest byte with the ability to stop after any complete byte has been transferred. Address bits A3 to A0 are programmable to support multiple chips environment.

The Data is loaded until a Stop sequence is issued.

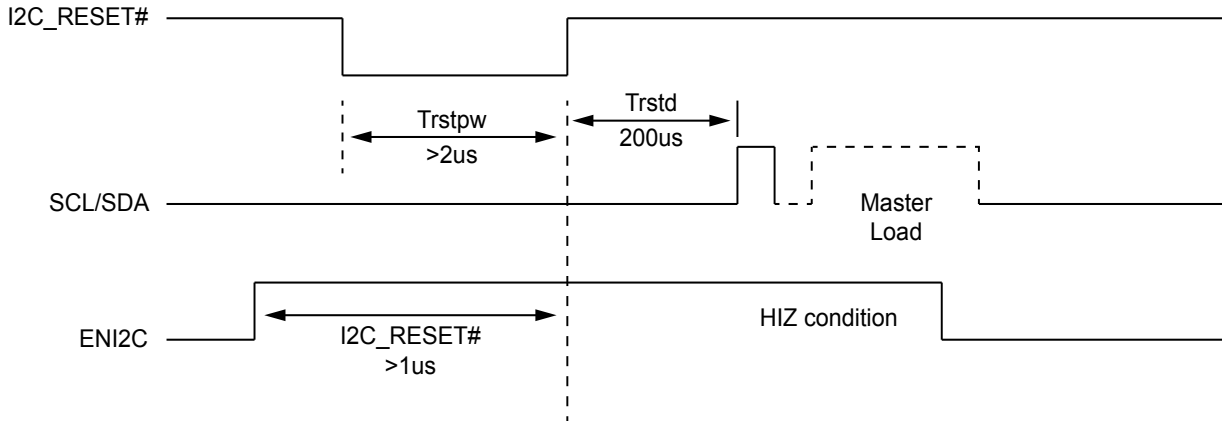

Figure 5-1 I2C Reset, Enable and SCL/SDA Timing Diagram

Transferring Data

Every byte put on the SDA line must be 8-bit long. Each byte has to be followed by an acknowledge bit. Data is transferred with the most significant bit (MSB) first (see the I2C Data Transfer diagram). It will never hold the clock line SCL LOW to force the master into a wait state.

Acknowledge

Data transfer with acknowledge is required from the master. When the master releases the SDA line (HIGH) during the acknowledge clock pulse, it will pull down the SDA line during the acknowledge clock pulse so that it remains stable LOW during the HIGH period of this clock pulse as indicated in the I2C Data Transfer diagram. It will generate an acknowledge after each byte has been received.

Data Transfer

A data transfer cycle begins with the master issuing a start bit. After recognizing a start bit, it will watch the next byte of information for a match with its address setting. When a match is found it will respond with a read or write of data on the following clocks. Each byte must be followed by an acknowledge bit, except for the last byte of a read cycle which ends with a stop bit. Data is transferred with the most significant bit (MSB) first.

Start & Stop Conditions

A HIGH to LOW transition on the SDA line while SCL is HIGH indicates a START condition. A LOW to HIGH transition on the SDA line while SCL is HIGH defines a STOP condition.

Table 5-1. I2C Address Setting with 4-bits AD[3:0]

I2C address: AD3, AD2, AD1, AD0	Data starting location
0000	00H
0001	10H
0010	20H
0011	30H
0100	40H
0101	50H
0110	60H
0111	70H
1000	80H
1001	90H
1010	A0H
1011	B0H
1100	C0H
1101	D0H
1110	E0H
1111	F0H

Read Sequence

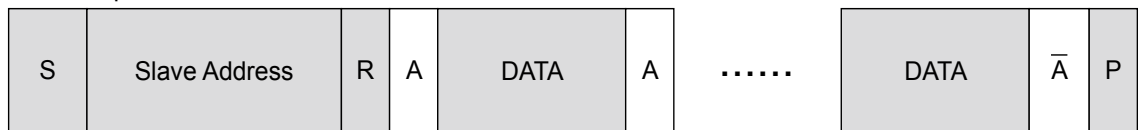

Write Sequence

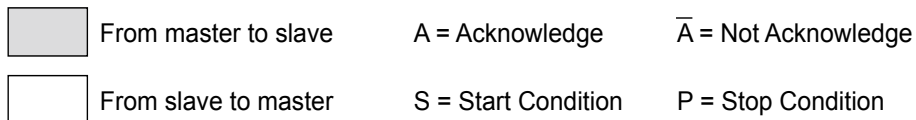
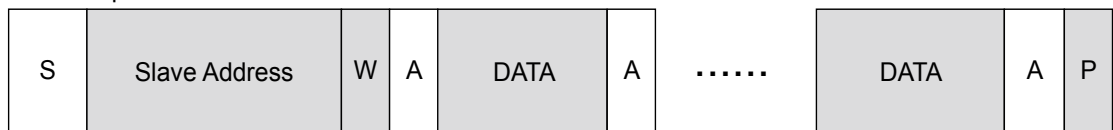

Figure 5-2 I2C Read / Write Timing Sequence

6. Electrical Specification

6.1 Absolute Maximum Ratings

Supply Voltage to Ground Potential.....	-0.5V to +4.6V
DC SIG Voltage.....	-0.5V to $V_{DD} + 0.5V$
Output Current.....	-25mA to +25mA
Power Dissipation Continuous.....	2.1W
ESD, HBM.....	-2kV to +2kV
Storage Temperature.....	-65°C to +150°C

Note
 (1) Stresses greater than those listed under MAXIMUM RATINGS may cause permanent damage to the device. This is a stress rating only and functional operation of the device at these or any other conditions above those indicated in the operational sections of this specification is not implied. Exposure to absolute maximum rating conditions for extended periods may affect reliability.

6.2 Recommended Operation Conditions

Parameter	Min.	Typ.	Max	Units
Power supply voltage (VDD to GND) ⁽¹⁾	3.0	3.3	3.6	V
I2C (SDA, SCL)			3.6	V
Supply Noise Tolerance up to 25 MHz ⁽²⁾			100	mVp-p
Ambient Temperature	-40	25	85	°C

Note
 (1) Typical parameters are measured at $V_{DD} = 3.3 \pm 0.3V$, $T_A = 25^\circ C$. They are for the reference purposes, and are not production-tested
 (2) Allow supply noise (mVp-p sine wave) under typical condition

6.3 Electrical Characteristics

Over recommend operating supply and temperature range unless otherwise specified.

6.3.1 LVC MOS DC Specifications

Symbol	Parameter	Conditions	Min.	Typ.	Max	Unit
V_{IH}	DC input logic high		$V_{DD}/2 + 0.7$		$V_{DD} + 0.3$	V
V_{IL}	DC input logic low		-0.3		$V_{DD}/2 - 0.7$	V
V_{OH}	At $I_{OH} = -200\mu A$		$V_{DD} + 0.2$			V
V_{OL}	At $I_{OL} = -200\mu A$				0.2	V
V_{hys}	Hysteresis of Schmitt trigger input		0.8			V

6.3.2 Power Dissipation

Symbol	Parameter	Conditions	Min.	Typ.	Max.	Units
I_{DD}	Supply current	PRSNT#=0, SW=1000mVdiff, FG=2.5		265	290	mA
		PRSNT#=0, SW=900mVdiff, FG=2.5		240	290	mA
		PRSNT#=0, SW=800mVdiff, FG=2.5		233	290	mA
I_{DDQ}	Quiescent Supply Current	PEN=0, TMDS Output Disable		2.0	4.2	mA

PI3HDX1204E
6.3.3 Package Power Ratings

Package	Theta Ja(still air) (°C/W)	Theta Jc (°C/W)	Max. Power Dissipation Rating (Ta ≤ 70°)
32-pin TQFN (ZL32)	37.05	11.3	1.48W
42-pin TQFN (ZH42)	33.69	15.17	1.63W

6.3.4 Switching I/O Characteristics

Symbol	Parameter	Conditions	Min.	Typ.	Max.	Units
V _{RX-DIFFP-P}	Peak to peak differential input voltage			200		mV
T _R	Rise Time	Input signal with 30ps rise time, 20% to 80%		31		ps
T _F	Falling Time	Input signal with 30ps rise time, 20% to 80%		31		ps
T _{PLH}	Low-to-High Propagation Delay			65		ps
T _{PHL}	High-to-Low Propagation Delay			65		ps
T _{SK_IN-TRA_IN}	Input Intra-pair Differential Skew tolerance				0.15	IU
T _{SK_INTRA_OUT}	Output Intra-pair Differential Skew			5	10	ps
T _{SK_INTER_OUT}	Output Inter-pair Differential Skew			8		ps
R _J	Add-in Random Jitter	at 6Gbps		0.57		RMS ps
D _J	Add-in Deterministic Jitter	at 6Gbps		6.57		ps
T _{SX}	Select to Switch Output				10	ns
S ₂₂	Output return loss	10 MHz to 6 Gbps differential		13		dB
		2 Gbps to 6 Gbps common mode		8		
R _{IN}	DC single-ended input impedance			50		Ω
	DC Differential Input Impedance			100		
R _{OUT}	DC single-ended output impedance			50		Ω
	DC Differential output Impedance			100		
Z _{RX-HIZ}	DC input CM input impedance during reset or power down			200		kΩ
V _{RX-DIFFPP}	Differential Input Peak-to-peak Voltage	Operational			1.4	V _{ppd}
V _{CMNOISE}	Input source common-mode noise	DC – 200MHz			150	mV _{ppd}
TTX-IDLE-SET-TOIDLE	Max time to electrical idle after sending an EIOS			4	8	ns
TTX-IDLETO-DIFFDATA	Max time to valid differential signal after leaving electrical idle			4	8	ns
T _{PD}	Latency	From input to output		0.5		ns

PI3HDX1204E

Symbol	Parameter	Conditions	Min.	Typ.	Max.	Units
G _p	Peaking gain (Compensation at 6Gbps, relative to 100MHz, 100mV _{p-p} sine wave input)	EQ<3:0> = 1111 EQ<3:0> = 1000 EQ<3:0> = 0000		8.9 6.6 3.6		dB
		Variation around typical	-3		+3	dB
G _F	Flat gain (100MHz, EQ<3:0> = 1000, SW<1:0> = 10)	FG<1:0> = 11 FG<1:0> = 10 FG<1:0> = 01 FG<1:0> = 00		-3.5 -1.5 0.5 2.5		dB
		Variation around typical	-3		+3	dB
V _{1dB_100M}	-1dB compression point of output swing (at 100MHz)	SW<1:0> = 11 SW<1:0> = 10 SW<1:0> = 01 SW<1:0> = 00		1400 1300 1200 1100		mV _{ppd}
V _{1dB_6G}	-1dB compression point of output swing (at 6 Gbps)	SW<1:0> = 11 SW<1:0> = 10 SW<1:0> = 01 SW<1:0> = 00		1300 1200 1100 1000		mV _{ppd}
V _{Coup}	Channel isolation	100MHz to 6 Gbps		40		dB
V _{noise_input}	Input-referred noise ⁽²⁾	100MHz to 6 Gbps, FG<1:0> = 11, EQ<3:0> = 0000		0.5		mV _{RMS}
		100MHz to 6 Gbps, FG<1:0> = 11, EQ<3:0> = 1010		0.4		
V _{noise_output}	Output-referred noise ⁽²⁾	100MHz to 6 Gbps, FG<1:0> = 11, EQ<3:0> = 0000		0.7		mV _{RMS}
		100MHz to 6 Gbps, FG<1:0> = 11, EQ<3:0> = 1010		0.8	1.6	

Note:
 (1) Measured using a vector-network analyzer (VNA) with -15dBm power level applied to the adjacent input. The VNA detects the signal at the output of the victim channel. All other inputs and outputs are terminated with 50Ω.
 (2) Guaranteed by design.

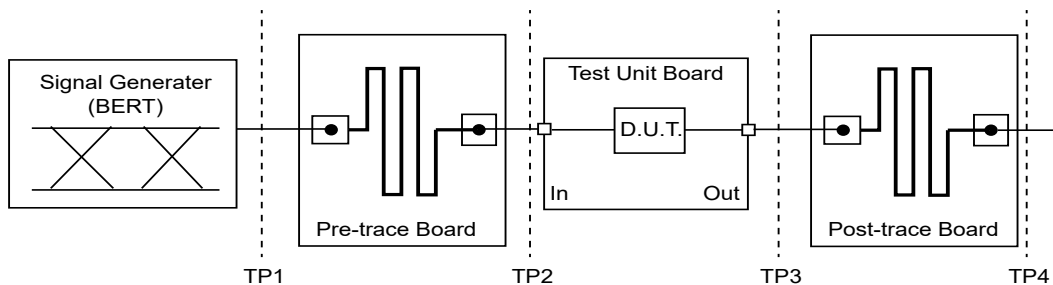

Figure 6-1 Electrical Parameter Test Setup

PI3HDX1204E

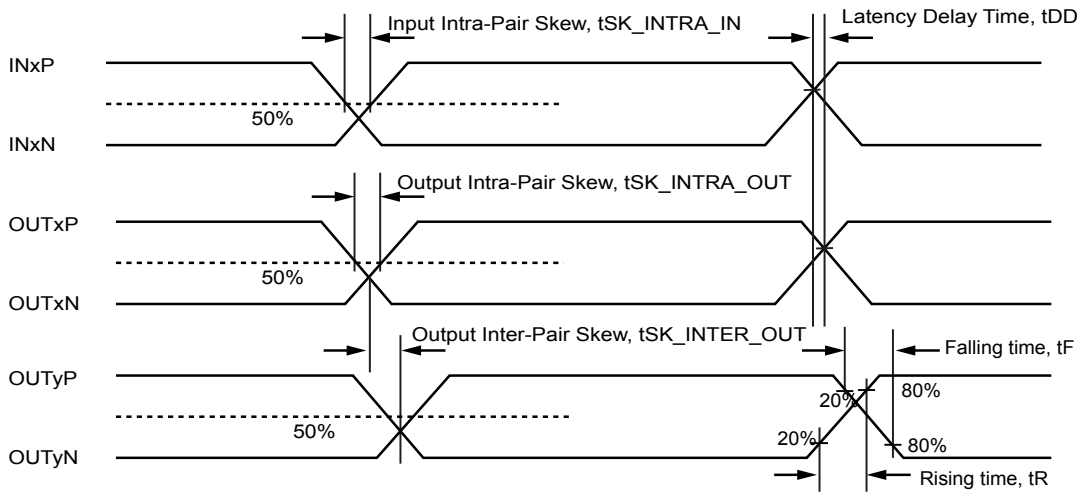
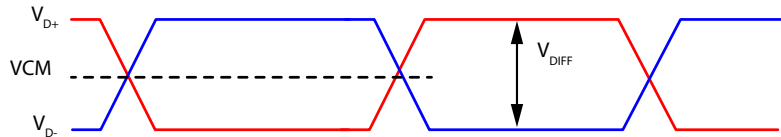

Figure 6-2 Intra and Inter-pair Differential Skew Definition

Common Mode Voltage
 $V_{CM} = (|VD+ + VD-| / 2)$
 $V_{CMP} = (\max |VD+ + VD-| / 2)$



$V_{D+} - V_{D-}$

Symmetric Differential Swing
 $V_{DIFFP-P} = (2 * \max |V_{D+} - V_{D-}|)$

Asymmetric Differential Swing
 $V_{DIFFP-P} = (\max |V_{D+} - V_{D-}| \{V_{D+} > V_{D-}\} + \max |V_{D+} - V_{D-}| \{V_{D+} < V_{D-}\})$

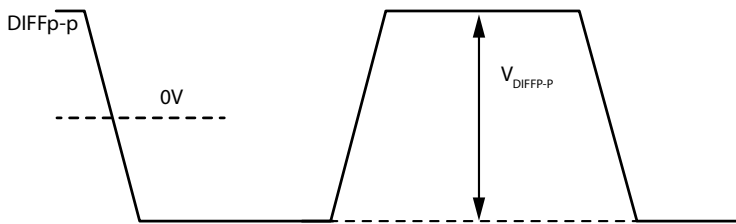

Figure 6-3 Definition of Peak-to-peak Differential Voltage

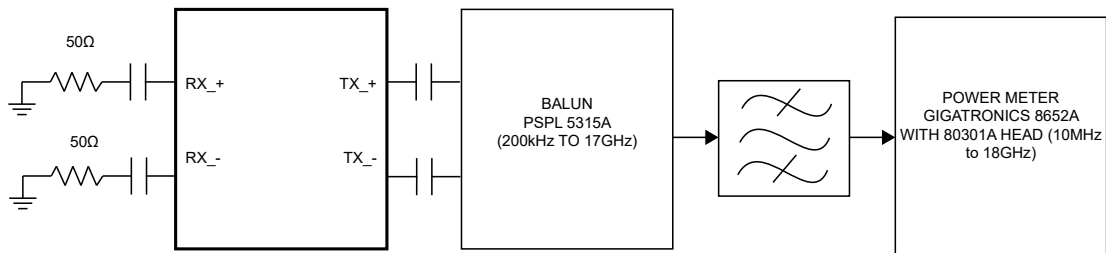

Figure 6-4 Noise Test Configuration

PI3HDX1204E

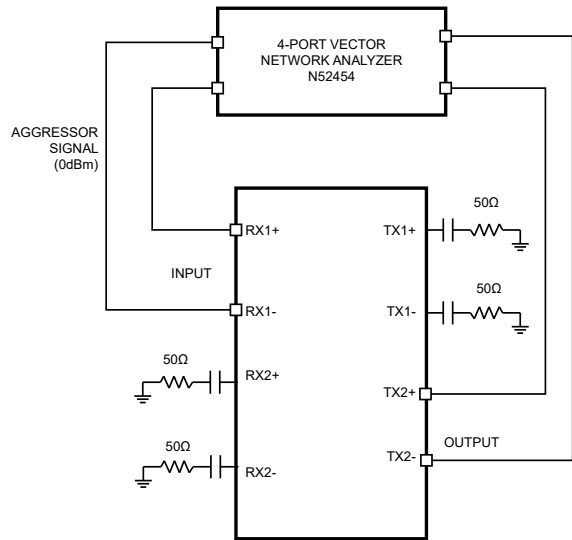

Figure 6-5 Channel-isolation Test Configuration

6.4 I2C Bus

Symbol	Parameter	Conditions	Min.	Typ.	Max	Units
VDD	Nominal Bus Voltage		3.0		3.6	V
Freq	Bus Operation Frequency				400	kHz
V _{IH}	DC input logic high		$V_{DD}/2 + 0.7$		$V_{DD} + 0.3$	V
V _{IL}	DC input logic low		-0.3		$V_{DD}/2 - 0.7$	V
V _{OL}	DC output logic low	I _{OL} = 3mA			0.4	V
I _{pullup}	Current Through Pull-Up Resistor or Current Source	High Power specification	3.0		3.6	mA
I _{leak-bus}	Input leakage per bus segment		-200		200	uA
I _{leak-pin}	Input leakage per device pin			-15		uA
CI	Capacitance for SDA/SCL				10	pF
t _{BUF}	Bus Free Time Between Stop and Start condition		1.3			us
t _{HD:STA}	Hold time after (Repeated) Start condition. After this period, the first clock is generated.	At pull-up, Max	0.6			us
TSU:STA	Repeated start condition setup time		0.6			us
TSU:STO	Stop condition setup time		0.6			us
THD:DAT	Data hold time		0			ns
TSU:DAT	Data setup time		100			ns
t _{LOW}	Clock low period		1.3			us
t _{HIGH}	Clock high period		0.6		50	us
t _F	Clock/Data fall time				300	ns
t _R	Clock/Data rise time				300	ns
t _{POR}	Time in which a device must be operation after power-on reset				500	ms

Note:

- (1) Recommended maximum capacitance load per bus segment is 400pF.
- (2) Compliant to I2C physical layer specification.
- (3) Ensured by Design. Parameter not tested in production.

PI3HDX1204E

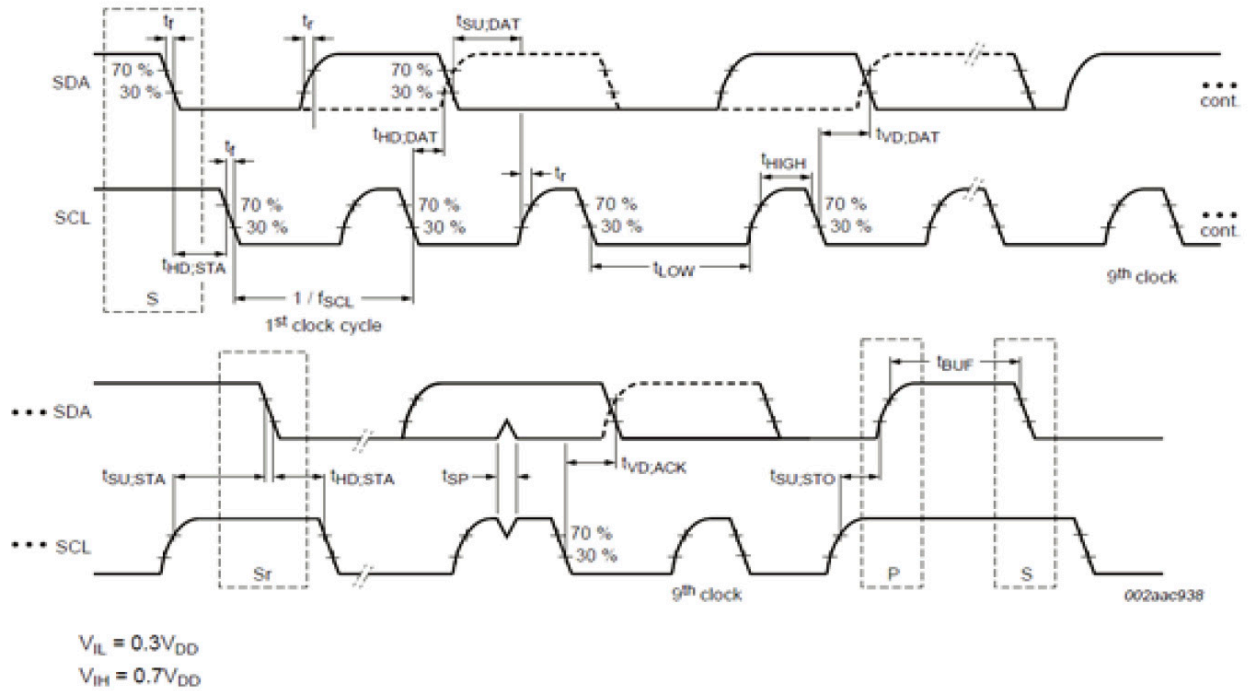
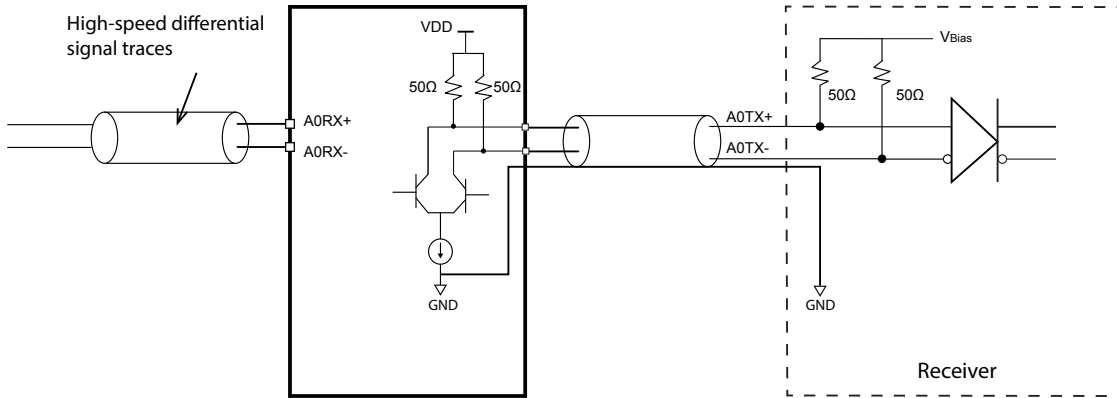

Figure 6-6 I2C Timing Definition

7. Applications

7.1 DC/AC-coupled Application



DC-Coupled Differential Signaling Application Circuits

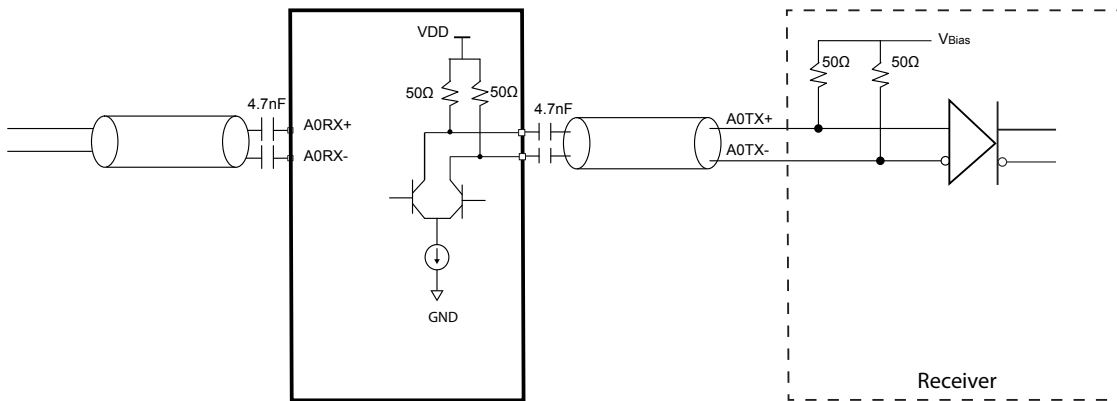

AC-Coupled Differential Signaling Application Circuits

Figure 7-1 DC/AC-coupled Application Diagram

7.2 Sink-side Redriver Application

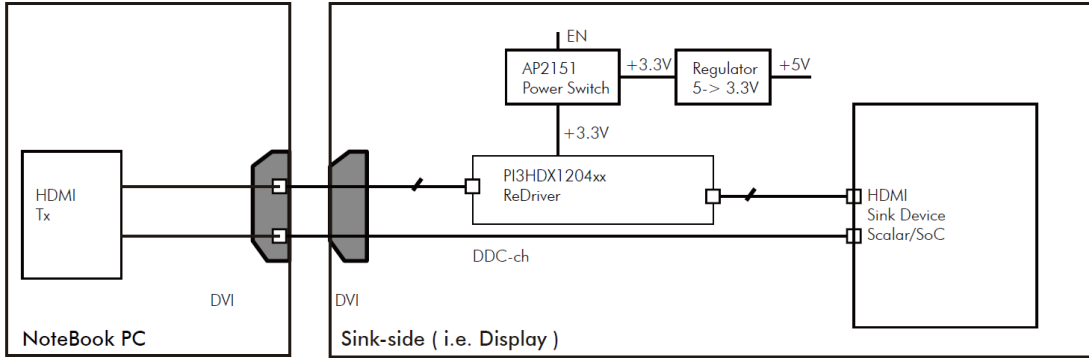

Figure 7-2 HDMI Sink-side Application

7.3 Channels/Polarity Swap

Linear Redriver does not have built-in internal channel/polarity switch. Transmitter can send swapped polarity signal to the Redriver.

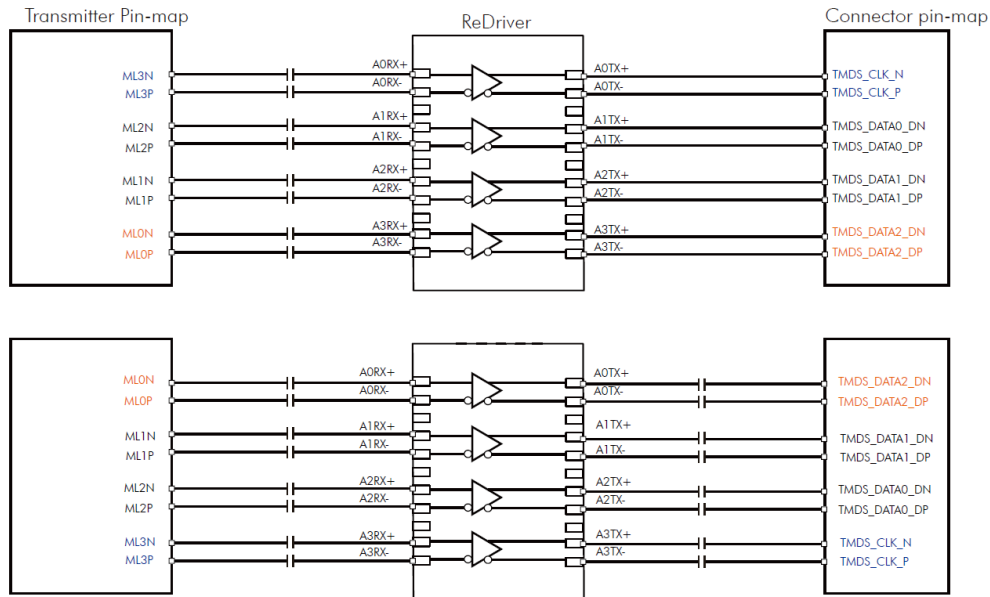

Figure 7-3 Polarity Swap Connection

PI3HDX1204E

7.4 Output Eye Diagram

7.4.1 Trace Card Loss Informations

Frequency	3 GHz	6GHz	Units
6 inch Input Trace	-1.43	-4	dB
12 inch Input Trace	-6.1	-11	dB
18 inch Input Trace	-8.34	-15	dB
30 inch Input Trace	-10.14	-18	dB
36 inch Input Trace	-12.13	-22	dB
48 inch Input Trace	-16.42	-29	dB

Table 7-1. Characterization Trace Card dB Loss Information

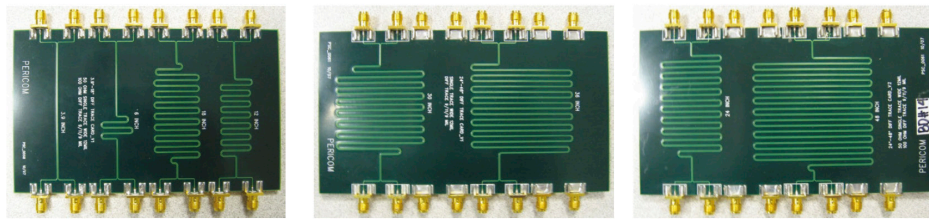

Figure 7-4 Trace board photo

7.4.2 Output Eye Diagram Measurement

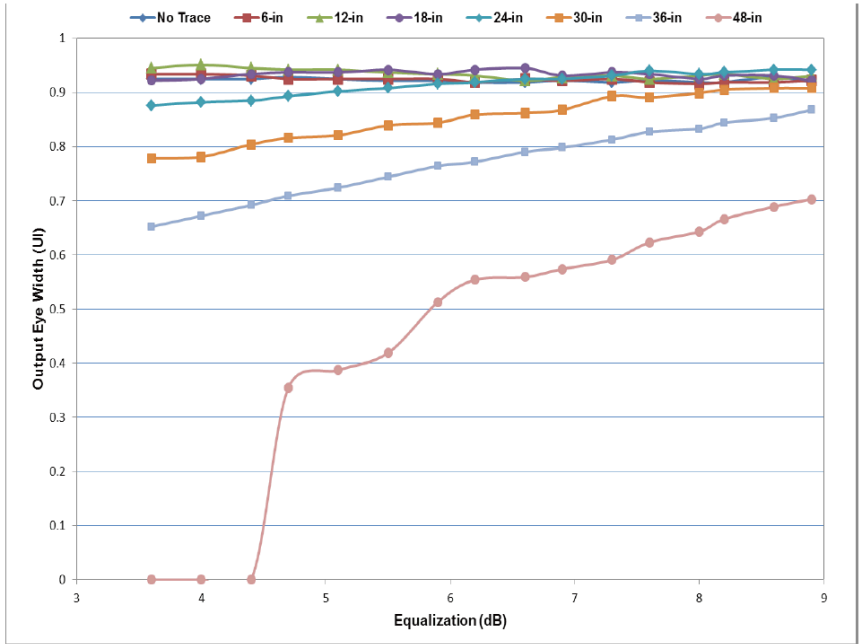

Figure 7-5 Eye Width vs. EQ plots at 6 Gbps, PRBS2²³-1, FG=11 (Gain +2.5dB)
Eye Width vs EQ, FG =1000mV, Gain=+2.5dB (Input Swing=800mVd)

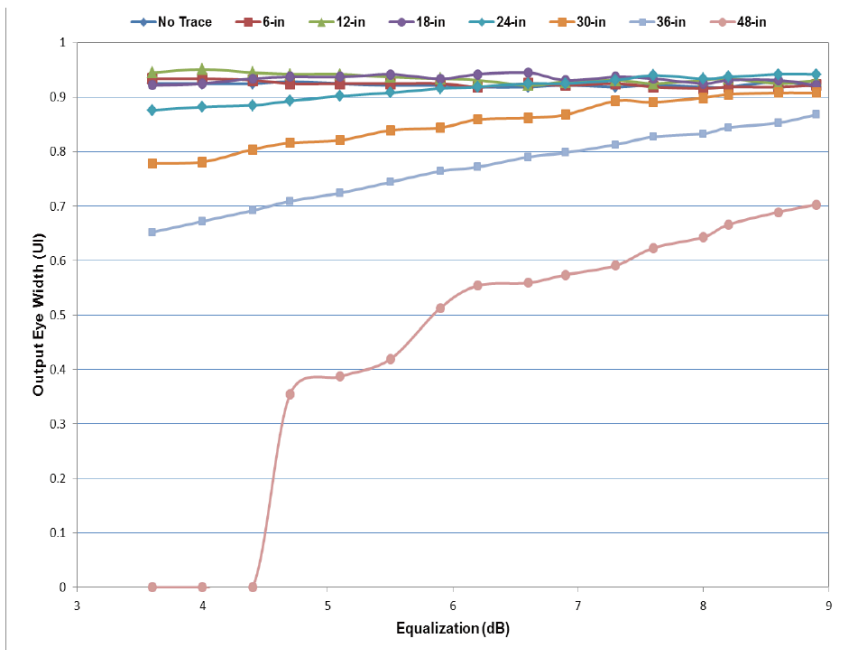

Figure 7-6 Eye Width vs. EQ plots at 6 Gbps, PRBS2²³-1, FG=10 (Gain +0.5dB)
Eye Height vs EQ, FG=1000mV, Gain=+2.5dB (input swing=800mVd)

PI3HDX1204E

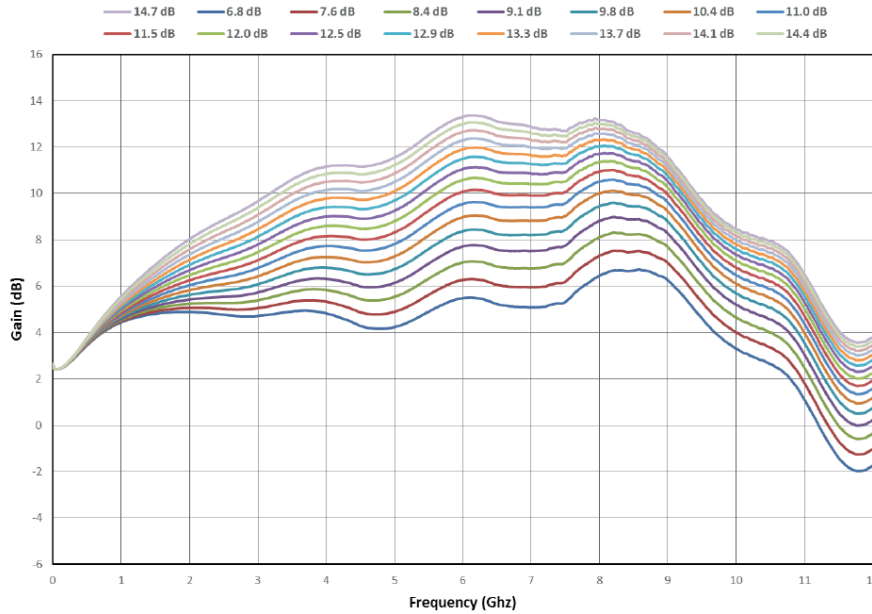
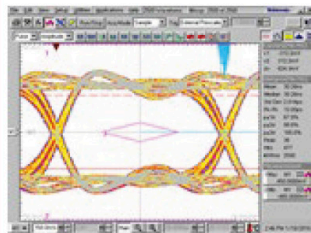
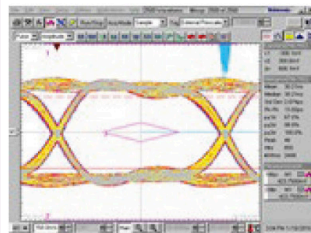
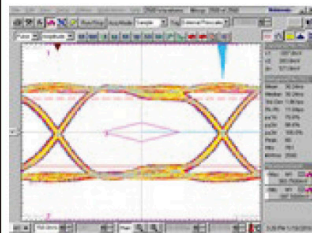
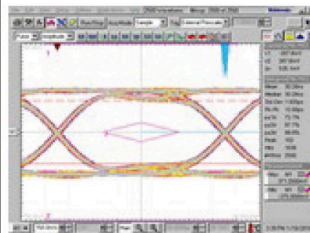
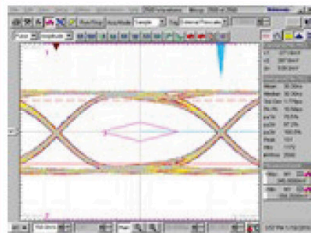
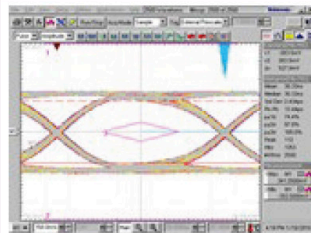
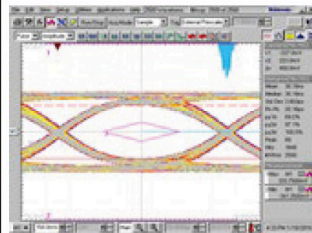
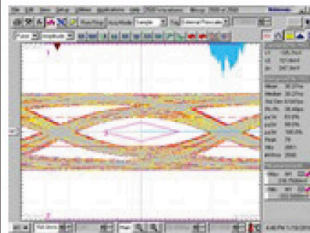

Figure 7-7 Frequency response vs EQ
with FG=11(+2.5dB), Output Swing=1000mV, Vdd=3.0V, 25C, Input Power=-15dBm, No Input Trace

7.4.3 Output Eye Diagram

Condition: PRBS 2²³-1 pattern, Input Swing=800mVdiff, Output Swing= 1000mVdiff

Table 7-2. Output Eye diagram by EQ changes at FG 0.5dB

No Trace, FG=0.5dB 	6-in trace, FG=0.5dB 	12-in trace, FG=0.5dB 	18-in trace, FG=0.5dB 
EQ=3dB	EQ=3dB	EQ=5dB	EQ=6dB
24-in trace, FG=0.5dB 	30-in trace, FG=0.5dB 	36-in trace, FG=0.5dB 	48-in trace, FG=0.5dB 
EQ=10dB	EQ=13.3dB	EQ=14.5dB	EQ=15dB

PI3HDX1204E

Table 7-3. Output Eye Diagram by EQ changes at FG 2.5dB

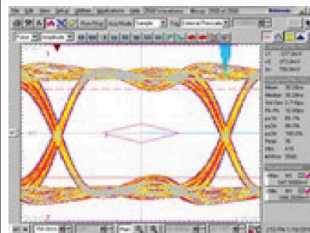
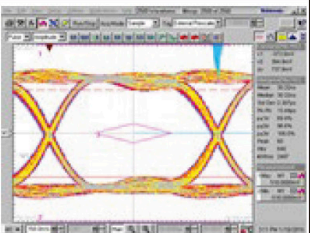
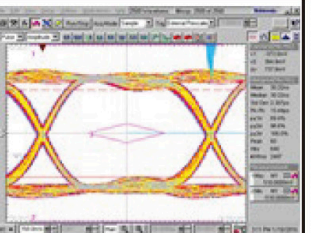
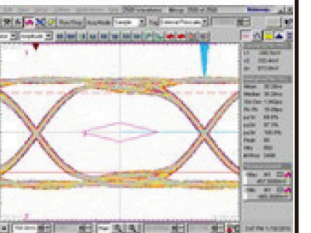
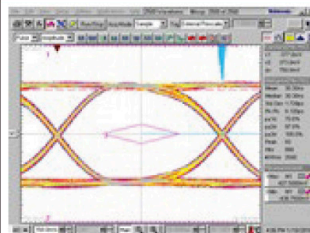
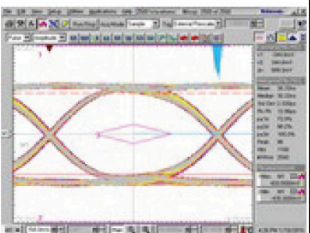
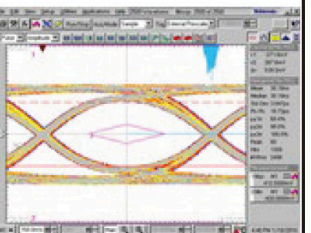
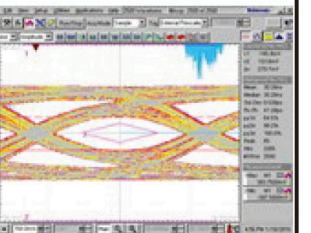
No Trace, FG=2.5dB	6-in trace, FG=2.5dB	12-in trace, FG=2.5dB	18-in trace, FG=2.5dB
 EQ=3dB	 EQ=3dB	 EQ=5dB	 EQ=8dB
24-in trace, FG=2.5dB	30-in trace, FG=2.5dB	36-in trace, FG=2.5dB	48-in trace, FG=2.5dB
 EQ=13dB	 EQ=15dB	 EQ=15dB	 EQ=15dB

7.5 Layout Guideline

As transmission data rate increases rapidly, any flaws and/or mis-matches on PCB layout are amplified in terms of signal integrity. Layout guideline for high-speed transmission is highlighted in this application note.

7.5.1 Power and Ground

To provide a clean power supply for Pericom high-speed device, few recommendations are listed below:

- Power (VDD) and ground (GND) pins should be connected to corresponding power planes of the printed circuit board directly without passing through any resistor.
- The thickness of the PCB dielectric layer should be minimized such that the VDD and GND planes create low inductance paths.
- One low-ESR 0.1uF decoupling capacitor should be mounted at each VDD pin or should supply bypassing for at most two VDD pins. Capacitors of smaller body size, i.e. 0402 package, is more preferable as the insertion loss is lower. The capacitor should be placed next to the VDD pin.
- One capacitor with capacitance in the range of 4.7uF to 10uF should be incorporated in the power supply decoupling design as well. It can be either tantalum or an ultra-low ESR ceramic.
- A ferrite bead for isolating the power supply for Pericom high-speed device from the power supplies for other parts on the printed circuit board should be implemented.
- Several thermal ground vias must be required on the thermal pad. 25-mil or less pad size and 14-mil or less finished hole are recommended.

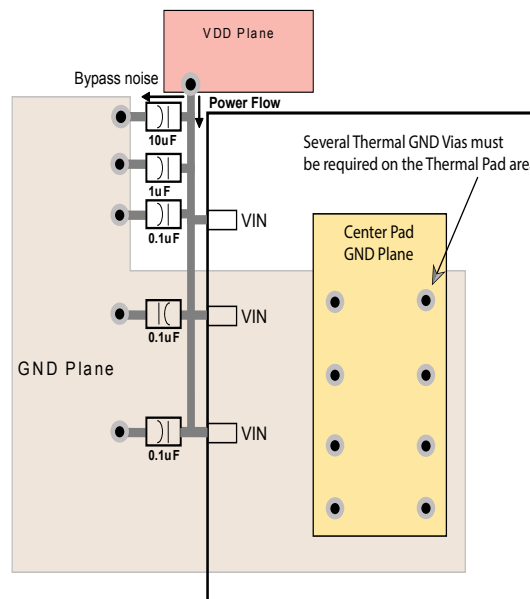

Figure 7-8 Decoupling Capacitor Placement Diagram

PI3HDX1204E

7.5.2 High-speed signal Routing

Well-designed layout is essential to prevent signal reflection:

- For 90Ω differential impedance, width-spacing-width micro-strip of 6-7-6 mils is recommended; for 100Ω differential impedance, width-spacing-width micro-strip of 5-7-5 mils is recommended.
- Differential impedance tolerance is targeted at ±15%.

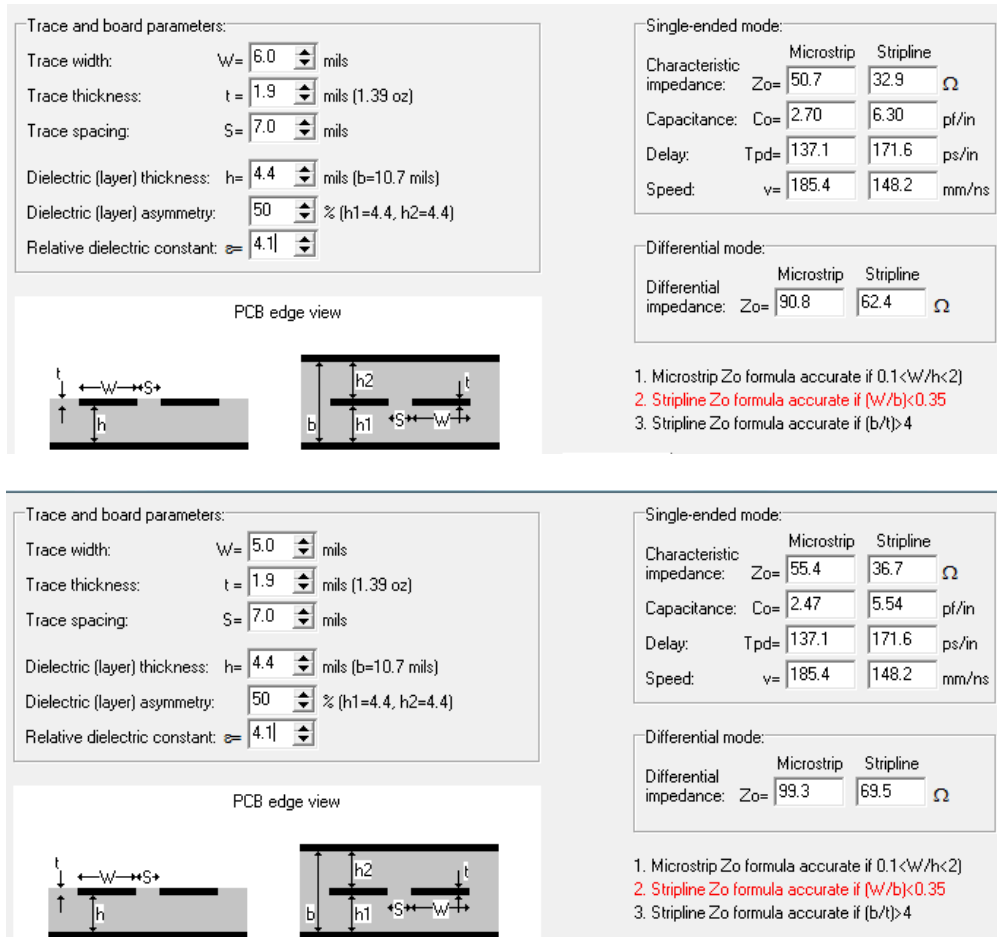

Figure 7-9 Trace Width and Clearance of Micro-strip and Strip-line

PI3HDX1204E

- For micro-strip, using 1/2oz Cu is fine. For strip-line in 6+ PCB layers, 1oz Cu is more preferable.

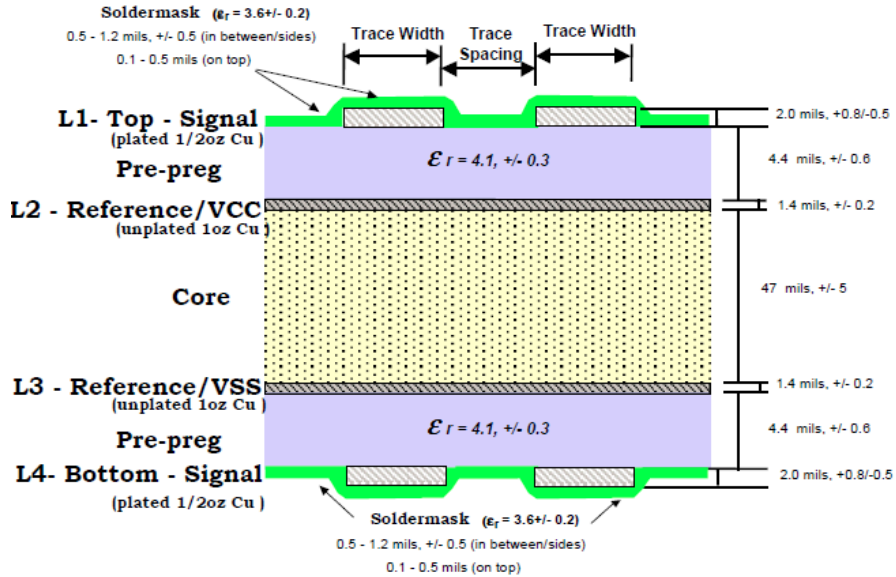

Figure 7-10 4-Layer PCB Stack-up Example

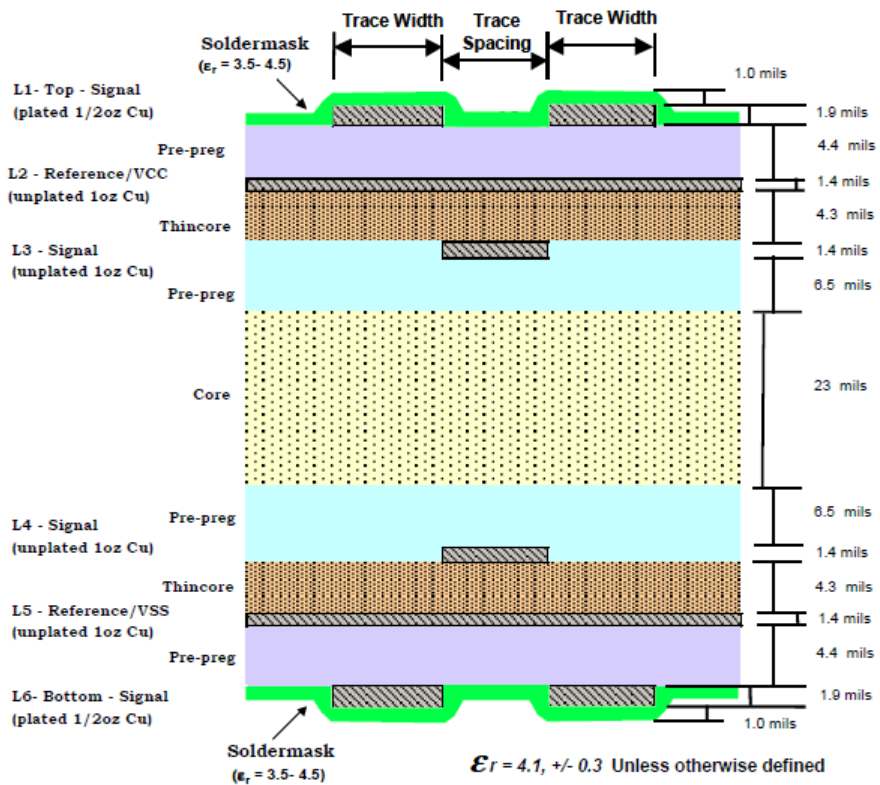

Figure 7-11 6-Layer PCB Stack-up Example

- Ground referencing is highly recommended. If unavoidable, stitching capacitors of 0.1uF should be placed when reference plane is changed.

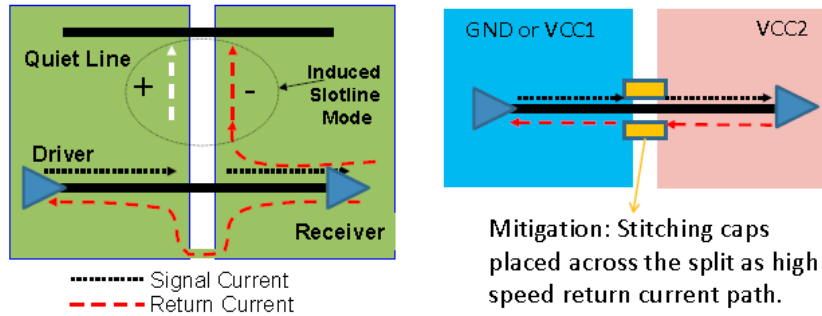

Figure 7-12 Stitching Capacitor Placement

- To keep the reference unchanged, stitching vias must be used when changing layers.
- Differential pair should maintain symmetrical routing whenever possible. The intra-pair skew of micro-strip should be less than 5 mils.
- To keep the reference unchanged, stitching vias must be used when changing layers.
- Differential pair should maintain symmetrical routing whenever possible. The intra-pair skew of micro-strip should be less than 5 mils.

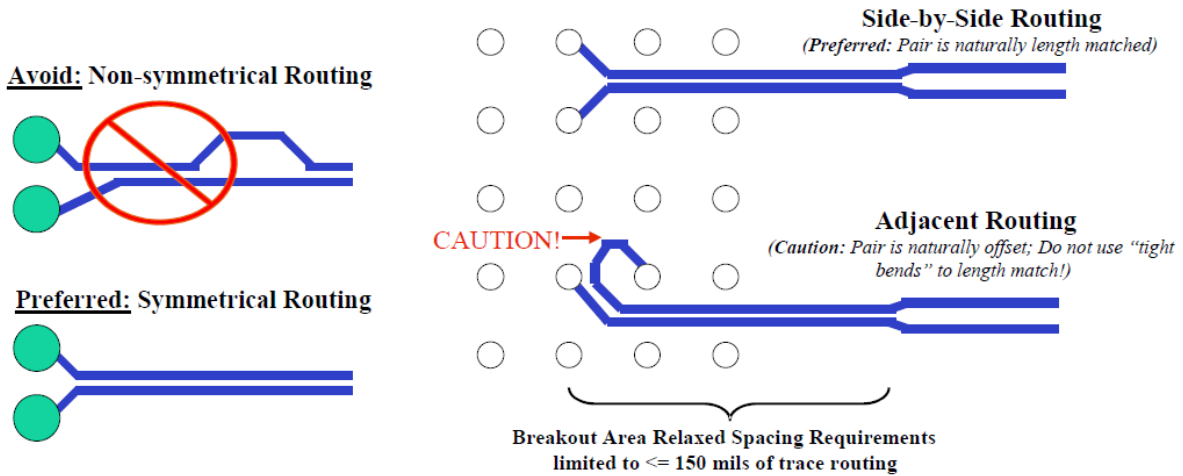

Figure 7-13 Layout Guidance of Matched Differential Pair

- For minimal crosstalk, inter-pair spacing between two differential micro-strip pairs should be at least 20 mils or 4 times the dielectric thickness of the PCB.
- Wider trace width of each differential pair is recommended in order to minimize the loss, especially for long routing. More consistent PCB impedance can be achieved by a PCB vendor if trace is wider.
- Differential signals should be routed away from noise sources and other switching signals on the printed circuit board.
- To minimize signal loss and jitter, tight bend is not recommended. All angles α should be at least 135 degrees. The inner air gap A should be at least 4 times the dielectric thickness of the PCB.

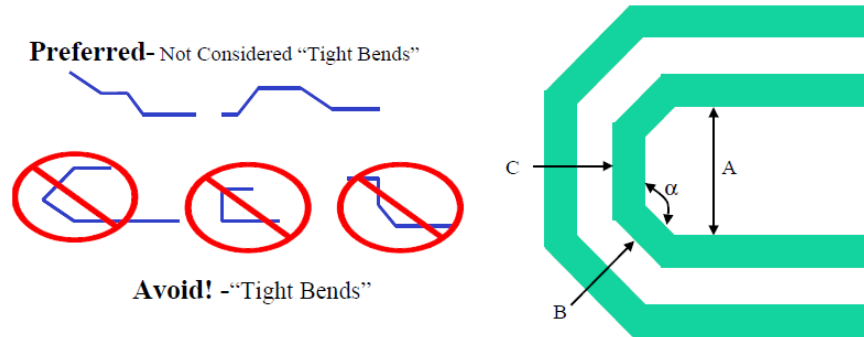

Figure 7-14 Layout Guidance of Bends

- Stub creation should be avoided when placing shunt components on a differential pair.

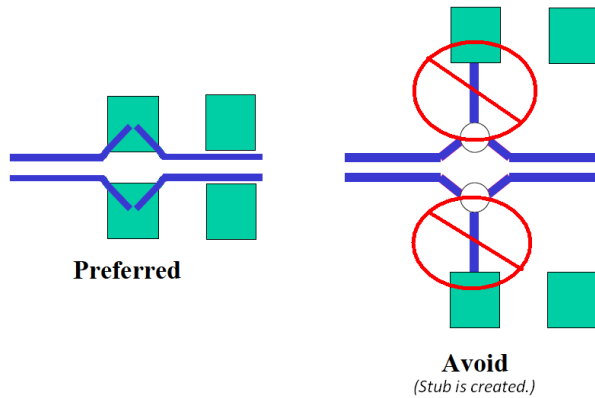

Figure 7-15 Layout Guidance of Shunt Component

- Placement of series components on a differential pair should be symmetrical.

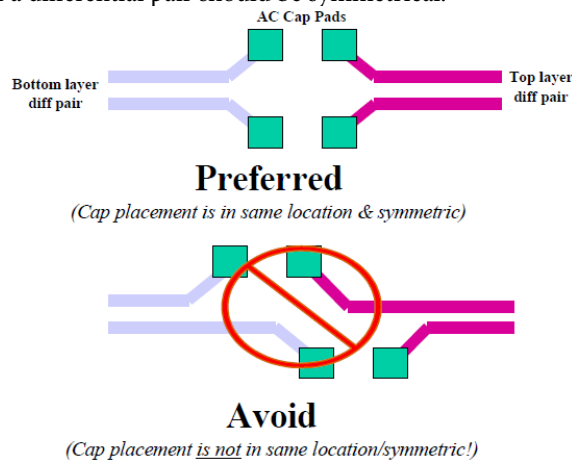
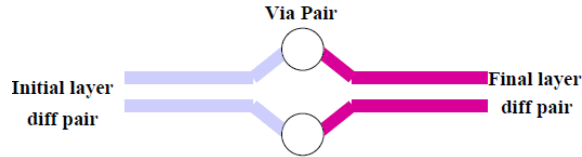

Figure 7-16 Layout Guidance of Series Component

- Stitching vias or test points must be used sparingly and placed symmetrically on a differential pair.



Preferred

(Via placement is in same location & symmetric)

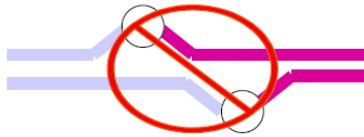

Avoid

(Via placement is not in same location/symmetric!)

Figure 7-17 Layout Guidance of Stitching Via

PI3HDX1204E

7.6 HDMI 2.0 Compliance Test

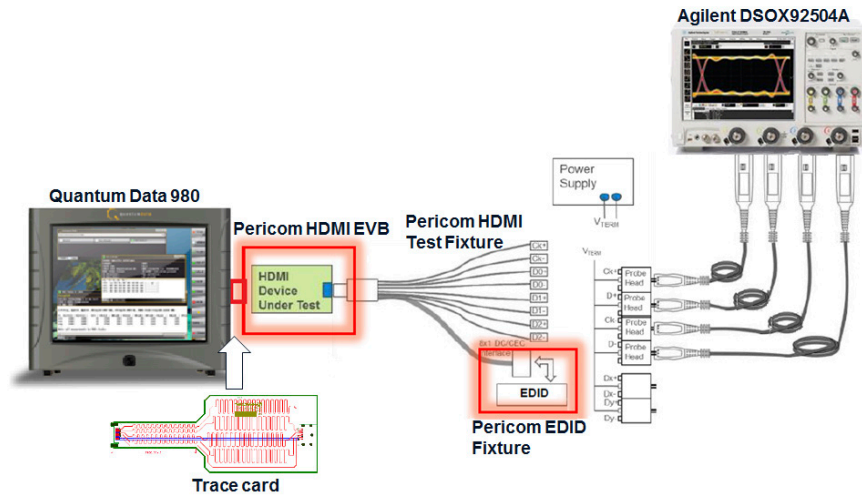

Figure 7-18 HDMI 2.0 CTS test setup

Note: Application Trace Card Information for CTS test

Table 7-4. Application Trace Card Information for CTS test

HDMI FR4 trace	0 in	6 in	12 in	18 in	24 in	30 in	36 in
Insertion loss @ 6Gbps	-5.91 dB	-9.75 dB	-10.47 dB	-13.05 dB	-15.87 dB	-16.97 dB	-21.20 dB

PI3HDX1204E

HDMI Test Report

Overall Result: PASS

Test Configuration Details	
Device Description	
Device ID	Transmitter
Fixture Type	Other
Probe Connection	4 Probes
Probe Head Type	N5444A
Lane Connection	1 Data Lane
HDMI Specification	2.0
HDMI Test Type	TMD5 Physical Layer Tests
Test Session Details	
Infiniium SW Version	05.20.0013
Infiniium Model Number	DSOX92504A
Infiniium Serial Number	MY54410104
Application SW Version	2.11
Debug Mode Used	No
Probe (Channel 1)	Model: N2801A Serial: US54094067 Head: N5444A Atten: Calibrated (18 FEB 2015 11:16:48), Using Cal Atten (5.7831E+000) Skew: Calibrated (18 FEB 2015 11:16:56), Using Cal Skew
Probe (Channel 2)	Model: N2801A Serial: US54094054 Head: N5444A Atten: Calibrated (18 FEB 2015 11:19:29), Using Cal Atten (5.5882E+000) Skew: Calibrated (18 FEB 2015 11:13:57), Using Cal Skew
Probe (Channel 3)	Model: N2801A Serial: US54094059 Head: N5444A Atten: Calibrated (18 FEB 2015 11:15:19), Using Cal Atten (5.7320E+000) Skew: Calibrated (18 FEB 2015 11:15:29), Using Cal Skew
Probe (Channel 4)	Model: N2801A Serial: US54094057 Head: N5444A Atten: Calibrated (18 FEB 2015 11:11:30), Using Cal Atten (5.5123E+000) Skew: Calibrated (18 FEB 2015 11:12:12), Using Cal Skew
Last Test Date	2016-01-21 16:43:22 UTC +08:00

Figure 7-19 HDMI 2.0 CTS Test Report

PI3HDX1204E

Summary of Results

Test Statistics	
Failed	0
Passed	24
Total	24

Margin Thresholds	
Warning	< 2 %
Critical	< 0 %

Pass	# Failed	# Trials	Test Name	Actual Value	Margin	Pass Limits
✓	0	1	<u>HF1-2: Clock Rise Time</u>	151.367 ps	101.8 %	VALUE >= 75.000 ps
✓	0	1	<u>HF1-2: Clock Fall Time</u>	150.838 ps	101.1 %	VALUE >= 75.000 ps
✓	0	1	<u>HF1-6: Clock Duty Cycle(Minimum)</u>	49.780	24.5 %	>=40%
✓	0	1	<u>HF1-6: Clock Duty Cycle(Maximum)</u>	50.330	16.1 %	<=60%
✓	0	1	<u>HF1-6: Clock Rate</u>	148.513500000 MHz	2.3 %	85.000000000 MHz <= VALUE <= 150.000000000 MHz
✓	0	1	<u>HF1-7: Differential Clock Voltage Swing, Vs (TP1)</u>	997 mV	25.4 %	400 mV < VALUE < 1.200 V
✓	0	1	<u>HF1-7: Clock Jitter (TP2 EQ with Worst Case Positive Skew)</u>	250 mTbit	16.7 %	VALUE <= 300 mTbit
✓	0	1	<u>HF1-7: Clock Jitter (TP2 EQ with Worst Case Negative Skew)</u>	225 mTbit	25.0 %	VALUE <= 300 mTbit
✓	0	1	<u>HF1-5: D0 Maximum Differential Voltage</u>	542 m	30.5 %	VALUE <= 780 m
✓	0	1	<u>HF1-5: D0 Minimum Differential Voltage</u>	-564 m	27.7 %	VALUE >= -780 m
✓	0	1	<u>HF1-2: D0 Rise Time</u>	135.000 ps	217.6 %	VALUE >= 42.500 ps
✓	0	1	<u>HF1-2: D0 Fall Time</u>	134.370 ps	216.2 %	VALUE >= 42.500 ps
✓	0	1	<u>HF1-8: D0 Mask Test (TP2 EQ with Worst Case Positive Skew)</u>	0.000	50.0 %	No Mask Failures
✓	0	1	<u>HF1-8: D0 Mask Test (TP2 EQ with Worst Case Negative Skew)</u>	0.000	50.0 %	No Mask Failures
✓	0	1	<u>HF1-1: VL Clock +</u>	2.684 V	48.0 %	2.300 V <= VALUE <= 3.100 V
✓	0	1	<u>HF1-1:Clock + VSwing</u>	513 mV	21.8 %	200 mV <= VALUE <= 600 mV
✓	0	1	<u>HF1-1: VL Clock -</u>	2.678 V	47.3 %	2.300 V <= VALUE <= 3.100 V
✓	0	1	<u>HF1-1:Clock - VSwing</u>	513 mV	21.8 %	200 mV <= VALUE <= 600 mV
✓	0	1	<u>HF1-4: Intra-Pair Skew - Clock</u>	51 mTbit	33.0 %	-150 mTbit <= VALUE <= 150 mTbit
✓	0	1	<u>HF1-1: VL D0+</u>	2.706 V	32.3 %	2.300 V <= VALUE <= 2.900 V
✓	0	1	<u>HF1-1: D0+ VSwing</u>	459 mV	29.5 %	400 mV <= VALUE <= 600 mV
✓	0	1	<u>HF1-1: VL D0-</u>	2.718 V	30.3 %	2.300 V <= VALUE <= 2.900 V
✓	0	1	<u>HF1-1: D0- VSwing</u>	450 mV	25.0 %	400 mV <= VALUE <= 600 mV
✓	0	1	<u>HF1-4: Intra-Pair Skew - Data Lane 0</u>	36 mTbit	38.0 %	-150 mTbit <= VALUE <= 150 mTbit

PI3HDX1204E

8. Mechanical/Packaging Information

8.1 Mechanical

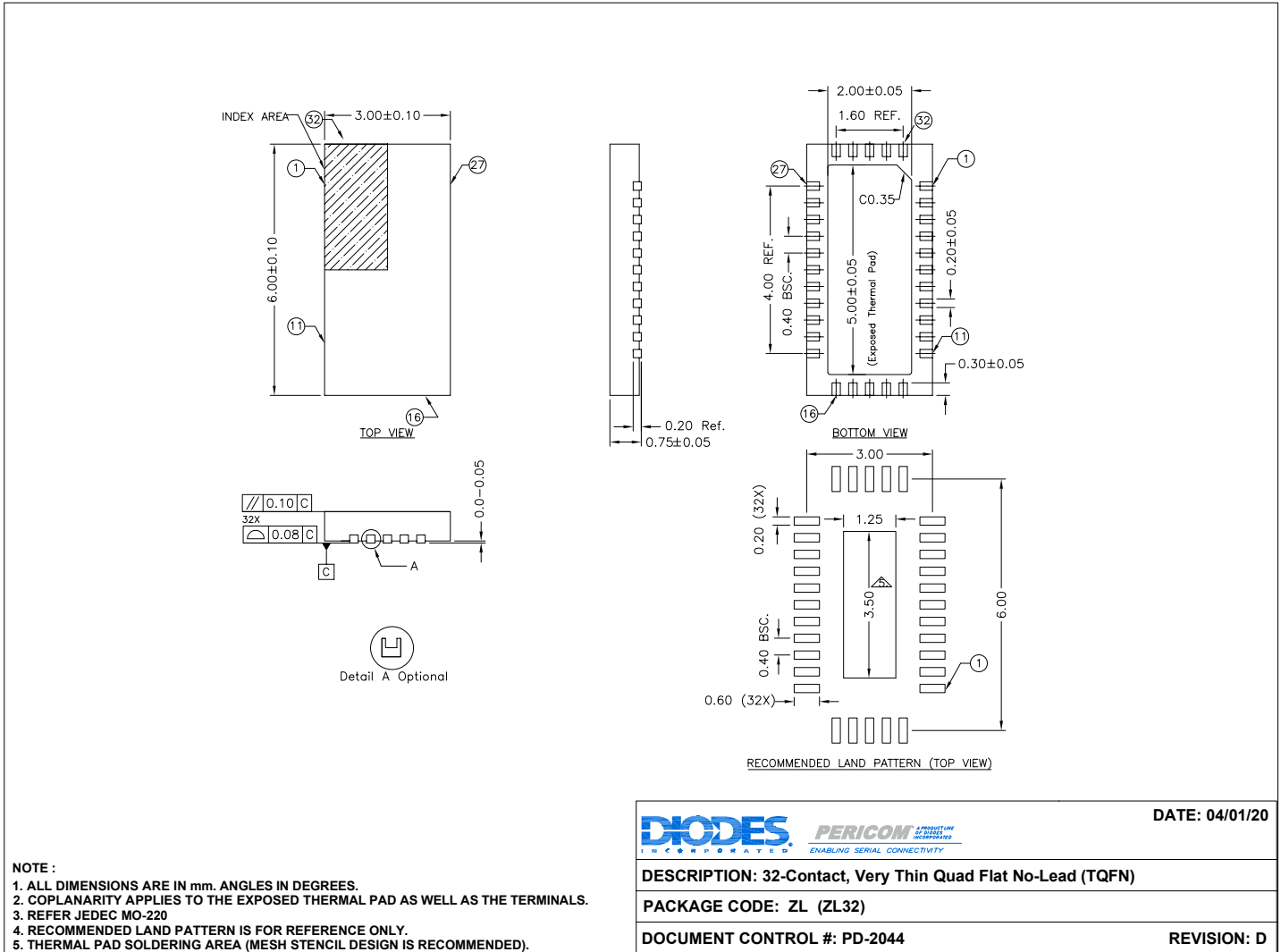

20-1240

Figure 8-1 32-pin TQFN package mechanical

PI3HDX1204E

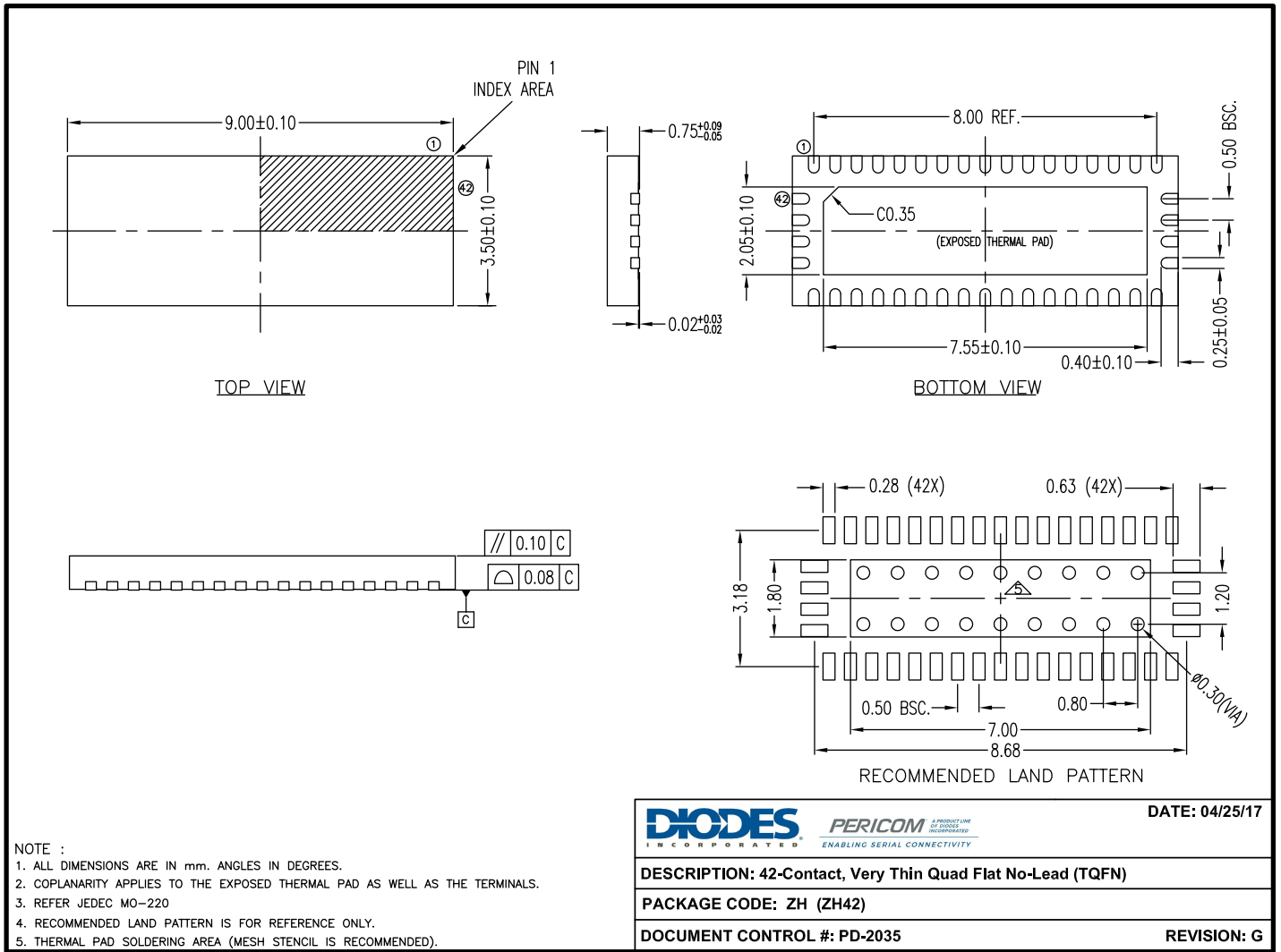

17-0266

Figure 8-2 42-pin TQFN package mechanical

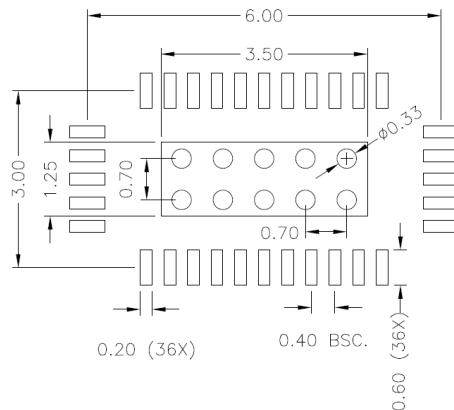

Figure 8-3 42-pin TQFN package mechanical

PI3HDX1204E

8.2 Part Marking Information

Our standard product mark follows our standard part number ordering information, except for those products with a speed letter code. The speed letter code mark is placed after the package code letter, rather than after the device number as it is ordered. After electrical test screening and speed binning has been completed, we then perform an “add mark” operation which places the speed code letter at the end of the complete part number.

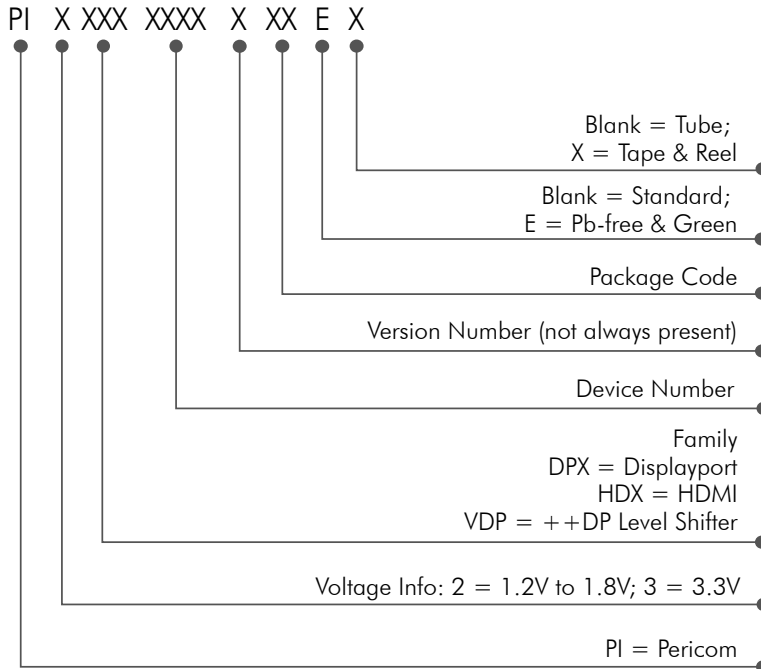
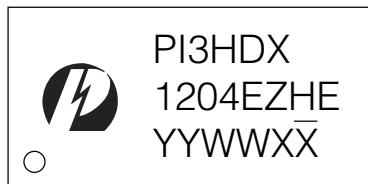

Figure 8-4 Part Numbers Information



YY: Year
WW: Workweek
1st X: Assembly Code
2nd X: Fab Code

Figure 8-5 Part Marking Information

8.3 Tape & Reel Materials and Design

8.3.1 Carrier Tape

The Pocketed Carrier Tape is made of Conductive Polystyrene plus Carbon material (or equivalent). The surface resistivity is 10^6 Ohm/sq. maximum. Pocket tapes are designed so that the component remains in position for automatic handling after cover tape is removed. Each pocket has a hole in the center for automated sensing if the pocket is occupied or not, thus facilitating device removal. Sprocket holes along the edge of the center tape enable direct feeding into automated board assembly equipment. See Figures 3 and 4 for carrier tape dimensions.

8.3.2 Cover Tape

Cover tape is made of Anti-static Transparent Polyester film. The surface resistivity is 10^7 Ohm/Sq. Minimum to 10^{11} Ohm sq. maximum. The cover tape is heat-sealed to the edges of the carrier tape to encase the devices in the pockets. The force to peel back the cover tape from the carrier tape shall be a MEAN value of 20 to 80gm (2N to 0.8N).

8.3.3 Reel

The device loading orientation is in compliance with EIA-481, current version (Figure 2). The loaded carrier tape is wound onto either a 13-inch reel, (Figure 4) or 7-inch reel. The reel is made of Antistatic High-Impact Polystyrene. The surface resistivity 10^7 Ohm/sq. minimum to 10^{11} Ohm/sq. max.

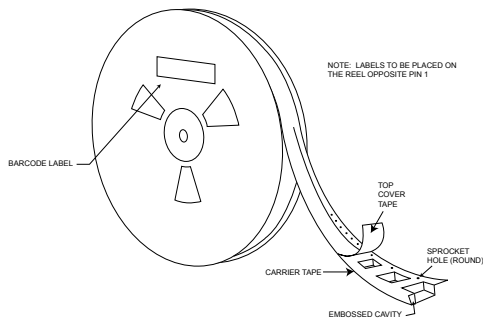

Figure 8-6 Tape & Reel Label Information

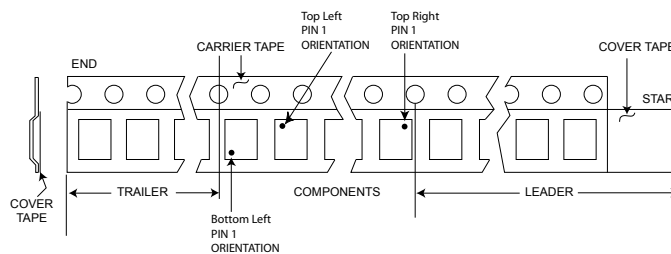

Figure 8-7 Tape Leader and Trailer pin 1 Orientations

PI3HDX1204E

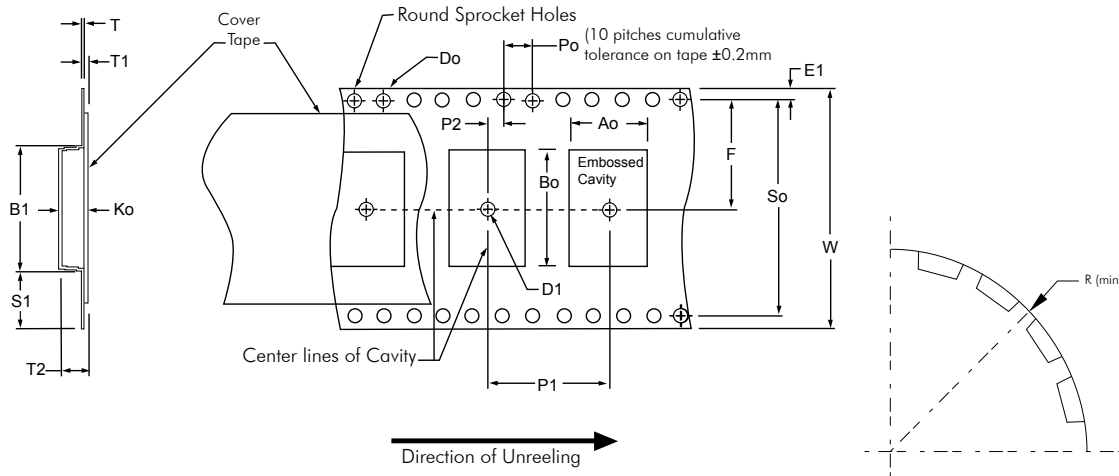

Figure 8-8 Standard Embossed Carrier Tape Dimensions

Table 8-1. Constant Dimensions

Tape Size	D0	D1 (Min)	E1	P0	P2	R (See Note 2)	S1 (Min)	T (Max)	T1 (Max)	
8mm	1.5 +0.1 -0.0	1.0	1.75 ± 0.1	4.0 ± 0.1	2.0 ± 0.05	25	0.6	0.6	0.1	
12mm		1.5				2.0 ± 0.1				30
16mm					2.0					2.0 ± 0.1
24mm		2.0 ± 0.1				50	N/A (See Note 3)			
32mm										
44mm		2.0 ± 0.15			50	N/A (See Note 3)				

Table 8-2. Variable Dimensions

Tape Size	P1	B1 (Max)	E2 (Min)	F	So	T2 (Max.)	W (Max)	A0, B0, & K0
8mm	Specific per package type. Refer to FR-0221 (Tape and Reel Packing Information)	4.35	6.25	3.5 ± 0.05	N/A (see note 4)	2.5	8.3	See Note 1
12mm		8.2	10.25	5.5 ± 0.05		6.5	12.3	
16mm		12.1	14.25	7.5 ± 0.1		8.0	16.3	
24mm		20.1	22.25	11.5 ± 0.1	12.0	24.3		
32mm		23.0	N/A	14.2 ± 0.1		28.4 ± 0.1	32.3	
44mm		35.0	N/A	20.2 ± 0.15	40.4 ± 0.1	16.0	44.3	

NOTES:

- A0, B0, and K0 are determined by component size. The cavity must restrict lateral movement of component to 0.5mm maximum for 8mm and 12mm wide tape and to 1.0mm maximum for 16,24,32, and 44mm wide carrier. The maximum component rotation within the cavity must be limited to 20o maximum for 8 and 12 mm carrier tapes and 10o maximum for 16 through 44mm.
- Tape and components will pass around reel with radius "R" without damage.
- S1 does not apply to carrier width ≥32mm because carrier has sprocket holes on both sides of carrier where Do ≥ S1.
- So does not exist for carrier ≤32mm because carrier does not have sprocket hole on both side of carrier.

PI3HDX1204E

Table 8-3. Reel Dimensions by Tape Size

Tape Size	A	N (Min) See Note A	W1	W2 (Max)	W3	B (Min)	C	D (Min)
8mm	178 ±2.0mm or 330±2.0mm	60 ±2.0mm or 100±2.0mm	8.4 +1.5/-0.0 mm	14.4 mm	Shall Ac- com- date Tape Width Without Interfer- ence	1.5mm	13.0 +0.5/- 0.2 mm	20.2mm
12mm			12.4 +2.0/-0.0 mm	18.4 mm				
16mm	330 ±2.0mm	100 ±2.0mm	16.4 +2.0/-0.0 mm	22.4 mm				
24mm			24.4 +2.0/-0.0 mm	30.4 mm				
32mm			32.4 +2.0/-0.0 mm	38.4 mm				
44mm			44.4 +2.0/-0.0 mm	50.4 mm				

NOTE:

A. If reel diameter A=178 ±2.0mm, then the corresponding hub diameter (N(min)) will by 60 ±2.0mm. If reel diameter A=330±2.0mm, then the corresponding hub diameter (N(min)) will by 100±2.0mm.