

Ultra-High Voltage Protection USB2 1:2 Mux/DeMux

Features

- Differential Bi-Directional 2:1 Mux/DeMux
- Wide Input Voltage Range: 0-5.5V
- Wide bandwidth: 1GHz
 - ◆ Ultra-low Con: 7pF
 - ◆ Ultra-low Ron: 5Ω (typ)
- Low Propagation Delay, 0.25ns typ
- Low Off-Isolation, -30dB@240MHz
- Low Crosstalk: -35dB@240MHz,
- Low Power Consumption: 35μA typical
- Wide Supply Voltage 2.7-5.5V
- Support 1.8V Logic on Control Pins
- Protection Feature
 - ◆ Off-protection for current leakage in power-down mode
 - ◆ All I/O pins are high voltage tolerance
 - C0+/C0- tolerance to 18V
 - Lx+/- tolerance to 6V
 - V_{DD} tolerance to 9V
 - ◆ Over-voltage protection when Vbus short to C0-/C0+ when device is power-on and enabled
- ESD Protection on (C0+/-)
 - ◆ IEC61000-4-2
- Wide Temperature Range: -40°C to 85°C
- Totally Lead-Free & Fully RoHS Compliant (Notes 1 & 2)
- Halogen and Antimony Free. “Green” Device (Note 3)
- Packaging (Pb-free & Green):
 - ◆ 10-contact, UQFN (ZUA10), 1.5x2mm, 0.5mm(H), 0.6mm pitch
 - ◆ 10-contact, UQFN (ZM10), 1.4x1.8mm, 0.55mm(H), 0.4mm pitch

Description

The PI3USB4000A is a 2-to-1 differential channel multiplexer/demultiplexer switch. C0+/C0- pins can tolerate voltages up to 18V. Over-voltage protection (OVP) is implemented at 4.75V to immediately switch off the channels when over-voltage condition is detected. PI3USB4000A can pass USB2.0 signal with bandwidth 1GHz to maintain signal integrity and eye diagram open.

Applications

- Smart Phone, type-c application, Tablets, NB, PC

Block Diagram

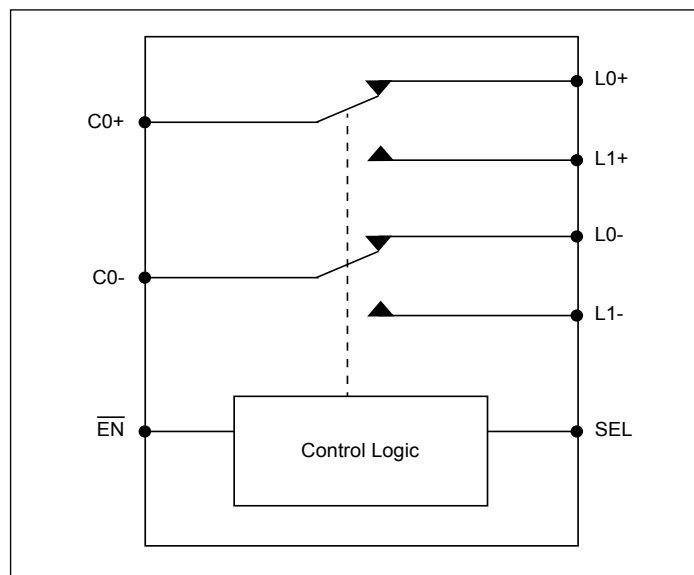

Notes:

1. No purposely added lead. Fully EU Directive 2002/95/EC (RoHS), 2011/65/EU (RoHS 2) & 2015/863/EU (RoHS 3) compliant.
2. See <https://www.diodes.com/quality/lead-free/> for more information about Diodes Incorporated’s definitions of Halogen- and Antimony-free, “Green” and Lead-free.
3. Halogen- and Antimony-free “Green” products are defined as those which contain <900ppm bromine, <900ppm chlorine (<1500ppm total Br + Cl) and <1000ppm antimony compounds.

Pin Configuration

10-UQFN Pin# (ZUA10), Top View

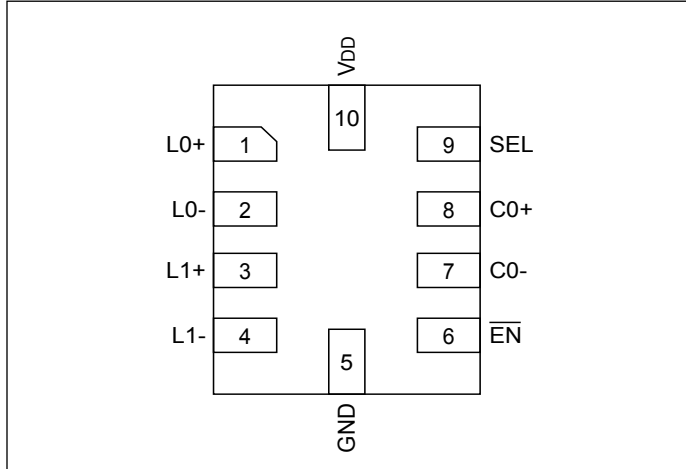

10-UQFN Pin# (ZM10), Top View

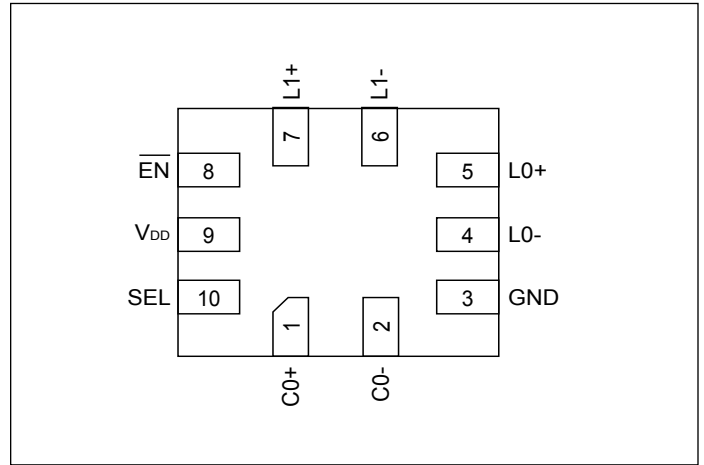

Pin Description

10-UQFN Pin# (ZUA10)	10-UQFN Pin# (ZM10)	Pin Name	Signal Type	Description
8, 7	1, 2	C0+, C0-	I/O	Signal I/O, Common Port
3, 4	7, 8	L1+, L1-	I/O	Signal I/O, Channel 1
1, 2	5, 4	L0+, L0-	I/O	Signal I/O, Channel 0
9	10	SEL	I	Operation mode Select (when SEL=0: C0→L0, when SEL=1: C0→L1)
6	8	$\overline{\text{EN}}$	I	$\overline{\text{EN}} = 1$, Power down is enabled. Please see Truth Table.
10	9	VDD	Pwr	Positive Supply Voltage
5	3	GND	Pwr	Power ground

Truth Table

Function	SEL	$\overline{\text{EN}}$
C0+/- to L0+/-	L	L
C0+/- to L1+/-	H	L
All Switches Hi-z	x	H

PI3USB4000A

PI3USB4000A application in MHL Switching and provide overvoltage protection for D+/- when high voltage charging

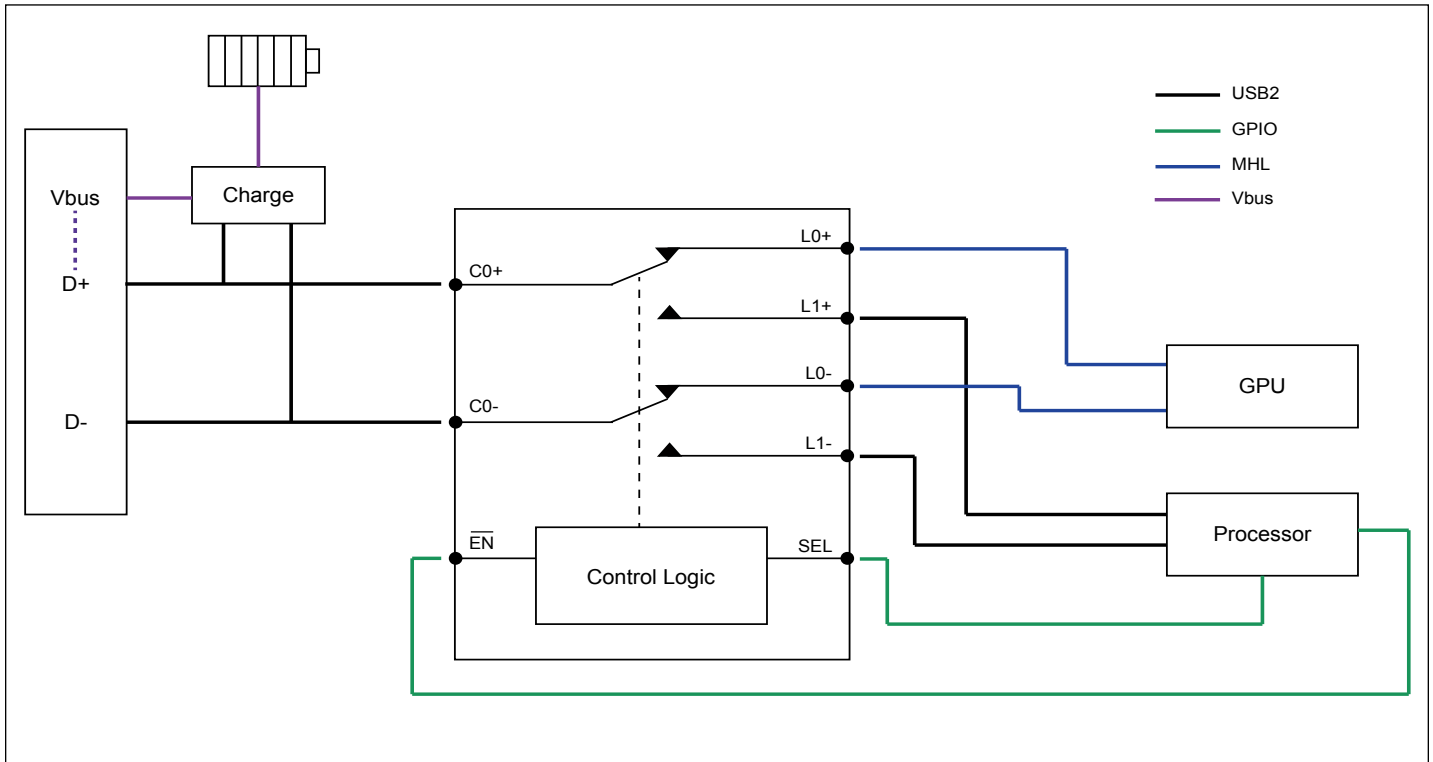

Maximum Ratings

(Above which useful life may be impaired. For user guidelines, not tested.)

Storage Temperature	-65°C to +150°C
Supply Voltage (VDD) to Ground Potential	-0.3V to +9V
Channel Input/Output Voltage (Lx+/-)	-0.3V to +6V
Channel Input/Output Voltage (C0+/-)	-0.3V to +18V
Control Pins Input Voltage (EN/SEL)	-0.3V to +6V
ESD (All Pins).....	2KV (HBM) and 1KV (CDM)
Channel Input/Output Current (Lx/C0).....	±50mA
Junction Temperature.....	125°C

Note:

Stresses greater than those listed under MAXIMUM RATINGS may cause permanent damage to the device. This is a stress rating only and functional operation of the device at these or any other conditions above those indicated in the operational sections of this specification is not implied. Exposure to absolute maximum rating conditions for extended periods may affect reliability.

Recommended Operating Conditions

Symbol	Description	Test Conditions	Min.	Typ.	Max.	Units
V _{DD}	Power Supply		2.7	3.3	6.0	V
V _{IO}	Analog Voltage Range		0		5.5	V
V _I	Voltage Range for Control Pins		0		5.5	V
I _{DD}	Current Consumption in Normal Operation	V _{DD} = 3.3V, V _{IO} = 0V, SEL = GND or V _{DD} , EN = Low		35	45	μA
I _{DD_OVP}	Current Consumption in OVP	V _{DD} = 3.3V, V _{C0+} /V _{C0-} = 5.5V, SEL = GND or V _{DD} , EN = Low		35		μA
I _{DDQ}	Chip Disabled Current Consumption	V _{DD} = 3.3V, V _{IO} = 0V, SEL = GND or V _{DD} , EN = High		1	2	μA
T _A	Operating Temperature Range		-40		85	°C

DC Electrical Characteristics for Switching over Operating Range

(T_A = -40°C to 85°C, Typical values are at V_{DD} = 3.3V, T_A = 25°C, (unless otherwise noted))

Parameter	Description	Test Conditions	Min.	Typ.	Max.	Units
Control Pins - EN/SEL						
V _{IH} - cntrl signals	Input HIGH Voltage for SEL and EN	V _{DD} = 2.7-5.5V	1.2			V
V _{IL} - cntrl signals	Input LOW Voltage for SEL and EN	V _{DD} = 2.7-5.5V			0.6	V
I _{IH}	Input HIGH Current for SEL and EN	V _I = 0-5.5V	-1		1	μA
I _{IL}	Input LOW Current for SEL and EN	V _I = 0-5.5V	-1		1	μA
High Speed IO - L0/L1/C0						
V _{OVP}	OVP trigger voltage		4.6	4.75	5.0	V
R _{on}	ON resistance	V _{I/O} = 0V, 0.4V, I _{on} = -8 mA		5	8	Ω
Δ R _{on}	On resistance between + and - channel	V _{I/O} = 0V, 0.4V, I _{on} = -8 mA		0.5	1	Ω
R _{on_Flat}	ON resistance flatness	V _{I/O} = 0V, 0.4V, I _{on} = -8 mA		0.2	0.5	Ω
I _{off}	Power-off leakage	V _{DD} = 0V, V _{I/O} = 0 - 3.6V	-1		1	μA
I _{OC}	Channel off leakage current	EN = V _{DD} = 3.3V, V _{I/O} = 0-3.6V	-1		1	μA
I _{ON}	Channel on leakage current	EN = 0V, V _{DD} = 3.3V, V _{I/O} = 0-3.6V	-1		1	μA
I _{OVP}	Leakage current on C0+/C0- in OVP mode	EN = 0V, V _{DD} = 3.3V, V _{C0+} or V _{C0-} = 14V		3	15	μA

Dynamic Electrical Characteristics

($T_A = -40^{\circ}\text{C}$ to 85°C , Typical values are at $V_{DD} = 3.3\text{V}$, $T_A = 25^{\circ}\text{C}$, (unless otherwise noted))

Parameter	Description	Test Conditions	Min.	Typ.	Max.	Units
Control Pins – EN/SEL						
C_I	Input capacitance	$f=1\text{MHz}$		5		pF
High Speed IO – L0/L1/C0						
Con	ON Capacitance	$f=1\text{MHz}$		7		pF
Coff	OFF Capacitance	$f=1\text{MHz}$		9		pF
DDIL	Insertion Loss	$f=240\text{MHz}$		-0.5		dB
DDRL	Differential Return Loss	$f=240\text{MHz}$		-15		dB
DDOI	Differential OFF Isolation	$f=240\text{MHz}$		-30		dB
		$f=100\text{kHz}$		-80		dB
DDXT	Differential Crosstalk	$f=240\text{MHz}$		-35		dB
BW	-3dB Bandwidth			1		GHz

Switching Characteristics⁽¹⁾

($T_A = -40^{\circ}\text{C}$ to 85°C , Typical values are at $V_{DD} = 3.3\text{V}$, $T_A = 25^{\circ}\text{C}$, (unless otherwise noted))

Parameter	Description	Test Conditions	Min.	Typ.	Max.	Units
t_{OVP}	OVP Response Time ⁽¹⁾	$R_{LX} = 600\Omega$, time from the voltage on $C0_{\pm} = 4\sim 6\text{V}$ to the voltage on $LX_{\pm} = 4.75$		0.5	1	μs
t_{PZH}, t_{PZL}	Line Enable Time	See Test Circuit for Electrical Characteristics		20		μs
t_{PHZ}, t_{PLZ}	Line Disable Time			50		ns
t_{pd}	Propagation Delay			250		ps
t_{b-b}	Bit-to-bit Skew Within the Same Differential Pair ⁽¹⁾			8	20	ps
T_{on}	Device Enable Time			100		μs
T_{off}	Device Disable Time			50		ns

Note:

1. Guaranteed by design.

PI3USB4000A

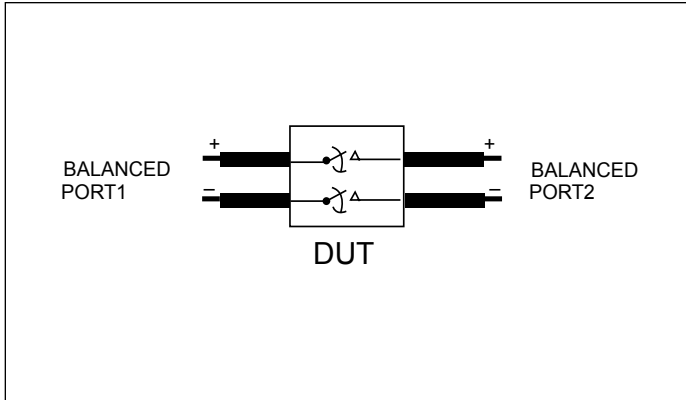

Fig 1. Differential Insertion Loss Setup

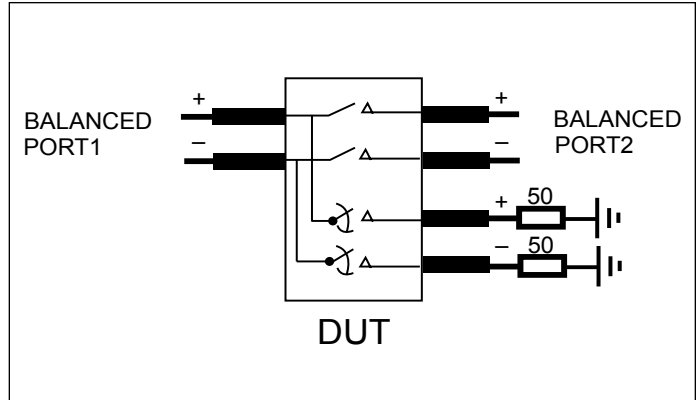

Fig 2. Off-isolation Setup

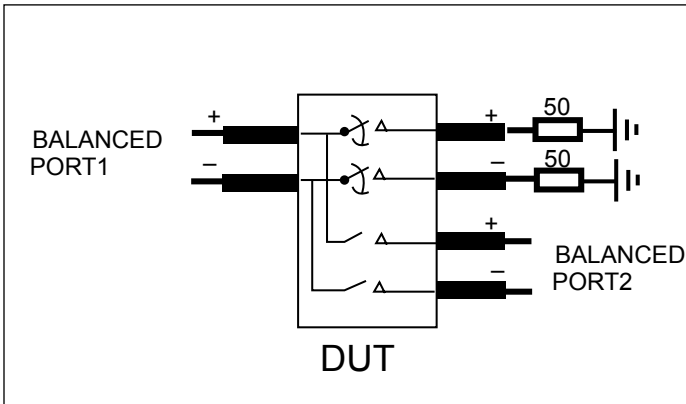

Fig 3. Crosstalk Setup

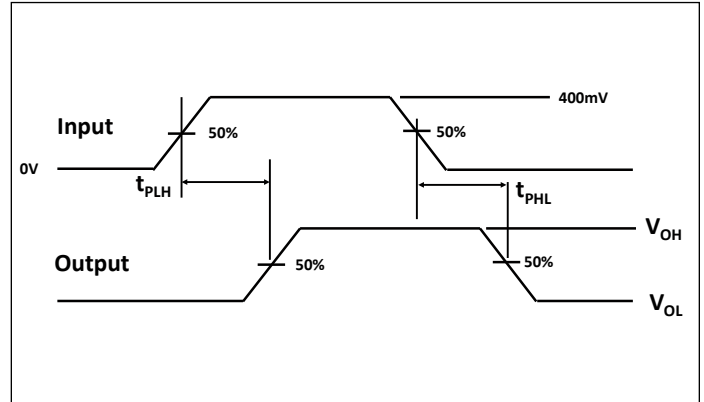

Fig 4. Propagation Delay

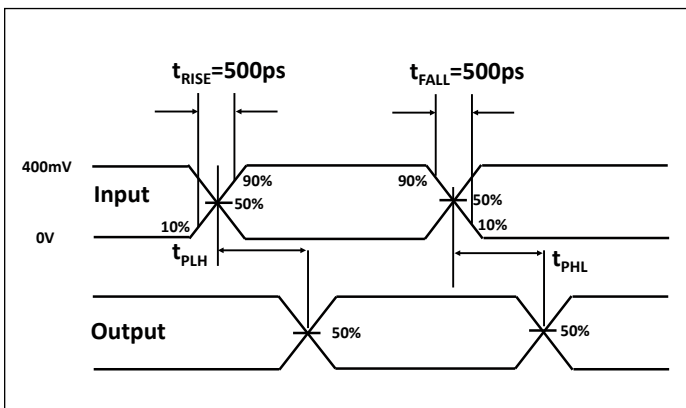
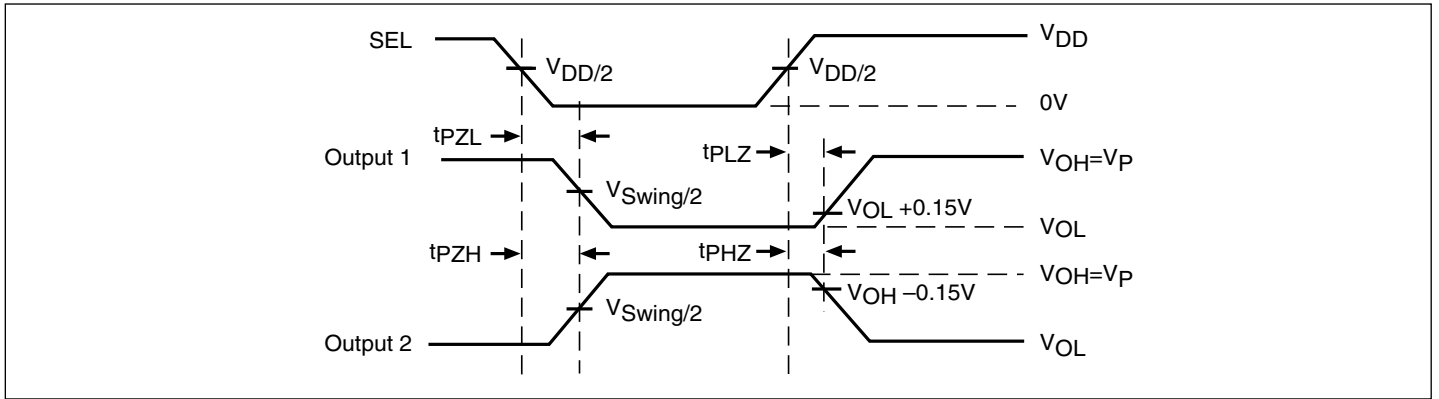

Fig 5. Skew Test

Switching Waveforms



Voltage Waveforms Enable and Disable Times

Test Circuit for Propagation Delay

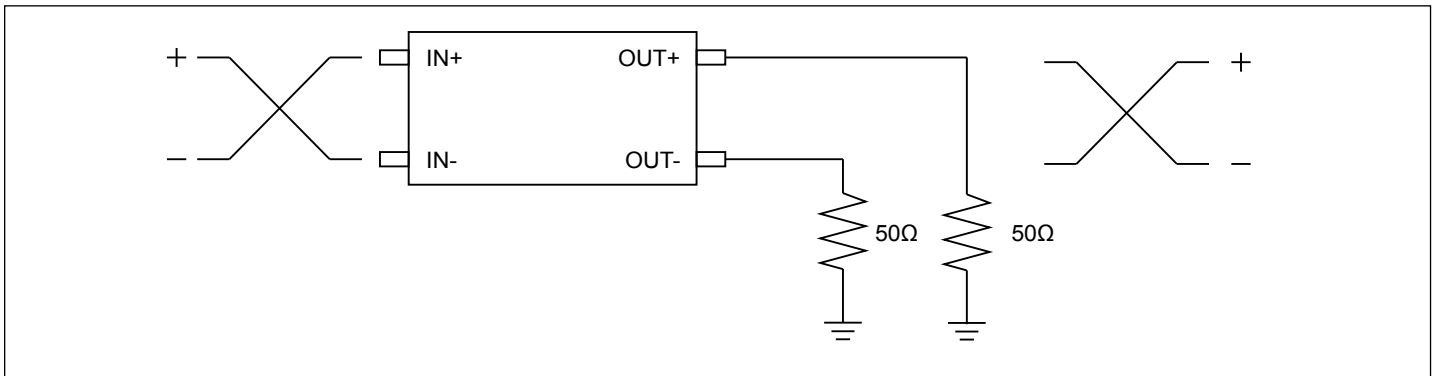

Part Marking

ZM and ZUA Package

DF: PI3USB4000A

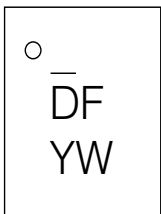

Y: Year

W: Workweek

PI3USB4000A

Packaging Mechanical: 10-UQFN (ZUA)

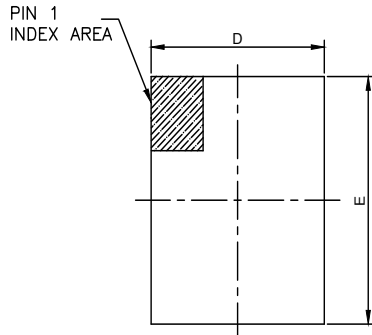

TOP VIEW

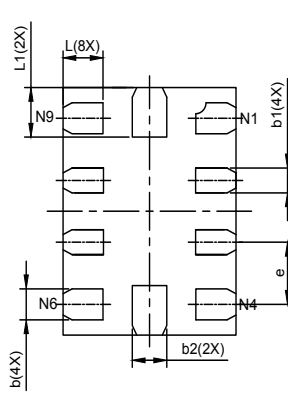

BOTTOM VIEW

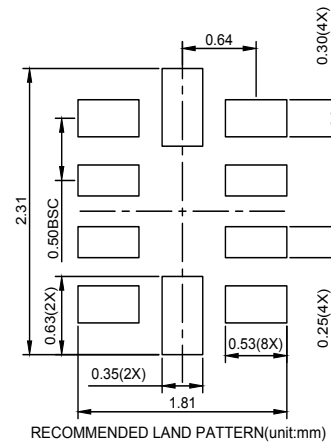

RECOMMENDED LAND PATTERN(unit:mm)

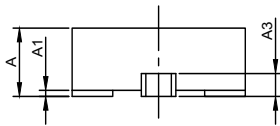

SIDE VIEW

PKG. DIMENSIONS(MM)			
SYMBOL	Min	NOM	Max
A	0.50	0.60	0.65
A1	0.00	0.02	0.05
A3	0.15 REF		
D	1.45	1.50	1.55
E	1.95	2.00	2.05
b	0.20	0.25	0.30
b1	0.15	0.20	0.25
b2	0.25	0.30	0.35
e	0.50 BSC		
L	0.25	0.35	0.45
L1	0.30	0.40	0.50

Notes:

1. Ref: JEDEC MO-288B.

DESCRIPTION: 10-Pin, UQFN, 1.5X2.0

PACKAGE CODE: ZUA(ZUA10)

DOCUMENT CONTROL#: PD-2220

REVISION: --

Packaging Mechanical: 10-UQFN (ZM)

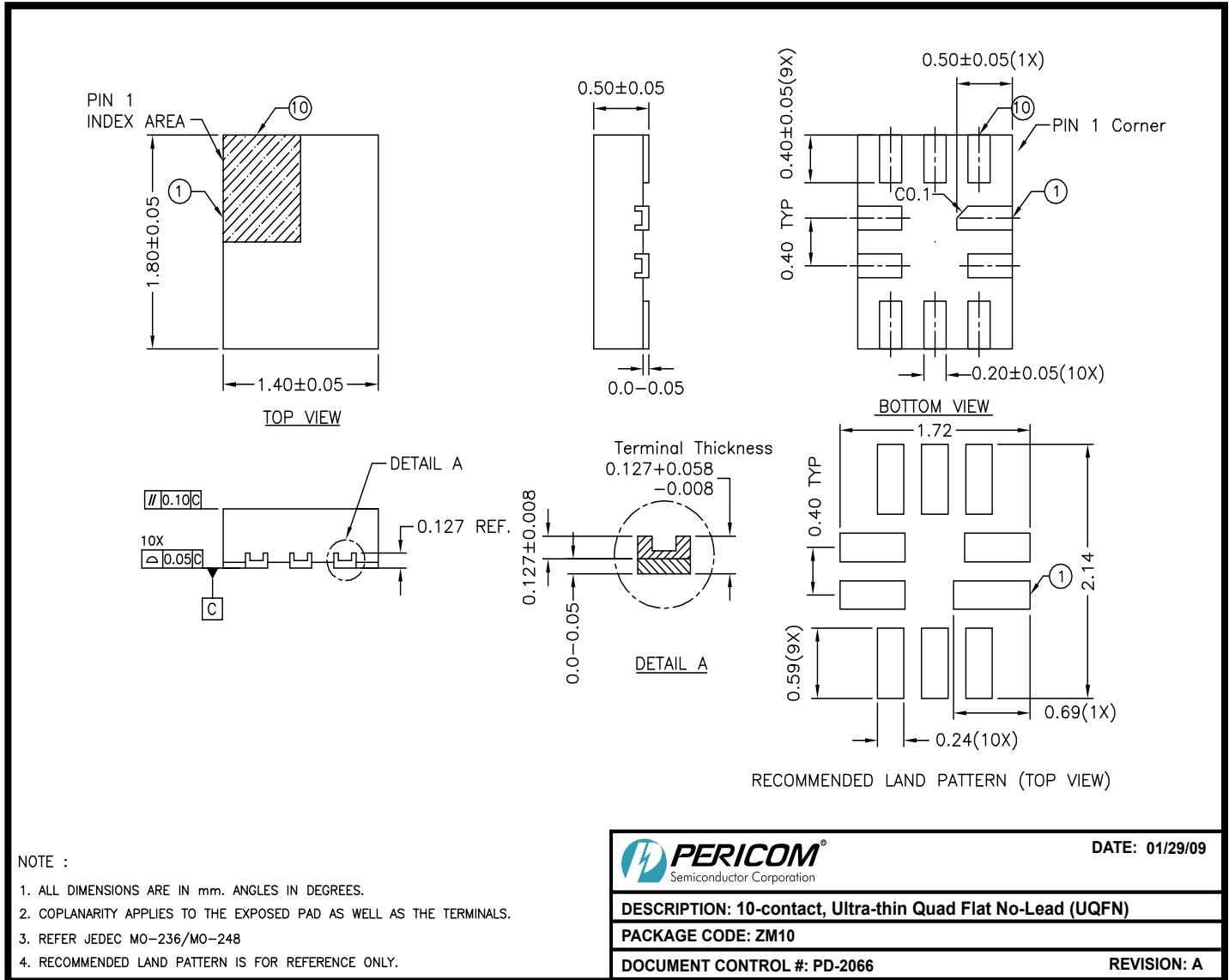

09-0072

For latest package info.

please check: <http://www.diodes.com/design/support/packaging/pericom-packaging/packaging-mechanicals-and-thermal-characteristics/>

Ordering Information

Ordering Code	Package Code	Package Description
PI3USB4000AZUAEX	ZUA	10-Pin, 1.5x2.0 (UQFN)
PI3USB4000AZMEX	ZM	10-contact, Ultra-thin Quad Flat No-Lead (UQFN)

Notes:

- No purposely added lead. Fully EU Directive 2002/95/EC (RoHS), 2011/65/EU (RoHS 2) & 2015/863/EU (RoHS 3) compliant.
- See <https://www.diodes.com/quality/lead-free/> for more information about Diodes Incorporated's definitions of Halogen- and Antimony-free, "Green" and Lead-free.
- Halogen- and Antimony-free "Green" products are defined as those which contain <900ppm bromine, <900ppm chlorine (<1500ppm total Br + Cl) and <1000ppm antimony compounds.
- E = Pb-free and Green
- X suffix = Tape/Reel