

Ultra-High Voltage Protection USB2 1:2 Mux/DeMux

Features

- Differential Bi-directional 2:1 Mux/DeMux
- Wide Input Voltage Range: 0 to 5.5V
- Wide bandwidth: 1GHz
- Ultra-low Con: 7pF
- Ultra-low Ron: 5Ω (typ)
- Low Propagation Delay, 0.25ns typ
- Low Off-Isolation, -30dB@240MHz
- Low Crosstalk: -35dB@240MHz,
- Low Power Consumption: 35μA typical
- Wide Supply Voltage 2.7 to 5.5V
- Support 1.8V Logic on Control Pins
- Protection Feature
 - ◆ Off-protection for current leakage in power-down mode
 - ◆ All I/O pins are high voltage tolerance
 - C0+/C0- tolerance to 24V
 - Lx+/- tolerance to 6V
 - V_{DD} tolerance to 6V
 - ◆ Over-voltage protection when Vbus short to C0-/C0+ when device is power-on and enabled
- ESD Protection on (C0+/-)
 - ◆ IEC61000-4-2, 10kV
- Wide Temperature Range: -40°C to 85°C
- Totally Lead-Free & Fully RoHS Compliant (Notes 1 & 2)
- Halogen and Antimony Free. “Green” Device (Note 3)
- For automotive applications requiring specific change control (i.e. parts qualified to AEC-Q100/101/200, PPAP capable, and manufactured in IATF 16949 certified facilities), please [contact us](mailto:contact@diodes.com) or your local Diodes representative.
<https://www.diodes.com/quality/product-definitions/>
- Packaging (Pb-free & Green):
 - ◆ 10-contact, UQFN (ZUA), 1.5x2mm, 0.5mm(H), 0.6mm pitch

Description

The PI3USB4000D is a 2-to-1 differential channel multiplexer/demultiplexer switch. C0+/C0- pins can tolerate voltages up to 24V. Over-voltage protection (OVP) is implemented at 4.75V to immediately switch off the channels when over-voltage condition is detected. PI3USB4000D can pass USB2.0 signal with bandwidth 1GHz to maintain signal integrity and eye diagram open.

Applications

- Smart Phone, USB-C application, Tablets, NB, PC

Block Diagram

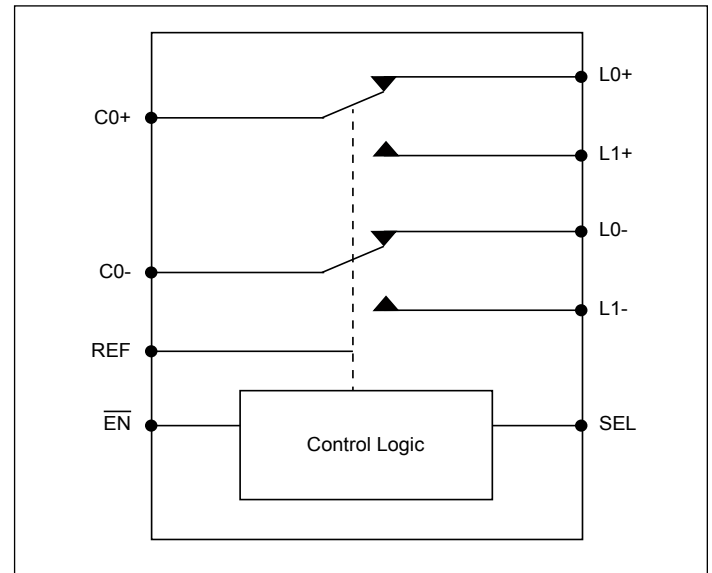

Notes:

1. No purposely added lead. Fully EU Directive 2002/95/EC (RoHS), 2011/65/EU (RoHS 2) & 2015/863/EU (RoHS 3) compliant.
2. See <https://www.diodes.com/quality/lead-free/> for more information about Diodes Incorporated’s definitions of Halogen- and Antimony-free, “Green” and Lead-free.
3. Halogen- and Antimony-free “Green” products are defined as those which contain <900ppm bromine, <900ppm chlorine (<1500ppm total Br + Cl) and <1000ppm antimony compounds.

Pin Configuration

Top View

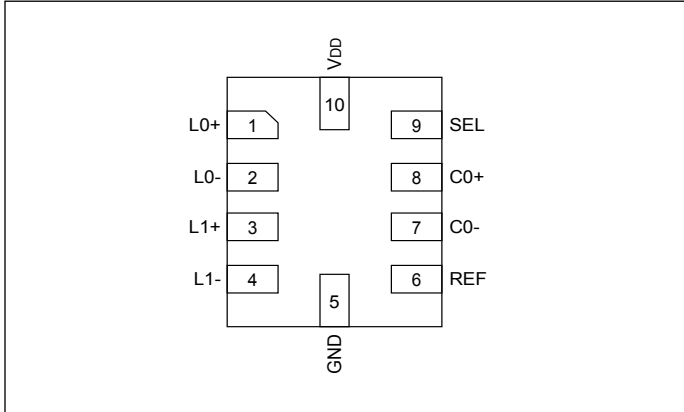

Pin Description

Pin#	Pin Name	Signal Type	Description
8, 7	C0+, C0-	I/O	Signal I/O, Common Port
3, 4	L1+, L1-	I/O	Signal I/O, Channel 1
1, 2	L0+, L0-	I/O	Signal I/O, Channel 0
9	SEL	I	Operation mode Select (when SEL=0: C0→L0, when SEL=1: C0→L1)
6	REF	PWR	Reference pin, tie to GND through cap*
10	V _{DD}	PWR	Positive Supply Voltage
5	GND	PWR	Power ground
-	$\overline{\text{EN}}$	I	$\overline{\text{EN}} = 1$, Power down is enabled. Please see Truth Table.
-	NC	NC	Not Connect

* The Cap on the REF pin required 1uF and 25V tolerance

Truth Table

Function	SEL
C0+/- to L0+/-	L
C0+/- to L1+/-	H

PI3USB4000D application in MHL Switching and provide overvoltage protection for D+/- when high voltage charging

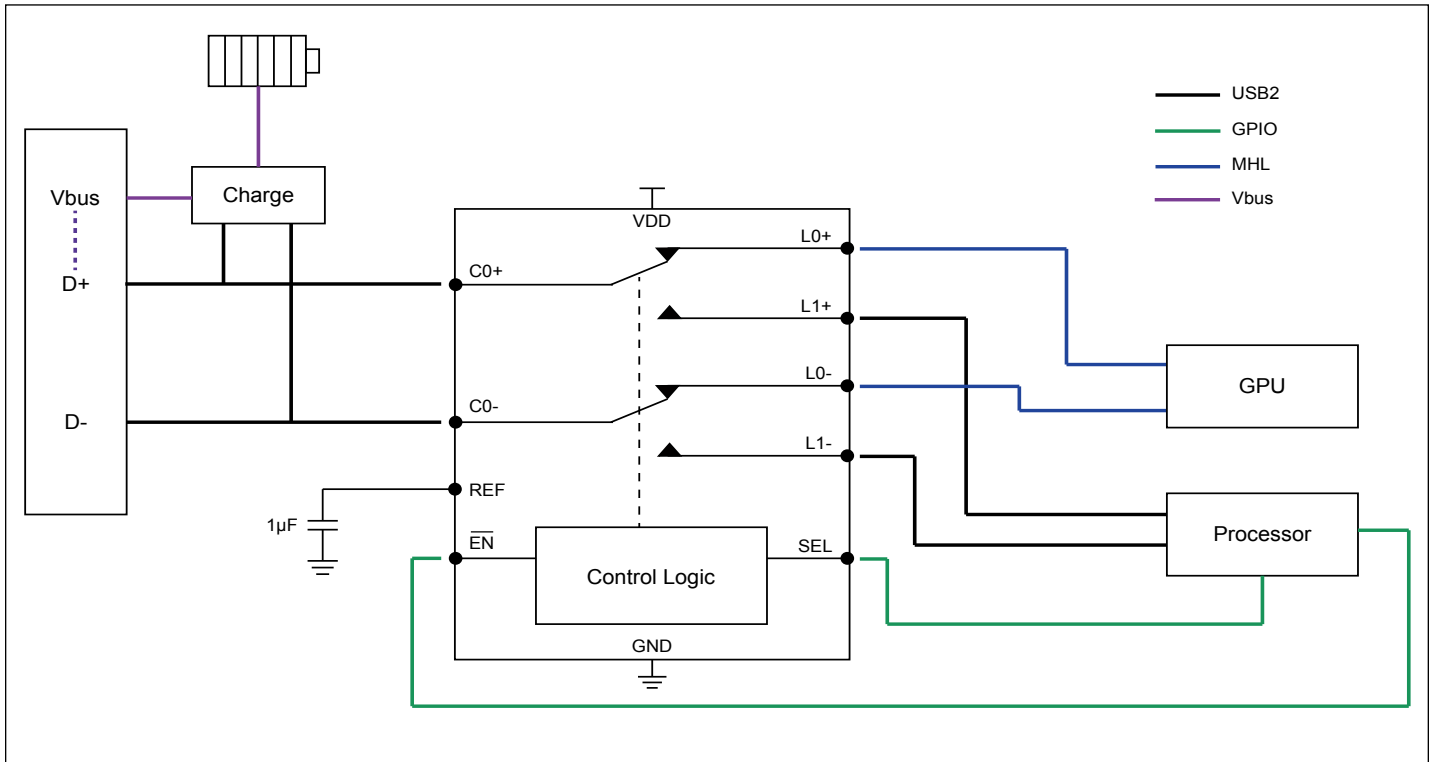

Note:

The capacitor connected to REF pin should have rated voltage higher than maximum voltage applied to C0+/- pins; the max rating of device on C0+/- is 24V, customer can select lower voltage capacitor if system required lower voltage tolerance on C0+/-; capacitance of 1uF.

1. The 1uF capacitor recommend to be placed to the REF and GND pin of the device as close as possible
2. The decoupling capacitor at the VDD recommend to be placed to the device as close as possible.
3. Keep the trace between connector and device as long as possible; if needs inductor between device and connector, it recommend to be placed to the USB connector as close as possible and leaving some trace line between the device and the inductor would help some for the ESD performance.

USB2.0 High Speed (480Mbps) Eye Diagram

No Device (Trace Only)

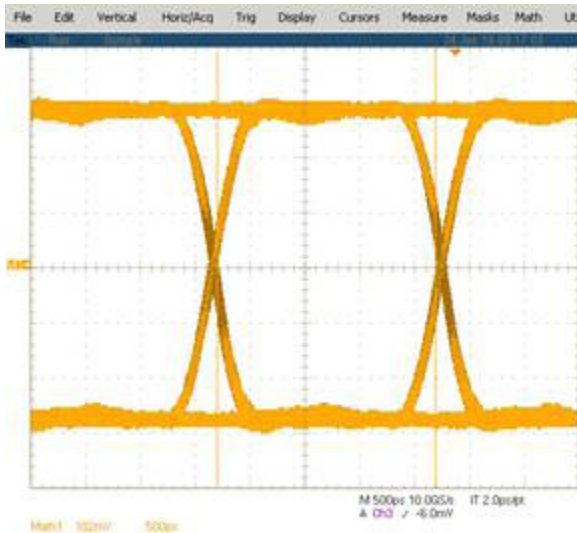

With USB4000D

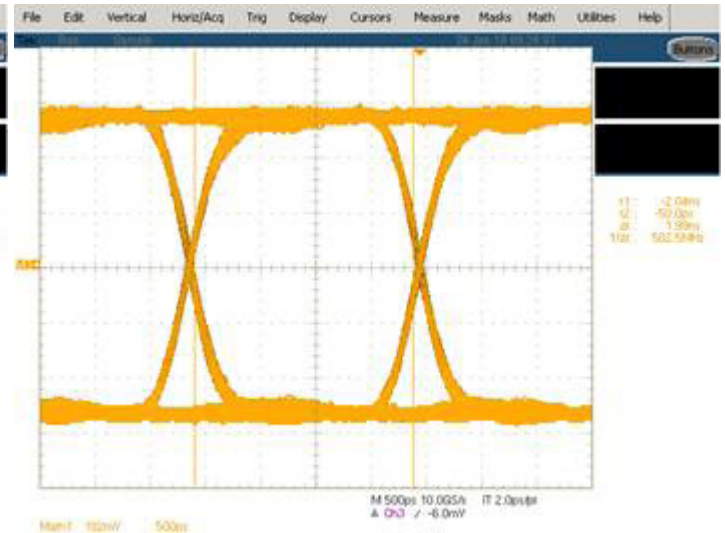

Maximum Ratings

(Above which useful life may be impaired. For user guidelines, not tested.)

Storage Temperature	-65°C to +150°C
Supply Voltage (VDD) to Ground Potential	-0.3V to +6V
Channel Input/Output Voltage (Lx+/-)	-0.3V to +6V
Channel Input/Output Voltage (C0+/-)	-0.3V to +24V
Reference Pin Voltage (REF) to Ground Potential.....	-0.3V to +24V
Control Pins Input Voltage ($\overline{\text{EN/SEL}}$)	-0.3V to +6V
ESD (All Pins).....	2KV (HBM) and 1KV (CDM)
Channel Input/Output Current (Lx/C0).....	±50mA

Note:

Stresses greater than those listed under MAXIMUM RATINGS may cause permanent damage to the device. This is a stress rating only and functional operation of the device at these or any other conditions above those indicated in the operational sections of this specification is not implied. Exposure to absolute maximum rating conditions for extended periods may affect reliability.

Recommended Operating Conditions

Symbol	Description	Test Conditions	Min.	Typ.	Max.	Units
V _{DD}	Power Supply		2.7	3.3	5.5	V
V _{I/O}	Analog Voltage Range		0		5.5	V
V _I	Voltage Range for Control Pins		0		5.5	V
I _{DD}	Current Consumption in Normal Operation	V _{DD} = 3.3V, V _{IO} = 0V, SEL = GND or V _{DD} , chip enabled		35	45	μA
I _{DD_OVP}	Current Consumption in OVP	V _{DD} = 3.3V, V _{CO+} /V _{CO-} = 5.5V, SEL = GND or V _{DD} , chip enabled		35		μA
I _{DDQ}	Chip Disabled Current Consumption	V _{DD} = 3.3V, V _{IO} = 0V, SEL = GND or V _{DD} , $\overline{\text{EN}}$ = High		1	2	μA
T _A	Operating Temperature Range		-40		85	°C

DC Electrical Characteristics for Switching over Operating Range

(T_A = -40°C to 85°C, Typical values are at V_{DD} = 3.3V, T_A = 25°C, $\overline{\text{EN}}$ = 0V, REF = NC (unless otherwise noted))

Parameter	Description	Test Conditions	Min.	Typ.	Max.	Units
Control Pins - $\overline{\text{EN/SEL}}$						
V _{IH} - cntrl signals	Input HIGH Voltage for SEL and $\overline{\text{EN}}$	V _{DD} = 2.7-5.5V	1.2			V
V _{IL} - cntrl signals	Input LOW Voltage for SEL and $\overline{\text{EN}}$	V _{DD} = 2.7-5.5V			0.6	V
I _{IH}	Input HIGH Current for SEL and $\overline{\text{EN}}$	V _I = 5.5V	-1		1	μA
I _{IL}	Input LOW Current for SEL and $\overline{\text{EN}}$	V _I = 0V	-1		1	μA
High Speed IO - L0/L1/C0						
V _{OVP}	CO± OVP trigger voltage		4.6	4.75	5.0	V
R _{on}	ON resistance	V _{I/O} = 0V, 0.4V, I _{on} = -8 mA		5	9	Ω
Δ R _{on}	On resistance between + and - channel	V _{I/O} = 0V, 0.4V, I _{on} = -8 mA		0.5	1	Ω
R _{on_Flat}	ON resistance flatness	V _{I/O} = 0V, 0.4V, I _{on} = -8 mA		0.2	0.5	Ω
I _{off}	CO± Power-off leakage	V _{DD} = 0V, V _{CO±} = 0-3.6V	-1		1	μA
I _{OC}	Channel off leakage current	V _{DD} = 3.3V, V _{Lx±} = 0-3.6V, channel is off	-1		1	μA
I _{ON}	Channel on leakage current	V _{DD} = 3.3V, V _{Lx±} = 0-3.6V, channel is on	-1		1	μA

DC Electrical Characteristics for Switching over Operating Range Cont.

Parameter	Description	Test Conditions	Min.	Typ.	Max.	Units
I _{OVP}	Leakage current on C0+/C0- in OVP mode	V _{DD} = 3.3V, V _{C0+} or V _{C0-} = 20V			1	mA
Z _{ON_GND}	On-State impedance to GND	SEL = H or L V _{I/O} = 0-3.6V	4	7		MΩ

Dynamic Electrical Characteristics

 (T_A = -40°C to 85°C, Typical values are at V_{DD} = 3.3V, T_A = 25°C, (unless otherwise noted))

Parameter	Description	Test Conditions	Min.	Typ.	Max.	Units
Control Pins – EN/SEL						
C _I	Input Capacitance	f=1MHz		5		pF
High Speed IO – L0/L1/C0						
C _{on}	ON Capacitance	f=1MHz		7		pF
C _{off}	OFF Capacitance	f=1MHz		9		pF
DDIL	Insertion Loss	f=240MHz		-0.5		dB
DDRL	Differential Return Loss	f=240MHz		-15		dB
DDOI	Differential OFF Isolation	f=240MHz		-30		dB
		f=100kHz		-80		dB
DDXT	Differential Crosstalk	f=240MHz		-35		dB
BW	-3dB Bandwidth			1		GHz

Switching Characteristics⁽¹⁾

 (T_A = -40°C to 85°C, Typical values are at V_{DD} = 3.3V, T_A = 25°C, (unless otherwise noted))

Parameter	Description	Test Conditions	Min.	Typ.	Max.	Units
t _{OVP}	OVP Response Time ⁽¹⁾	R _{LX} = 600Ω, time from the voltage on C0± = 4~6V to the voltage on L _X ± = 4.75V		0.5	1	μs
t _{PZH} , t _{PZL}	Line Enable Time	See Test Circuit for Electrical Characteristics		20		μs
t _{PHZ} , t _{PLZ}	Line Disable Time			50		ns
t _p d	Propagation Delay			250		ps
t _{b-b}	Bit-to-bit Skew Within the Same Differential Pair ⁽¹⁾			8	20	ps
T _{on}	Device Enable Time			100		μs
T _{off}	Device Disable Time			50		ns

Note:

1. Guaranteed by design.

PI3USB4000D

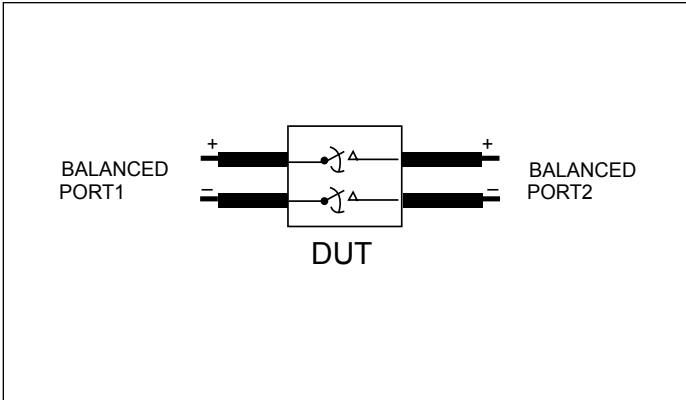

Fig 1. Differential Insertion Loss Setup

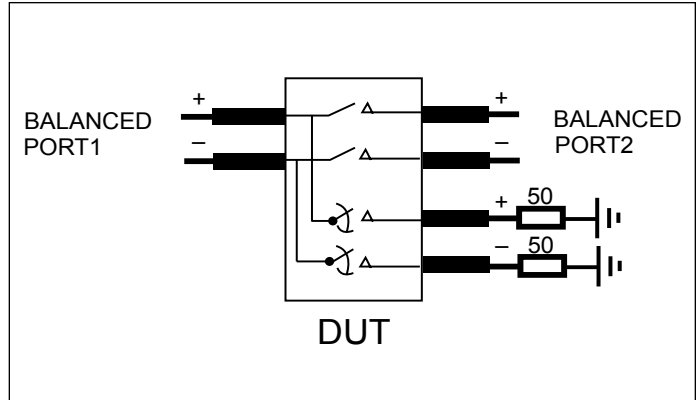

Fig 2. Off-isolation Setup

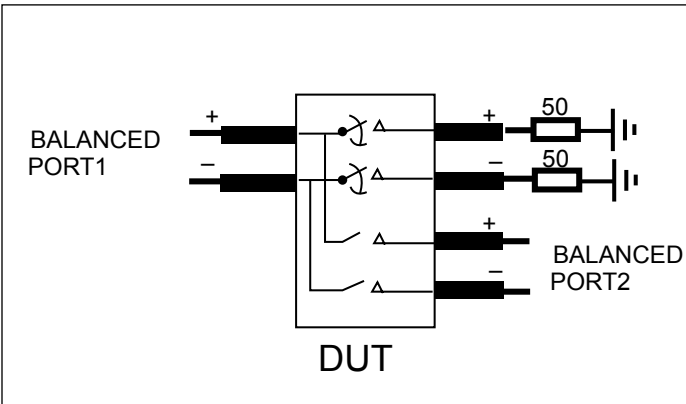

Fig 3. Crosstalk Setup

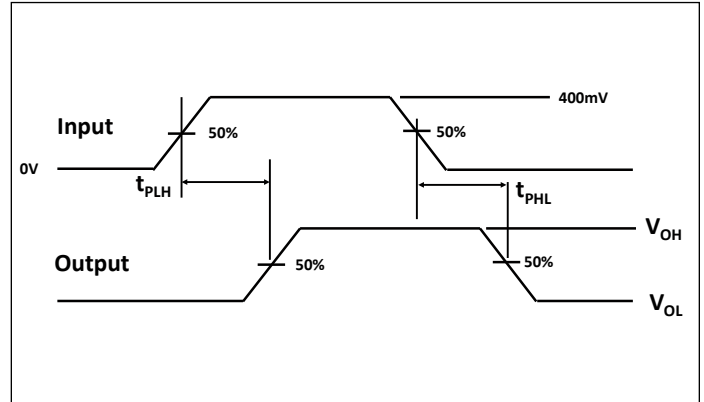

Fig 4. Propagation Delay

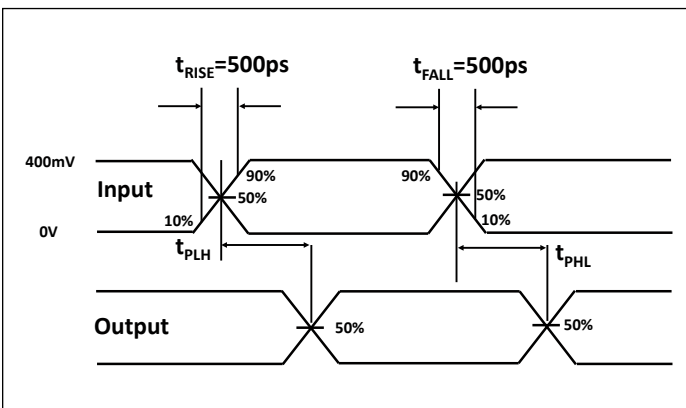
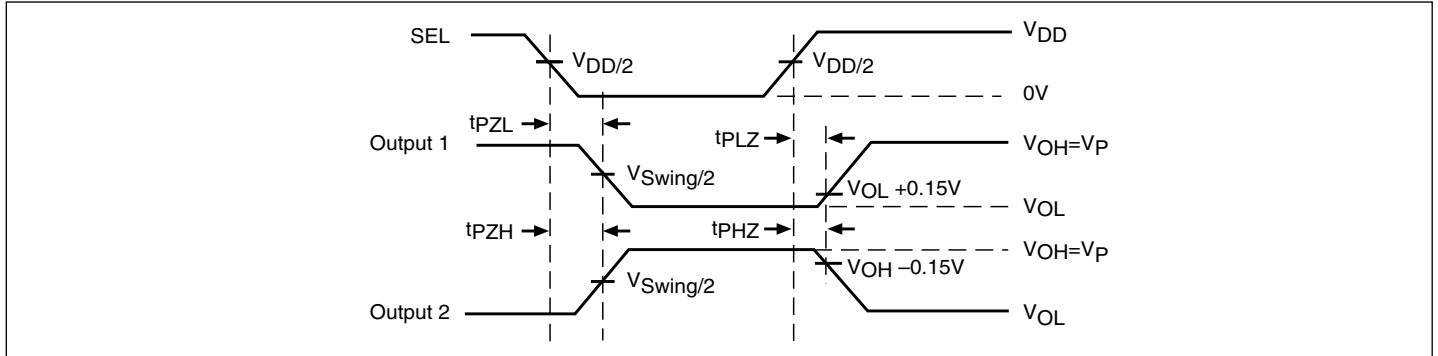

Fig 5. Skew Test

Switching Waveforms



Voltage Waveforms Enable and Disable Times

Test Circuit for Propagation Delay

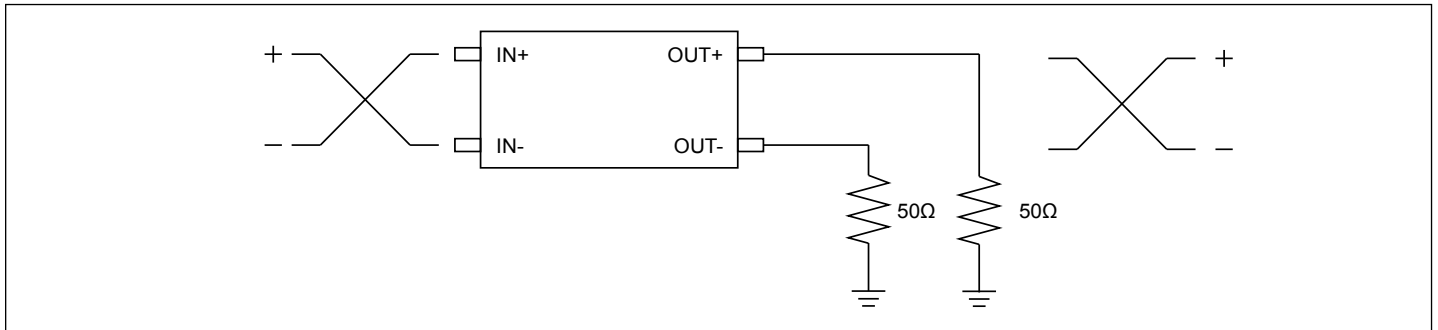

Part Marking

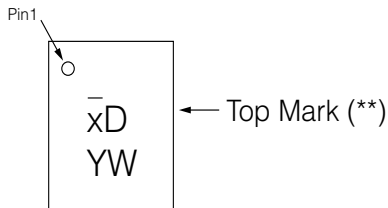

Y: Date Code (Year)

W: Date Code (Workweek)

Note: Date Code per MA-1251

Packaging Mechanical: 10-UQFN (ZUA)

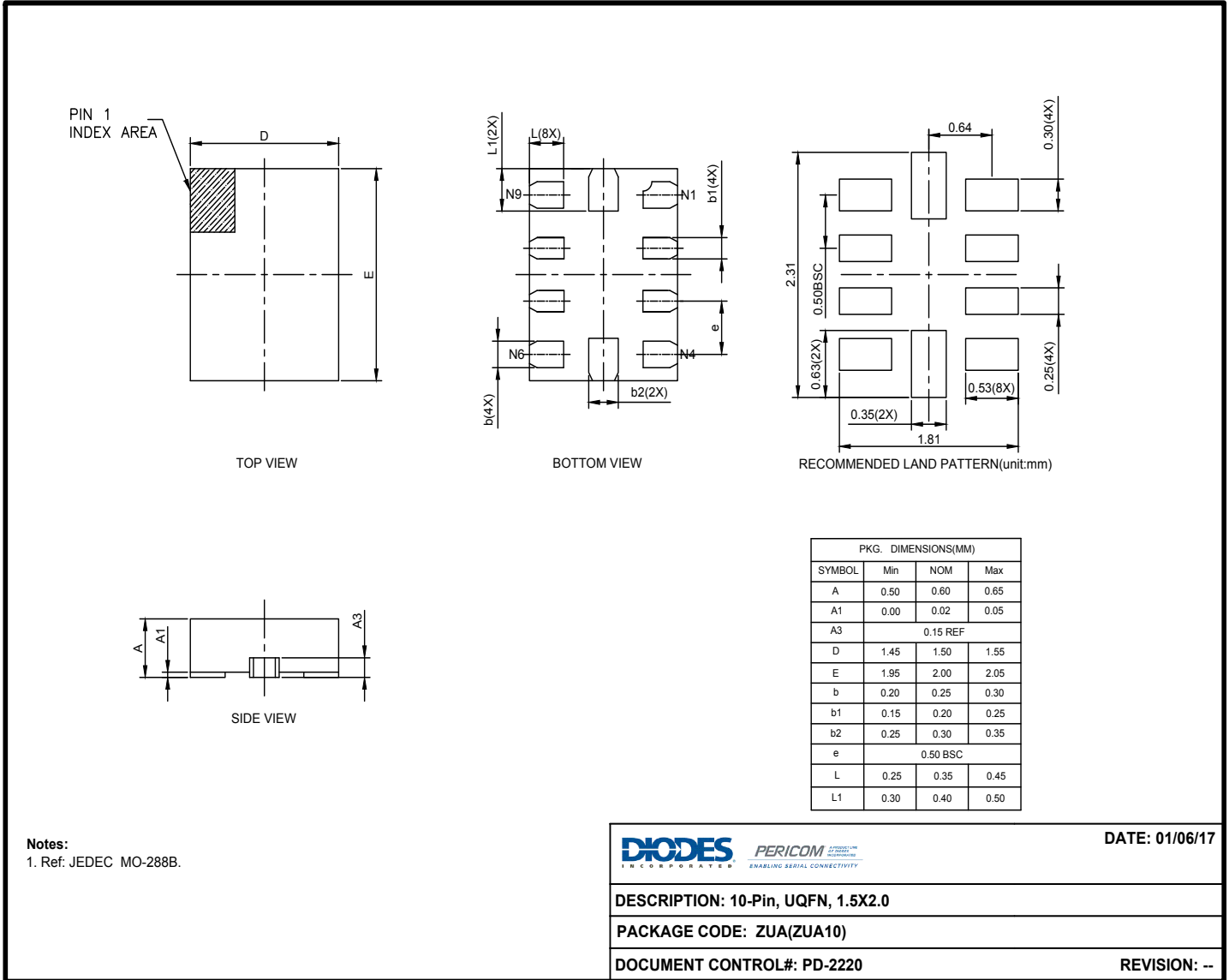

17-0002

For latest package info.

please check: <http://www.diodes.com/design/support/packaging/pericom-packaging/packaging-mechanicals-and-thermal-characteristics/>

Ordering Information

Ordering Code	Package Code	Package Description
PI3USB4000DZUAEX	ZUA	10-Pin, 1.5x2.0 (UQFN)

Notes:

1. No purposely added lead. Fully EU Directive 2002/95/EC (RoHS), 2011/65/EU (RoHS 2) & 2015/863/EU (RoHS 3) compliant.
2. See <https://www.diodes.com/quality/lead-free/> for more information about Diodes Incorporated's definitions of Halogen- and Antimony-free, "Green" and Lead-free.
3. Halogen- and Antimony-free "Green" products are defined as those which contain <900ppm bromine, <900ppm chlorine (<1500ppm total Br + Cl) and <1000ppm antimony compounds.
4. E = Pb-free and Green
5. X suffix = Tape/Reel