

Ultra-High Voltage Protection USB2 SPST Switch

Features

- Differential Bi-Directional SPST Switch
- Wide Input Voltage Range: 0-5.5V
- Wide bandwidth: 1GHz
- Ultra-low Con: 7pF
- Ultra-low Ron: 5Ω (typ)
- Low Propagation Delay, 0.25ns typ
- Low Off-Isolation, -30dB@240MHz
- Low Crosstalk: -35dB@240MHz,
- Low Power Consumption: 35μA typical
- Wide Supply Voltage 2.7-5.5V
- Protection Feature
 - ◆ Off-protection for current leakage in power-down mode
 - ◆ All I/O pins are high voltage tolerance
 - C0+/C0- tolerance to 24V
 - L0+/- tolerance to 6V
 - V_{DD} tolerance to 6V
 - ◆ Over-voltage protection when V_{bus} short to C0-/C0+ when device is power-on and enabled
- ESD Protection on (C0+/-)
 - ◆ IEC61000-4-2, 10kV
- Wide Temperature Range: -40°C to 85°C
- Totally Lead-Free & Fully RoHS Compliant (Notes 1 & 2)
- Halogen and Antimony Free. “Green” Device (Note 3)
- For automotive applications requiring specific change control (i.e. parts qualified to AEC-Q100/101/200, PPAP capable, and manufactured in IATF 16949 certified facilities), please [contact us](mailto:contact@diodes.com) or your local Diodes representative. <https://www.diodes.com/quality/product-definitions/>
- Packaging (Pb-free & Green):
 - ◆ 10-contact, UQFN (ZUA), 1.5x2mm, 0.5mm(H), 0.6mm pitch

Description

The PI3USB4002A is a High voltage short and surge protector. C0+/C0- pins can tolerate voltages up to 24V. Over-voltage protection (OVP) is implemented at 4.75V to immediately switch off the channels when over-voltage condition is detected. PI3USB4002A can pass USB2.0 signal with bandwidth 1GHz to maintain signal integrity and eye diagram open.

Applications

- Smart Phone, USB-C Application, Tablets, NB, PC

Block Diagram

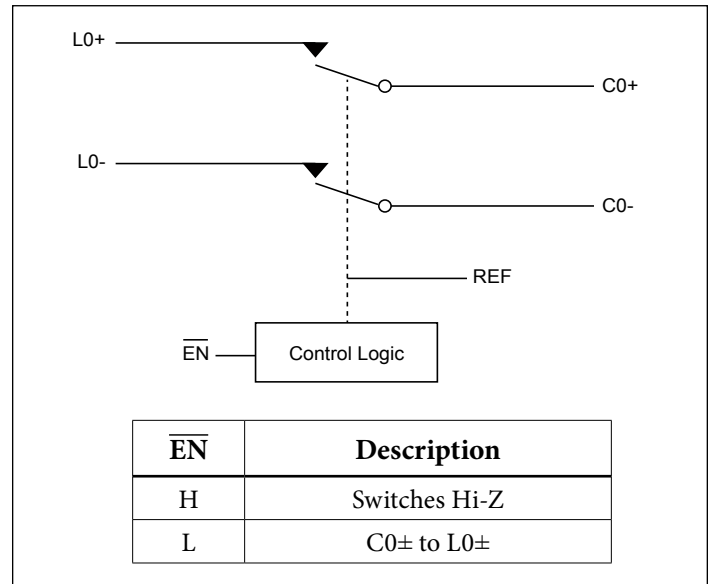

Notes:

1. No purposely added lead. Fully EU Directive 2002/95/EC (RoHS), 2011/65/EU (RoHS 2) & 2015/863/EU (RoHS 3) compliant.
2. See <https://www.diodes.com/quality/lead-free/> for more information about Diodes Incorporated’s definitions of Halogen- and Antimony-free, “Green” and Lead-free.
3. Halogen- and Antimony-free “Green” products are defined as those which contain <900ppm bromine, <900ppm chlorine (<1500ppm total Br + Cl) and <1000ppm antimony compounds.

Pin Configuration

Top View

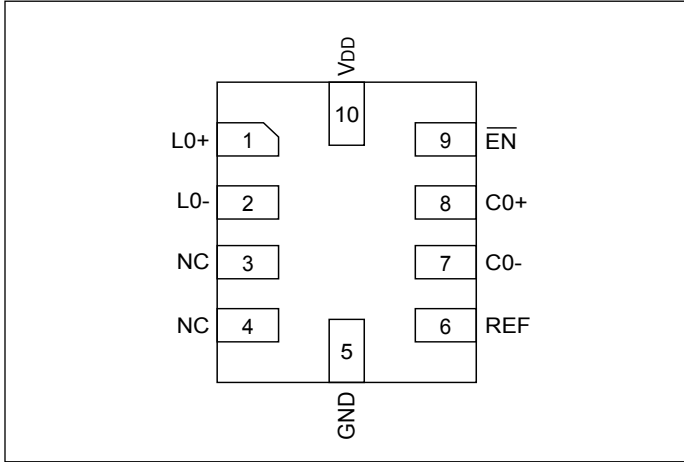

Pin Description

Pin#	Pin Name	Signal Type	Description
8, 7	C0+, C0-	I/O	Signal I/O, Port Side
3, 4	NC	NC	No Connection
1, 2	L0+, L0-	I/O	Signal I/O, System Side
9	\overline{EN}	I	$\overline{EN} = 1$, Power down is enabled. Please see Truth Table.
6	REF	PWR	Reference pin, tie to GND through cap*
5	GND	PWR	Power ground
10	V _{DD}	PWR	Positive Supply Voltage

* The Cap on the REF pin required 1uF and 25V tolerance

Truth Table

Function	\overline{EN}
C0+/- to L0+/-	L
All Switches Hi-Z	H

PI3USB4002A provide overvoltage protection for D+/- when high voltage charging

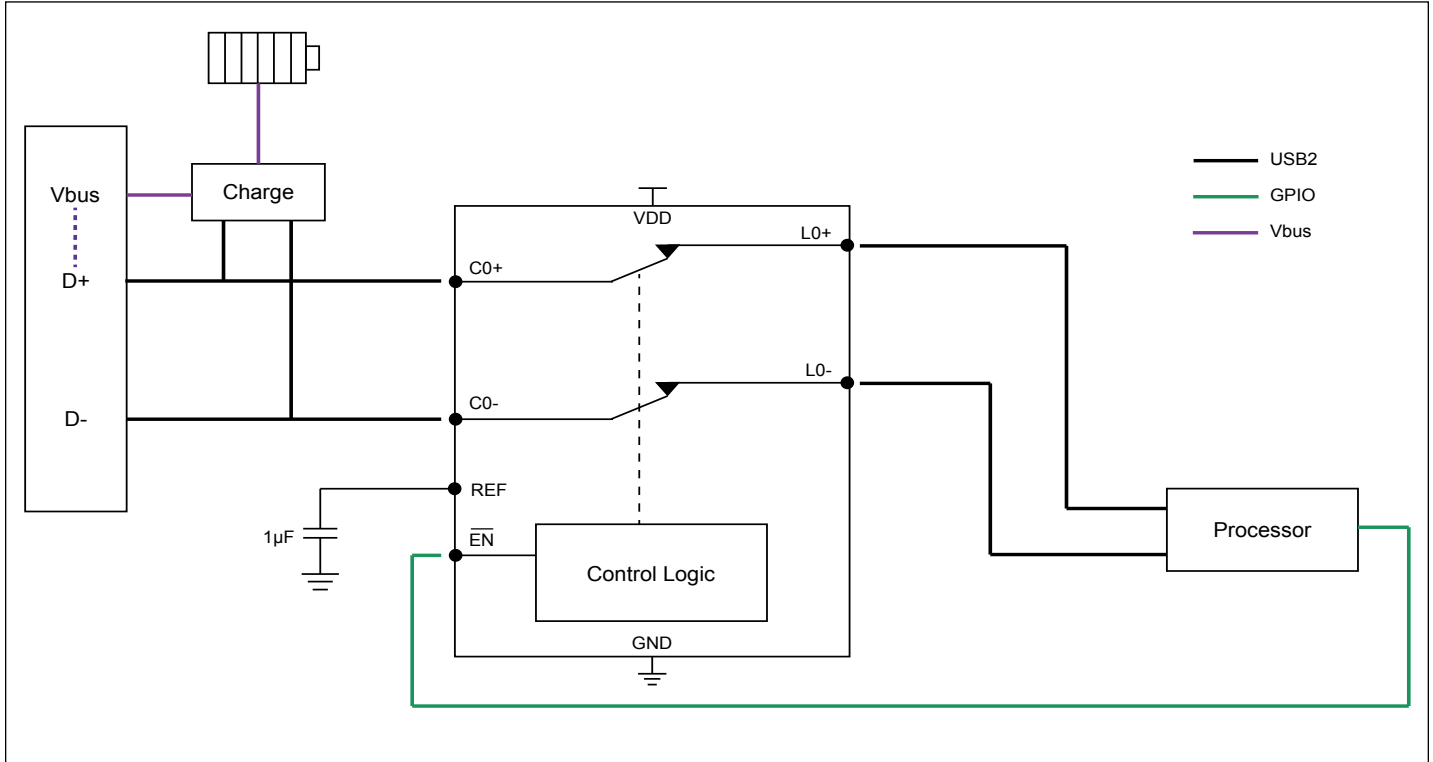

Note:

The capacitor connected to REF pin should have rated voltage higher than maximum voltage applied to C0+/- pins; the max rating of device on C0+/- is 24V, customer can select lower voltage capacitor if system required lower voltage tolerance on C0+/-; capacitance of 1uF.

1. The 1uF capacitor recommend to be placed to the REF and GND pin of the device as close as possible
2. The decoupling capacitor at the VDD recommend to be placed to the device as close as possible.
3. Keep the trace between connector and device as long as possible; if needs inductor between device and connector, it recommend to be placed to the USB connector as close as possible and leaving some trace line between the device and the inductor would help some for the ESD performance.

Maximum Ratings

(Above which useful life may be impaired. For user guidelines, not tested.)

Storage Temperature	-65°C to +150°C
Supply Voltage (VDD) to Ground Potential	-0.3V to +6V
Channel Input/Output Voltage (L0+/-)	-0.3V to +6V
Channel Input/Output Voltage (C0+/-)	-0.3V to +24V
Reference Pin Voltage (REF) to Ground Potential.....	-0.3V to +24V
Control Pins Input Voltage (\overline{EN}).....	-0.3V to +6V
ESD (All Pins).....	2KV (HBM) and 1KV (CDM)
Channel Input/Output Current (L0/C0).....	±50mA

Note:

Stresses greater than those listed under MAXIMUM RATINGS may cause permanent damage to the device. This is a stress rating only and functional operation of the device at these or any other conditions above those indicated in the operational sections of this specification is not implied. Exposure to absolute maximum rating conditions for extended periods may affect reliability.

Recommended Operating Conditions

Symbol	Description	Test Conditions	Min.	Typ.	Max.	Units
V _{DD}	Power Supply		2.7	3.3	5.5	V
V _{I/O}	Analog Voltage Range		0		5.5	V
V _I	Voltage Range for Control Pins		0		5.5	V
I _{DD}	Current Consumption in Normal Operation	V _{DD} = 3.3V, V _{I/O} = 0V, \overline{EN} = Low		35	45	μA
I _{DDQ}	Chip Disabled Current Consumption	V _{DD} = 3.3V, V _{I/O} = 0V, \overline{EN} = High		1	2	μA
T _A	Operating Temperature Range		-40		85	°C

DC Electrical Characteristics for Switching over Operating Range

(T_A = -40°C to 85°C, Typical values are at V_{DD} = 3.3V, T_A = 25°C, \overline{EN} = 0V, REF = NC (unless otherwise noted))

Parameter	Description	Test Conditions	Min.	Typ.	Max.	Units
Control Pins - \overline{EN}						
V _{IH} - cntrl signals	Input HIGH Voltage for \overline{EN}	V _{DD} = 2.7-5.5V	1.2			V
V _{IL} - cntrl signals	Input LOW Voltage for \overline{EN}	V _{DD} = 2.7-5.5V			0.6	V
I _{IH}	Input HIGH Current for \overline{EN}	V _I = 5.5V	-1		1	μA
I _{IL}	Input LOW Current for \overline{EN}	V _I = 0V	-1		1	μA
High Speed IO - L0/C0						
V _{OVP}	CO± OVP trigger voltage		4.6	4.75	5.0	V
R _{on}	ON resistance	V _{I/O} = 0V, 0.4V, I _{on} = -8mA		5	9	Ω
Δ R _{on}	On resistance between + and - channel	V _{I/O} = 0V, 0.4V, I _{on} = -8mA		0.5	1	Ω
R _{on_Flat}	ON resistance flatness	V _{I/O} = 0V, 0.4V, I _{on} = -8mA		0.2	0.5	Ω
I _{off}	CO± Power-off leakage	V _{DD} = 0V, V _{CO±} = 0 - 3.6V	-1		1	μA
I _{OC}	Channel off leakage current	\overline{EN} = V _{DD} = 3.3V, V _{I/O} = 0 - 3.6V	-1		1	μA
I _{ON}	Channel on leakage current	\overline{EN} = 0V, V _{DD} = 3.3V, V _{I/O} = 0 - 3.6V	-1		1	μA
I _{OVP}	Leakage current on C0+/C0- in OVP mode	\overline{EN} = 0V, V _{DD} = 3.3V, V _{CO+} or V _{CO-} = 20V			1	mA
Z _{ON_GND}	On state impedance to GND	\overline{EN} = 0V, V _{DD} = 3.3V, V _{I/O} = 0 - 3.6V	4	7		MΩ

Dynamic Electrical Characteristics

($T_A = -40^{\circ}\text{C}$ to 85°C , Typical values are at $V_{DD} = 3.3\text{V}$, $T_A = 25^{\circ}\text{C}$, (unless otherwise noted))

Parameter	Description	Test Conditions	Min.	Typ.	Max.	Units
Control Pins – EN						
C_I	Input Capacitance	$f=1\text{MHz}$		5		pF
High Speed IO – L0/C0						
Con	ON Capacitance	$f=1\text{MHz}$		7		pF
Coff	OFF Capacitance	$f=1\text{MHz}$		9		pF
I_L	Insertion Loss	$f=240\text{MHz}$		-0.5		dB
R_L	Return Loss	$f=240\text{MHz}$		-15		dB
O_{IRR}	OFF Isolation	$f=240\text{MHz}$		-30		dB
X_{TALK}	Crosstalk	$f=240\text{MHz}$		-35		dB
BW	-3dB Bandwidth			1		GHz

Switching Characteristics

($T_A = -40^{\circ}\text{C}$ to 85°C , Typical values are at $V_{DD} = 3.3\text{V}$, $T_A = 25^{\circ}\text{C}$, (unless otherwise noted))

Parameter	Description	Test Conditions	Min.	Typ.	Max.	Units
t_{OVP}	OVP Response Time ⁽¹⁾	$R_{L0} = 600\Omega$, time from the voltage on $C0\pm = 4\sim 6\text{V}$ to the voltage on $L0\pm = 4.75\text{V}$		0.5	1	μs
t_{pd}	Propagation Delay	See Test Circuit for Electrical Characteristics		250		ps
t_{b-b}	Bit-to-bit Skew Within the Same Differential Pair ⁽¹⁾			8	20	ps
t_{on}	Device Enable Time			100		μs
t_{off}	Device Disable Time			50		ns

Note:

1. Guaranteed by design.

PI3USB4002A

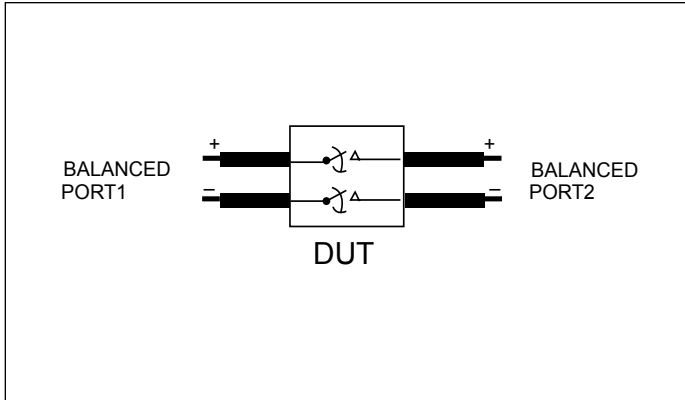

Fig 1. Differential Insertion Loss Setup

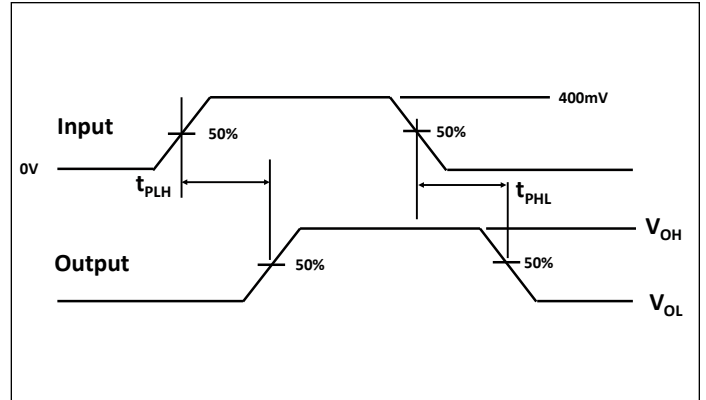

Fig 2. Propagation Delay

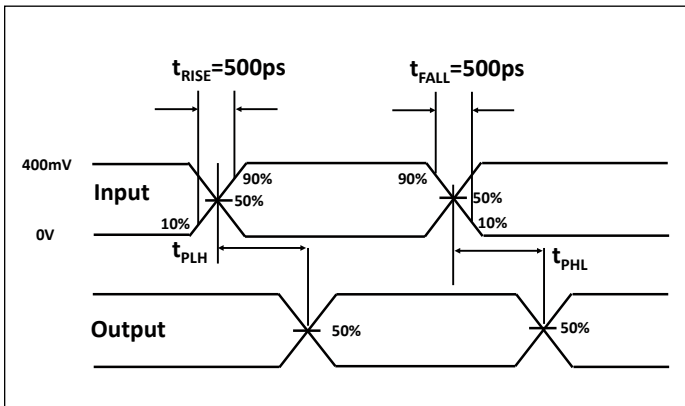
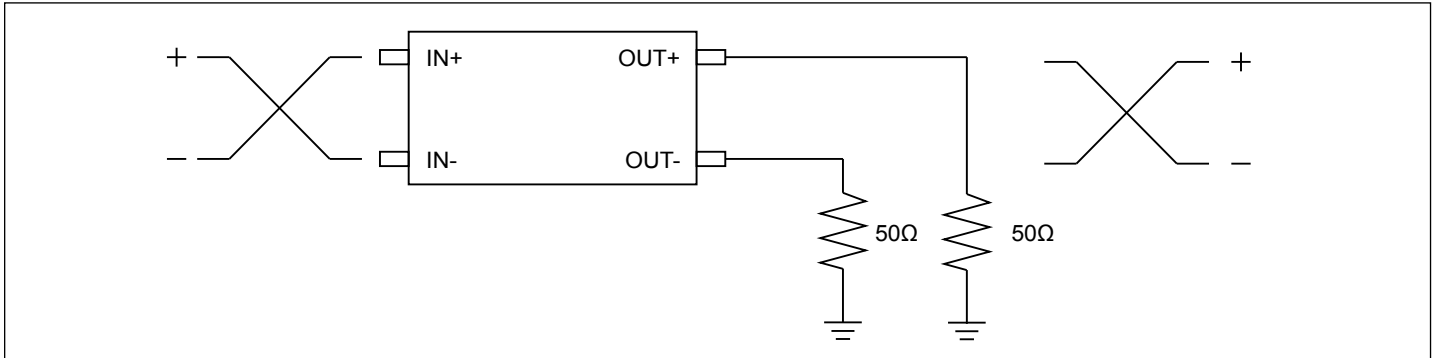

Fig 3. Skew Test

PI3USB4002A

Test Circuit for Propagation Delay



Part Marking

Top mark not available at this time. To obtain advance information regarding the top mark, please contact your local sales representative.

Packaging Mechanical: 10-UQFN (ZUA)

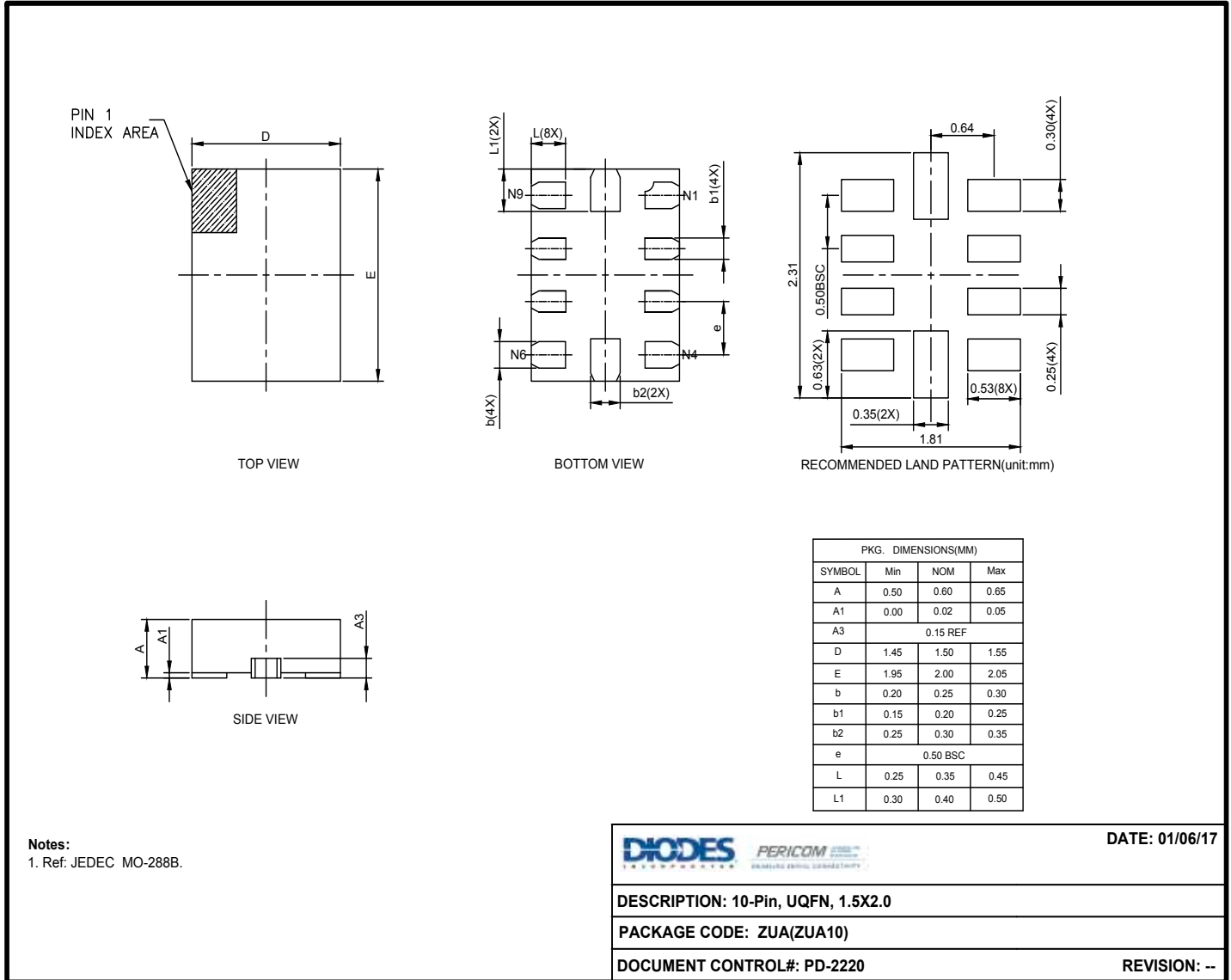

17-0002

For latest package info.

please check: <http://www.diodes.com/design/support/packaging/pericom-packaging/packaging-mechanicals-and-thermal-characteristics/>

Ordering Information

Ordering Code	Package Code	Package Description
PI3USB4002AZUAEX	ZUA	10-Pin, 1.5 x 2.0 (UQFN)

Notes:

1. No purposely added lead. Fully EU Directive 2002/95/EC (RoHS), 2011/65/EU (RoHS 2) & 2015/863/EU (RoHS 3) compliant.
2. See <https://www.diodes.com/quality/lead-free/> for more information about Diodes Incorporated's definitions of Halogen- and Antimony-free, "Green" and Lead-free.
3. Halogen- and Antimony-free "Green" products are defined as those which contain <900ppm bromine, <900ppm chlorine (<1500ppm total Br + Cl) and <1000ppm antimony compounds.
4. E = Pb-free and Green
5. X suffix = Tape/Reel