

PI49FCT3805D

3.3V, 2 x 1:5 CMOS Clock Driver

Features

- Low output skew: <200ps
- Switching frequency up to 166 MHz
- Fast output rise/fall time: <1.0ns
- Low propagation delay: <2.5ns
- Low input capacitance: <6.0pF
- Balanced CMOS outputs
- Industrial Temperature: -40°C to +85°C
- 3.3V ±10% operation, 5V Input Tolerant
- Totally Lead-Free & Fully RoHS Compliant (Notes 1 & 2)
- Halogen and Antimony Free. "Green" Device (Note 3)
- For automotive applications requiring specific change control (i.e. parts qualified to AEC-Q100/101/200, PPAP capable, and manufactured in IATF 16949 certified facilities), please [contact us](mailto:contact@diodes.com) or your local Diodes representative.
<https://www.diodes.com/quality/product-definitions/>
- Packaging (Pb-free & Green available):
 - ♦ 20-pin, 150-mil wide QSOP (Q)
 - ♦ 20-pin, 209-mil wide SSOP (H)

Description

Diodes' PI49FCT3805D is composed of non-inverting drivers. The outputs are configured into 2 groups of one-in, five-out with independent output enable. Group B has an extra MON output. Excellent output signals to power and ground ratio minimize power and ground noise and also improves output performance.

Block Diagram

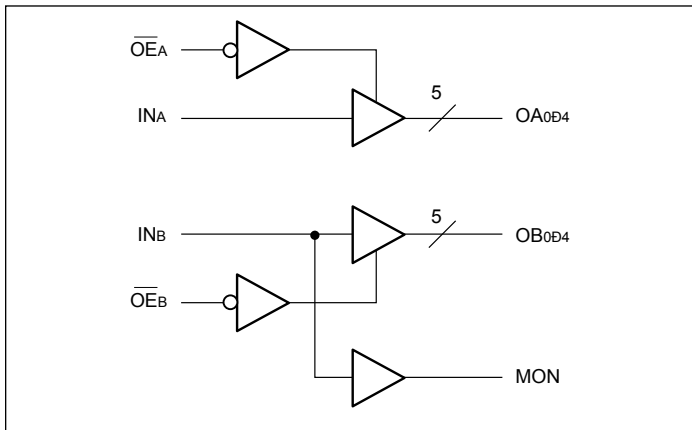

Truth Table⁽¹⁾

Inputs		Outputs	
\overline{OE}_X	IN_X	OA_X	MON
L	L	L	L
L	H	H	H
H	L	Z	L
H	H	Z	H

Note:

1. H = High Voltage Level, L = Low Voltage Level, Z = High Impedance

Notes:

1. No purposely added lead. Fully EU Directive 2002/95/EC (RoHS), 2011/65/EU (RoHS 2) & 2015/863/EU (RoHS 3) compliant.
2. See <https://www.diodes.com/quality/lead-free/> for more information about Diodes Incorporated's definitions of Halogen- and Antimony-free, "Green" and Lead-free.
3. Halogen- and Antimony-free "Green" products are defined as those which contain <900ppm bromine, <900ppm chlorine (<1500ppm total Br + Cl) and <1000ppm antimony compounds.

Pin Configuration

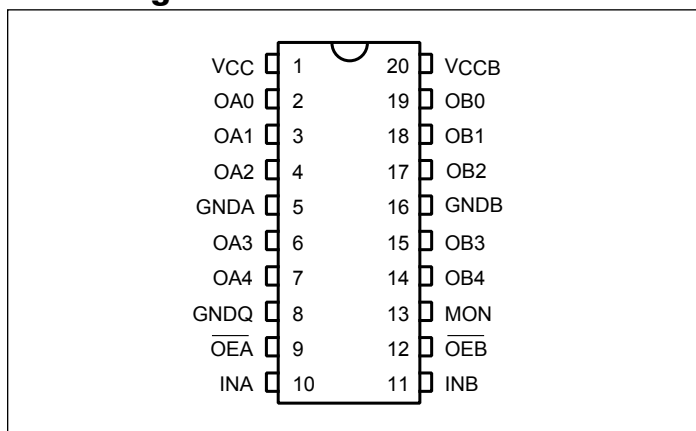

Pin Description

Pin Name	Description
\overline{OE}_X	Hi-Z State Output Enable Inputs (Active Low)
IN_X	Clock Inputs
OA_N, OB_N	Clock Outputs
MON	Monitor Output
GND	Ground
VCC	Power

Maximum Ratings

(Above which the useful life may be impaired. For user guidelines, not tested.)

Storage Temperature	-65°C to +150°C
Ambient Temperature with Power Applied	-40°C to +85°C
Input Voltage to GND Potential (Inputs & V _{CC} Only)	-0.5V to 5.5V
Output Voltage to GND Potential (Outputs & I/O Only)...	-0.5V to +V _{CC} +0.5V
V _{CC} Input Voltage	-0.5V to +4.6V

Note:

Stresses greater than those listed under MAXIMUM RATINGS may cause permanent damage to the device. This is a stress rating only and functional operation of the device at these or any other conditions above those indicated in the operational sections of this specification is not implied. Exposure to absolute maximum rating conditions for extended periods may affect reliability.

DC Electrical Characteristics (T_A = -40°C to +85°C, V_{CC} = 3.3V ± 0.3V)

Symbol	Parameters	Test Conditions ⁽¹⁾	Min.	Typ.	Max.	Units
V _{OH}	Output High Voltage V _{CC} = Min., V _{IN} = V _{IL} or V _{IH}	I _{OH} = -0.1mA I _{OH} = -8mA I _{OH} = -12mA	V _{CC} -0.2 2.4 ⁽³⁾ 2.4 ⁽³⁾	- 3.0 3.0		V
V _{OL}	Output Low Voltage V _{CC} = Min., V _{IN} = V _{IL} or V _{IH}	I _{OH} = 0.1mA I _{OH} = 8mA I _{OH} = 12mA		- 0.2 0.3	0.2 0.4 0.4	
V _{IH}	Input High Voltage	Low Logic	2.0		5.5	
V _{IL}	Input Low Voltage	High Logic	-0.5		0.8	
I _{IH}	Input High Current	V _{CC} = Max., V _{IN} = 5.5V			1	µA
I _{IL}	Input Low Current	V _{CC} = Max., V _{IN} = GND			-1	
I _{OZH} I _{OZL}	High Impedance output current	V _{CC} = Max., all outputs disabled			1 -1	
V _{IK}	Clamp Diode Voltage	V _{CC} = Min., I _{IN} = -18mA		-0.7	-1.2	V
I _{ODH}	Output High Current ^(4, 5)	V _{OUT} = 1.5V, V _{IN} = V _{IL} or V _{IH} , V _{CC} = 3.3V	-40	-74	-100	mA
I _{ODL}	Output Low Current ^(4, 5)	V _{OUT} = 1.5V, V _{IN} = V _{IL} or V _{IH} , V _{CC} = 3.3V	50	90	130	
I _{OS}	Short Circuit Current ^(4, 5)	V _{CC} = Max., V _{OUT} = GND	-60	-100	-120	

Notes:

1. For Max. or Min. conditions, use appropriate value specified under Electrical Characteristics for the applicable device type.
2. Typical values are at V_{CC} = 3.3V, +25°C ambient and maximum loading.
3. V_{OH} = V_{CC} - 0.6V at rated current.
4. This parameter is determined by device characterization but is not production tested.
5. Not more than one output should be shorted at one time. Duration of the test should not exceed one second.

Capacitance (T_A = 25°C, f = 1 MHz)

Parameters ⁽¹⁾	Description	Test Conditions	Typ	Max.	Units
C _{IN}	Input Capacitance	V _{IN} = 0V	3.0	4	pF
C _{OUT}	Output Capacitance	V _{OUT} = 0V	—	6	

Note:

1. This parameter is determined by device characterization but is not production tested.

Power Supply Characteristics

Parameters	Description	Test Conditions ⁽¹⁾		Min.	Typ. ⁽²⁾	Max.	Units
I_{CC}	Quiescent Power Supply Current	$V_{CC} = \text{Max.}$	$V_{IN} = \text{GND or } V_{DD}$		0.1	30	μA
I_{DD}	Dynamic Supply Current per Output	$V_{CC} = 3.6\text{V},$ $C_L = 15\text{pF},$ All Outputs Toggling			80	120	
I_C	Total Power Supply Current	$V_{CC} = 3.6\text{V},$ $C_L = 15\text{pF},$ All Outputs Toggling, $f_i = 133\text{ MHz}$	$V_{IN} = V_{CC} \text{ or GND}$		100	135	mA/ MHz
			$V_{IN} = V_{CC} - 0.6\text{V or GND}$		100	135	
		$V_{CC} = 3.6\text{V},$ $C_L = 15\text{pF},$ All Outputs Toggling, $f_i = 166\text{ MHz}$	$V_{IN} = V_{CC} \text{ or GND}$		120	160	
			$V_{IN} = V_{CC} - 0.6\text{V or GND}$		120	160	
ΔI_{CC}	Supply Current per inputs @ TTL High	$V_{CC} = \text{Max.}$	$V_{IN} = V_{CC} - 0.6\text{V}^{(3)}$		45	300	μA

Notes:

1. For Max. or Min. conditions, use appropriate value specified under Electrical Characteristics for the applicable device.
2. Typical values are at $V_{CC} = 3.3\text{V}, +25^\circ\text{C}$ ambient.
3. Per TTL driven input ($V_{IN} = V_{CC} - 0.6\text{V}$); all other inputs at V_{CC} or GND.

Switching Characteristics over Operating Range

Parameters	Description	Test Conditions ⁽¹⁾	3805D	Units
			Max.	
t _{PLH} t _{PHL}	Propagation Delay I _{NN} to O _N	C _L = 15pF, 133 MHz (3805D)	3.0	ns
t _R /t _F	CLKn Rist/Fall Time 0.8V ~ 2.0V		1.5	ns
t _{SK(o)} ⁽³⁾	Pulse Skew		270	ps
t _{SK(p)} ⁽³⁾	Output Skew		270	
t _{SK(t)} ⁽³⁾	Package Skew		550	
t _{ZL} , t _{ZH} , t _{LZ} , t _{HZ}	Enable/Disable Time		5.2	ns
F _{MAX}	Input Frequency		133	MHz

Note:

1. These parameters are guaranteed by design
2. Series Resistor loading = 33Ω (See Test Circuit)

Switch Position

Test	Switch
Disable LOW Enable LOW	6V
Disable HIGH Enable HIGH	GND
All Other Inputs	Open

Definitions:

1. C_L = Load capacitance: includes jig and probe capacitance.
2. R_T = Termination resistance: should be equal to Z_{OUT} of the Pulse Generator.

Tests Circuit

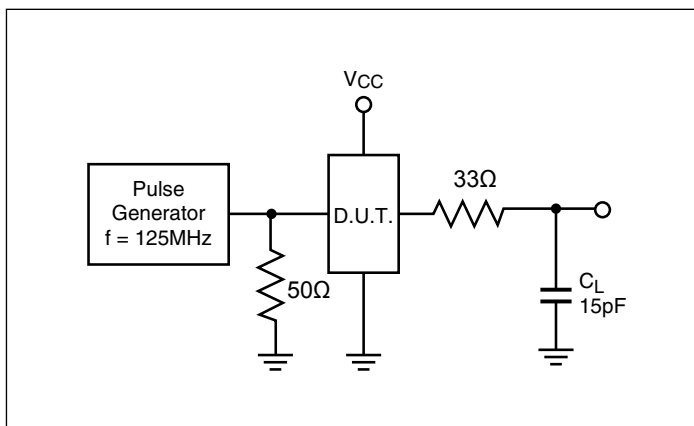

Enable/Disable Time Test Set-Up

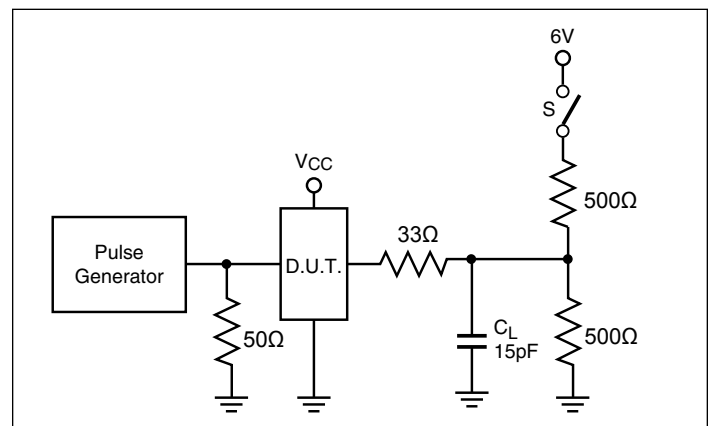

Switching Waveforms

Propagation Delay

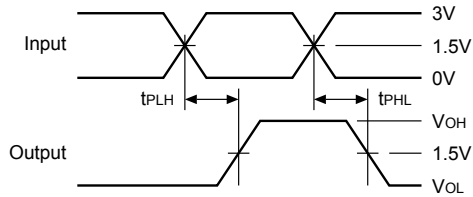

Enable and Disable Times

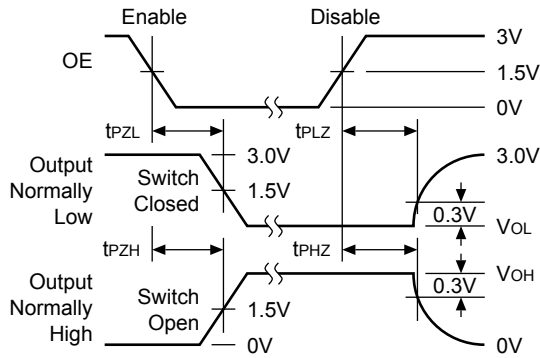

Package Skew – tsk(t)

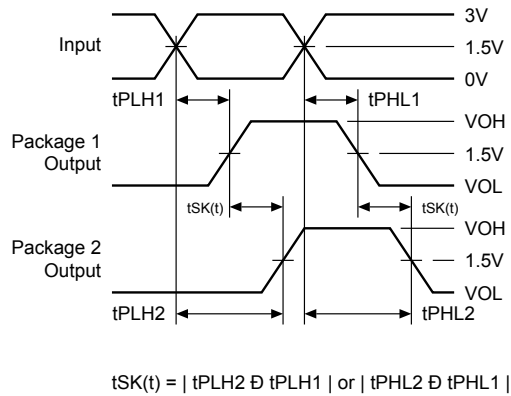

$tSK(t) = | tPLH2 \ominus tPLH1 | \text{ or } | tPHL2 \ominus tPHL1 |$

Output Skew – tsk(o)

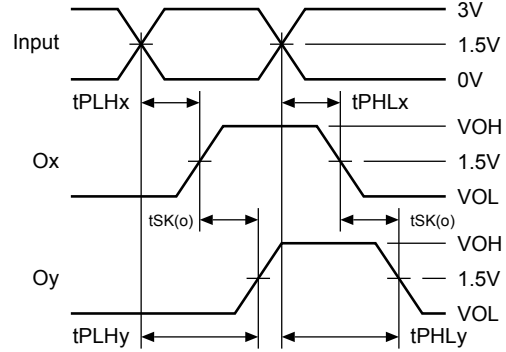

$tSK(o) = | tPLHy \ominus tPLHx | \text{ or } | tPHLy \ominus tPHLx |$

Pulse Skew – tsk(p)

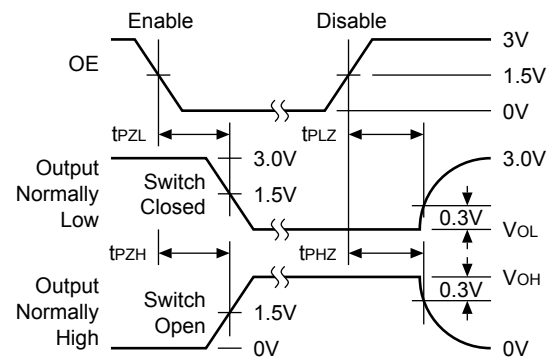

PI49FCT3805D

Part Marking

H Package



YY: Year
WW: Workweek
1st X: Assembly Code
2nd X: Fab Code

Q Package



YY: Year
WW: Workweek
1st X: Assembly Code
2nd X: Fab Code

PI49FCT3805D

Packaging Mechanical: 20-SSOP (H)

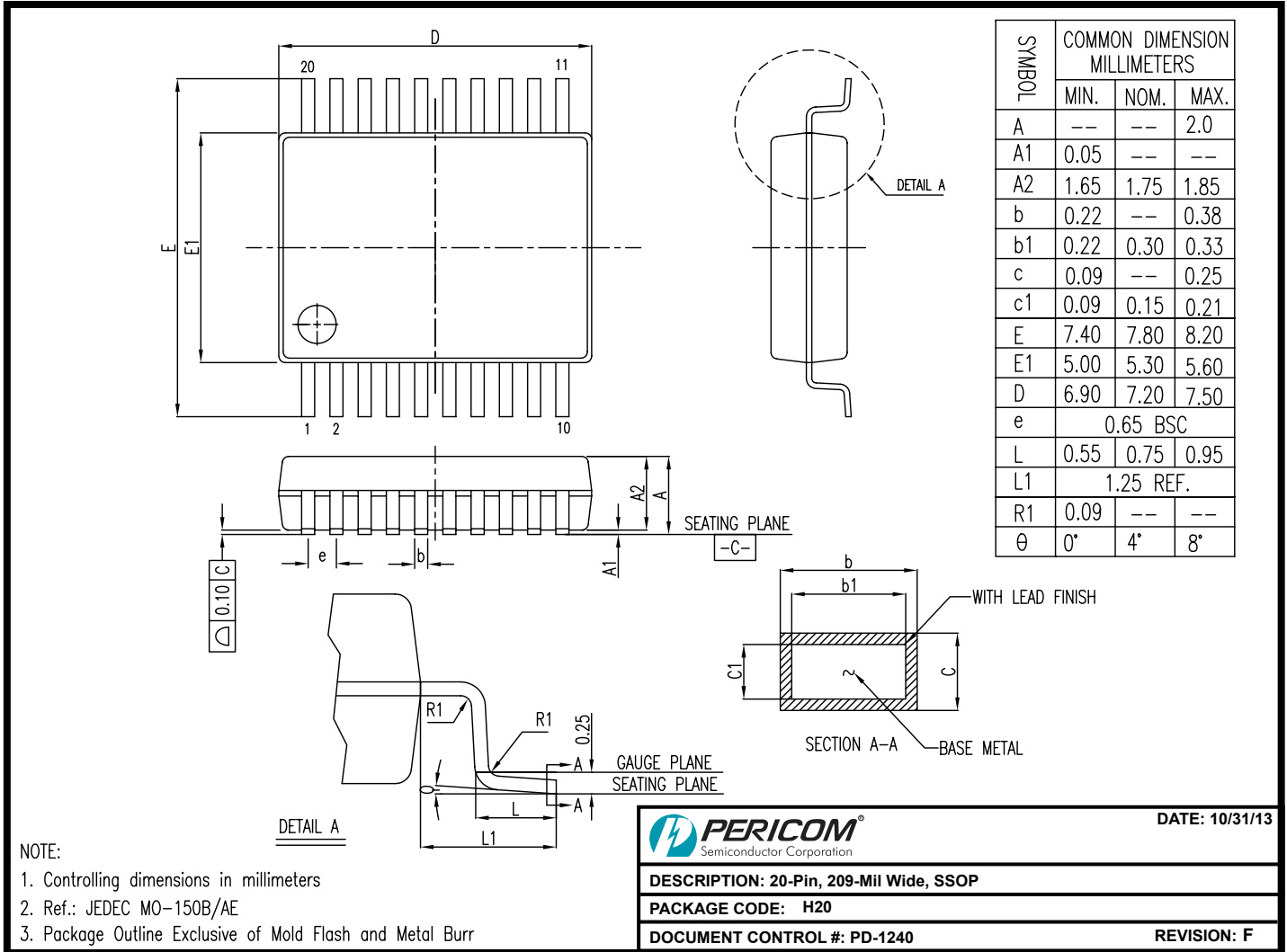

13-0214

Packaging Mechanical: 20-QSOP (Q)

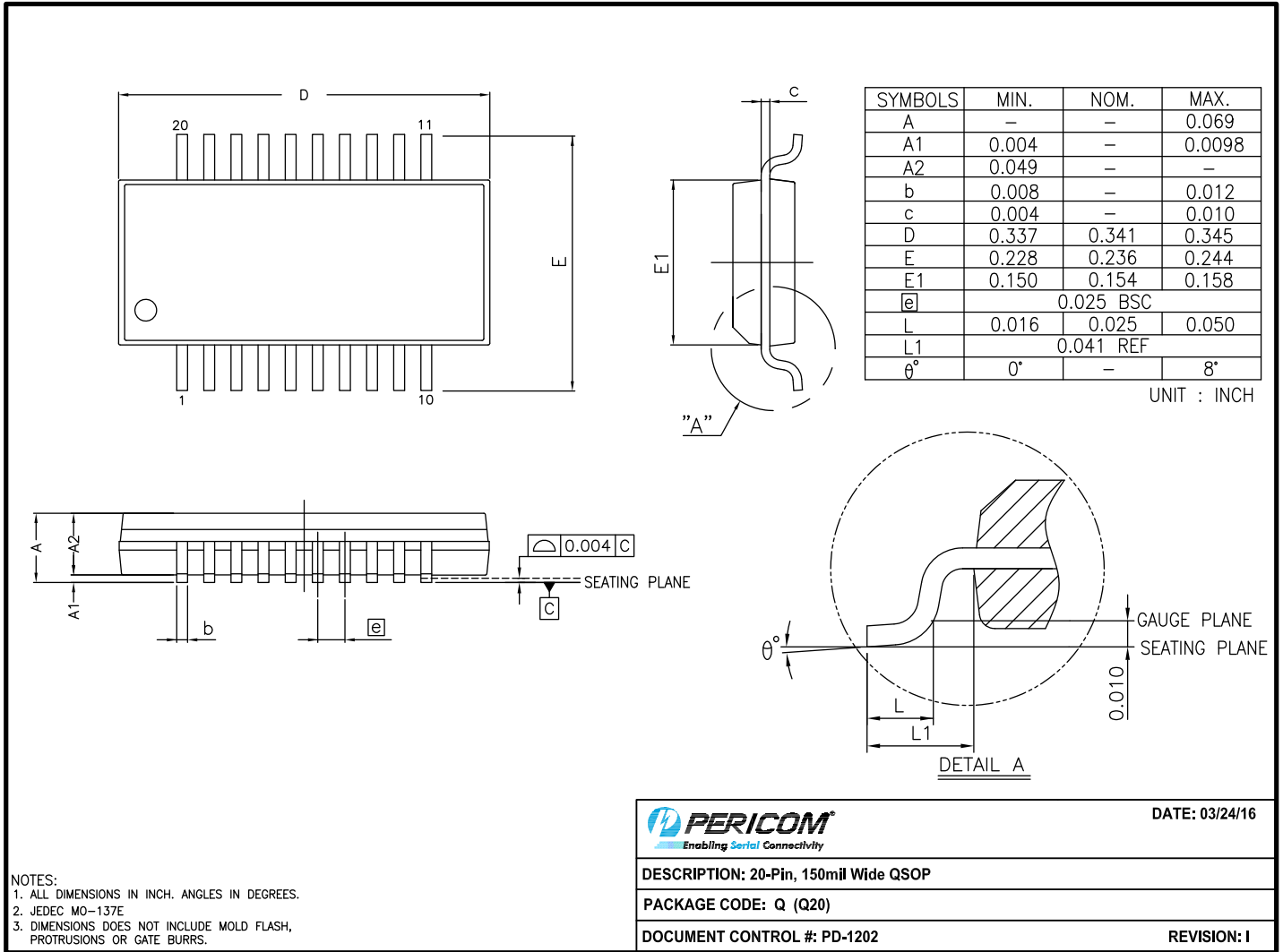

16-0057

For latest package info.

please check: <http://www.diodes.com/design/support/packaging/pericom-packaging/packaging-mechanicals-and-thermal-characteristics/>

Ordering Information

Ordering Code	Package Code	Package Description
PI49FCT3805DHEX	H	20-pin, 209-mil Wide (SSOP)
PI49FCT3805DQEX	Q	20-pin, 150-mil Wide (QSOP)

Notes:

1. No purposely added lead. Fully EU Directive 2002/95/EC (RoHS), 2011/65/EU (RoHS 2) & 2015/863/EU (RoHS 3) compliant.
2. See <https://www.diodes.com/quality/lead-free/> for more information about Diodes Incorporated's definitions of Halogen- and Antimony-free, "Green" and Lead-free.
3. Halogen- and Antimony-free "Green" products are defined as those which contain <900ppm bromine, <900ppm chlorine (<1500ppm total Br + Cl) and <1000ppm antimony compounds.
4. E = Pb-free and Green
5. X suffix = Tape/Reel