

Description

The DIODES PI49FCT3807 is a 3.3V 1-to-10 clock driver. This low skew clock driver features one input and ten outputs fanout. The large fanout from a single input line reduced loading on input clock. TTL level outputs reduce noise levels on the part. Typical applications are clock and signal distribution.

Block Diagram

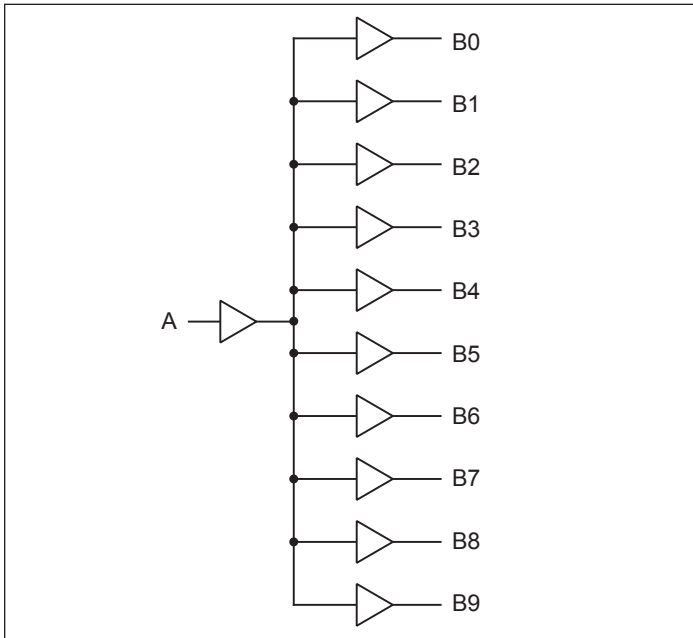

Features

- 3.3V Version of PI49FCT807
- Ultra Low Skew: 0.35ns
- Low Input Capacitance
- Minimum Duty Cycle Distortion
- 1:10 Fanout
- High Speed: 3.5ns Propagation
- TTL Input and CMOS Output Compatible
 - VOH = 3.3V (typical)
 - VOL = 0.3V (typical)
- Industrial Temperature: -40°C to +85°C
- 3.3V ±10% Operation
- Totally Lead-Free & Fully RoHS Compliant (Notes 1 & 2)
- Halogen and Antimony Free. "Green" Device (Note 3)
- For automotive applications requiring specific change control (i.e. parts qualified to AEC-Q100/101/104/200, PPAP capable, and manufactured in IATF 16949 certified facilities), please [contact us](mailto:contact@diodes.com) or your local Diodes representative. <https://www.diodes.com/quality/product-definitions/>
- Packaging (Pb-free & Green):
 - 20-pin 150-mil wide QSOP (Q)
 - 20-pin 209-mil wide SSOP (H)

Notes:

1. No purposely added lead. Fully EU Directive 2002/95/EC (RoHS), 2011/65/EU (RoHS 2) & 2015/863/EU (RoHS 3) compliant.
2. See <https://www.diodes.com/quality/lead-free/> for more information about Diodes Incorporated's definitions of Halogen- and Antimony-free, "Green" and Lead-free.
3. Halogen- and Antimony-free "Green" products are defined as those which contain <900ppm bromine, <900ppm chlorine (<1500ppm total Br + Cl) and <1000ppm antimony compounds.

Pin Configuration

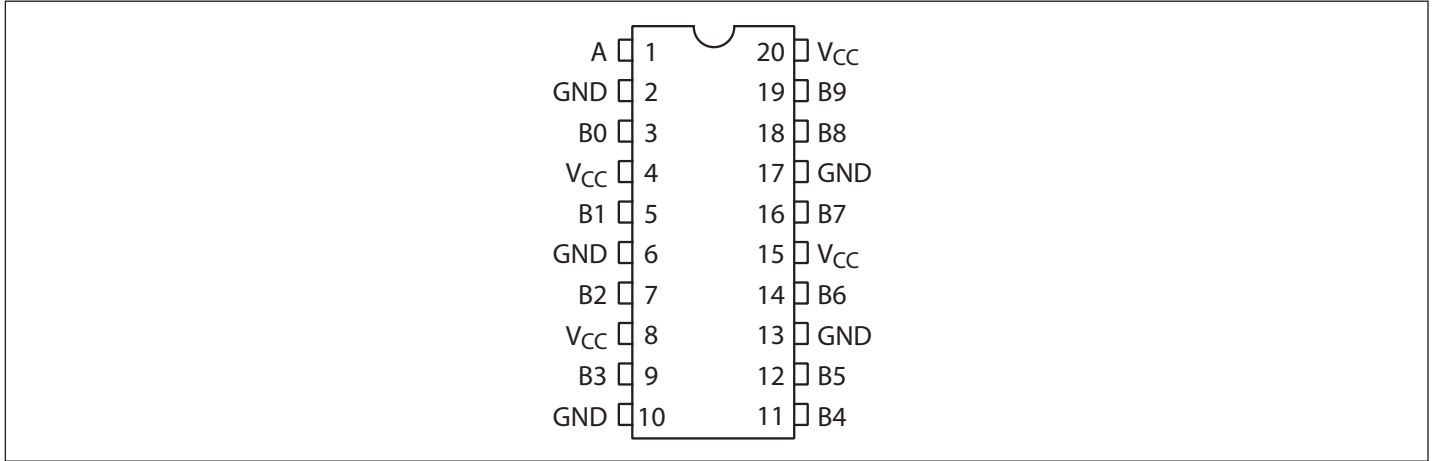

Pin Description

Pin #	Pin Name	Type	Description
1	A	I	Input Clock
3	B ₀	O	Output Clock
5	B ₁	O	Output Clock
7	B ₂	O	Output Clock
9	B ₃	O	Output Clock
11	B ₄	O	Output Clock
12	B ₅	O	Output Clock
14	B ₆	O	Output Clock
16	B ₇	O	Output Clock
18	B ₈	O	Output Clock
19	B ₉	O	Output Clock
2, 6, 10, 13, 17	GND	Ground	Ground Supply
4, 8, 15, 20	V _{CC}	Power	Power Supply

Maximum Ratings

(Above which the useful life may be impaired. For user guidelines, not tested.)

Storage Temperature	-65°C to +150°C
Ambient Temperature with Power Applied	-40°C to +85°C
Supply Voltage to Ground Potential (Inputs & V _{CC} Only).....	-0.5V to +7.0V
Supply Voltage to Ground Potential (Outputs & D/O Only) ..	-0.5V to +7.0V
DC Input Voltage	-0.5V to +7.0V
DC Output Current.....	120mA
Power Dissipation	0.5W
Latchup	200mA
ESD Protection (Input)	2000V min (HBM)
Junction Temperature.....	125 °C max

Note:

Stresses greater than those listed under MAXIMUM RATINGS may cause permanent damage to the device. This is a stress rating only and functional operation of the device at these or any other conditions above those indicated in the operational sections of this specification is not implied. Exposure to absolute maximum rating conditions for extended periods may affect reliability.

DC Electrical Characteristics

T_A = -40°C to +85°C V_{CC} = 3.3V ±0.3V

Symbol	Parameter	Test Condition ⁽¹⁾	Min.	Typ.	Max.	Units
V _{OH}	Output High Voltage	V _{CC} = Min., V _{IN} = V _{IL} or V _{IH}	I _{OH} = -0.1mA I _{OH} = -8mA	V _{CC} - 0.2 2.4	- 3.0	V
V _{OL}	Output Low Voltage	V _{CC} = Min., V _{IN} = V _{IL} or V _{IH}	I _{OH} = 0.1mA I _{OH} = 16mA I _{OH} = 24mA	- 0.2 0.3	0.2 0.4 0.5	
V _{IH}	Input High Voltage	Guaranteed Logic HIGH Level (Input pins)		2.0	5.5	
V _{IL}	Input Low Voltage	Guaranteed Logic LOW Level (Input pins)		-0.5	0.8	
I _{IH}	Input High Current	V _{CC} = Max.	V _{IN} = V _{CC}		1	μA
I _{IL}	Input Low Current	V _{CC} = Max.	V _{IN} = GND		-1	
V _{IK}	Clamp Diode Voltage	V _{CC} = Min., I _{IN} = -18mA			-0.7 -1.2	V
I _{OH}	Output HIGH Current ^(4,5)	V _{OUT} = 1.5V, V _{IN} = V _{IL} or V _{IH} , V _{CC} = 3.3V		-35	-60	mA
I _{OL}	Output LOW Current ^(4,5)	V _{OUT} = 1.5V, V _{IN} = V _{IL} or V _{IH} , V _{CC} = 3.3V		50	90	
I _{OS}	Short Circuit Current ^(4,5)	V _{CC} = Max., V _{OUT} = GND		-60	-135	
V _H	Input Hysteresis				150	mV

Notes:

1. For Max. or Min. conditions, use appropriate value specified under Electrical Characteristics for the applicable device type.
2. Typical values are at V_{CC} = 3.3V, +25°C ambient and maximum loading.
3. V_{OH} = V_{CC} - 0.6V at rated current.
4. This parameter is determined by device characterization but is not production tested.
5. Not more than one output should be shorted at one time. Duration of the test should not exceed one second.

Power Supply Characteristics

Parameters	Description	Test Conditions ⁽¹⁾		Min.	Typ ⁽²⁾	Max.	Units
I_{CC}	Quiescent Power Supply Current	$V_{CC} = \text{Max.}$	$V_{IN} = \text{GND or } V_{CC}$		3	30	μA
ΔI_{CC}	Supply Current per Inputs @ TTL HIGH	$V_{CC} = \text{Max.}$	$V_{IN} = V_{CC} - 0.6\text{V}^{(3)}$		2.0	300	
I_{CCD}	Supply Current per Input per MHz ⁽⁴⁾	$V_{CC} = \text{Max.}, \text{Outputs OpenPer Output Toggling } 50\% \text{ Duty Cycle}$	$V_{IN} = V_{CC}$ $V_{IN} = \text{GND}$				mA/MHz

Notes:

- For Max. or Min. conditions, use appropriate value specified under Electrical Characteristics for the applicable device.
- Typical values are at $V_{CC} = 3.3\text{V}, +25^\circ\text{C}$ ambient.
- Per TTL driven input ($V_{IN} = V_{CC} - 0.6\text{V}$); all other inputs at V_{CC} or GND.
- This parameter is not directly testable, but is derived for use in Total Power Supply Calculations.
- Values for these conditions are examples of the I_C formula. These limits are guaranteed but not tested.

Capacitance

$T_A = 25^\circ\text{C}, f = 1 \text{ MHz}$

Parameters ⁽¹⁾	Description	Test Conditions	Typ	Max.	Units
C_{IN}	Input Capacitance	$V_{IN} = 0\text{V}$	4.5	6.0	pF
C_{OUT}	Output Capacitance	$V_{OUT} = 0\text{V}$	5.5	8.0	

Notes:

- This parameter is determined by device characterization but is not production tested.

Maximum Switching Characteristics

Over operating range

Symbol	Description	Test Conditions	3807		3087A		3087B		3807C		Units
			Com.		Com.		Com.		Com.		
			Min.	Max.	Min.	Max.	Min.	Max.	Min.	Max.	
t_{PLH} t_{PHL}	Propagation Delay A to B_N	$C_L = 15\text{pF}$ $R_L = 500\Omega$	1.5	4.5	1.5	4.0	1.5	3.8	1.5	3.5	ns
$t_{SK(O)}$	Skew between two outputs of same package ⁽³⁾			0.5		0.5		0.5		0.5	
$t_{SK(P)}$	Skew between opposite transitions of the same output ($t_{PHL} - t_{PHL}$) ⁽³⁾			0.5		0.5		0.35		0.35	
t_{DC}	Duty Cycle										
F_{IN}	Skew between outputs of different packages at the same power supply, temp. and speed grade ⁽³⁾			1.0		1.0		0.75		0.75	

Notes:

- Other loading condition is described on page 4, "Test Circuits for All Outputs."
- These parameters are guaranteed by design.
- Minimum propagation delay of 1.5ns is guaranteed by design.

Phase Jitter Measurement Data

Frequency Band	Input	Output	Additive Jitter	Unit
12kHz-10MHz	342	483	341	fs _{RMS}
12kHz-20MHz	493	642	411	fs _{RMS}

Tests Circuits for All Outputs

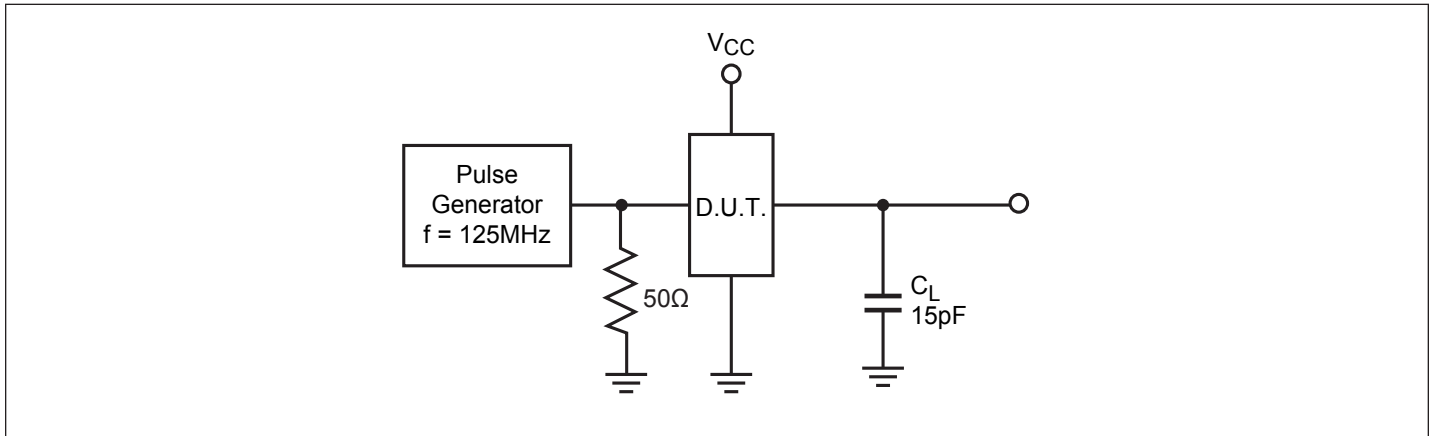

Switch Position

Test	Switch
Disable LOW Enable LOW	6V
Disable HIGH Enable HIGH	GND
All Other Inputs	Open

Switching Waveforms

Propagation Delay

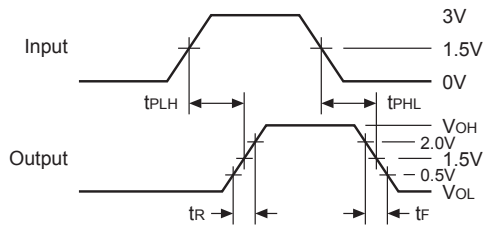

Pulse Skew – $t_{sk(p)}$

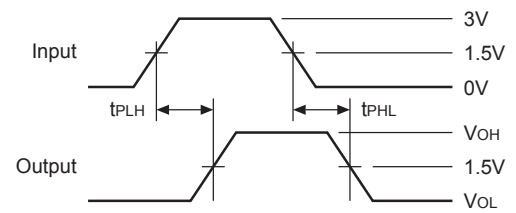

$$t_{sk(p)} = |t_{PHL} - t_{PLH}|$$

Output Skew – $t_{sk(o)}$

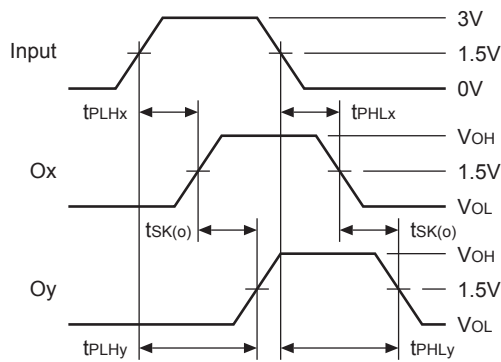

$$t_{sk(o)} = |t_{PLHy} - t_{PLHx}| \text{ or } |t_{PHLy} - t_{PHLx}|$$

Package Skew – $t_{sk(t)}$

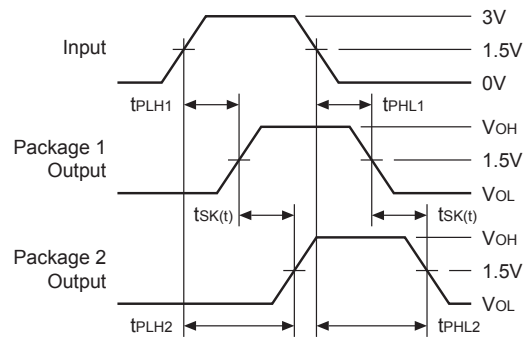

$$t_{sk(t)} = |t_{PLH2} - t_{PLH1}| \text{ or } |t_{PHL2} - t_{PHL1}|$$

Part Marking

H Package



D: Speed Code
 YY: Year
 WW: Workweek
 1st X: Assembly Code
 2nd X: Fab Code

Q Package

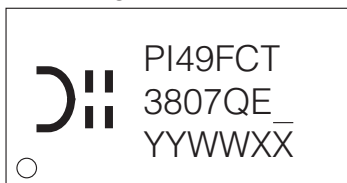

YY: Year
 WW: Workweek
 1st X: Assembly Code
 2nd X: Fab Code

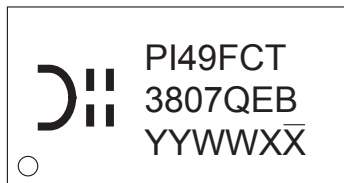

B: Speed Code
 YY: Year
 WW: Workweek
 1st X: Assembly Code
 2nd X: Fab Code

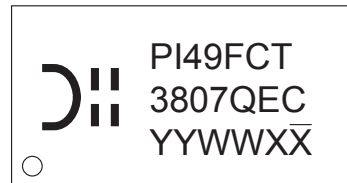

C: Speed Code
 YY: Year
 WW: Workweek
 1st X: Assembly Code
 2nd X: Fab Code

Packaging Mechanical

20-SSOP (H)

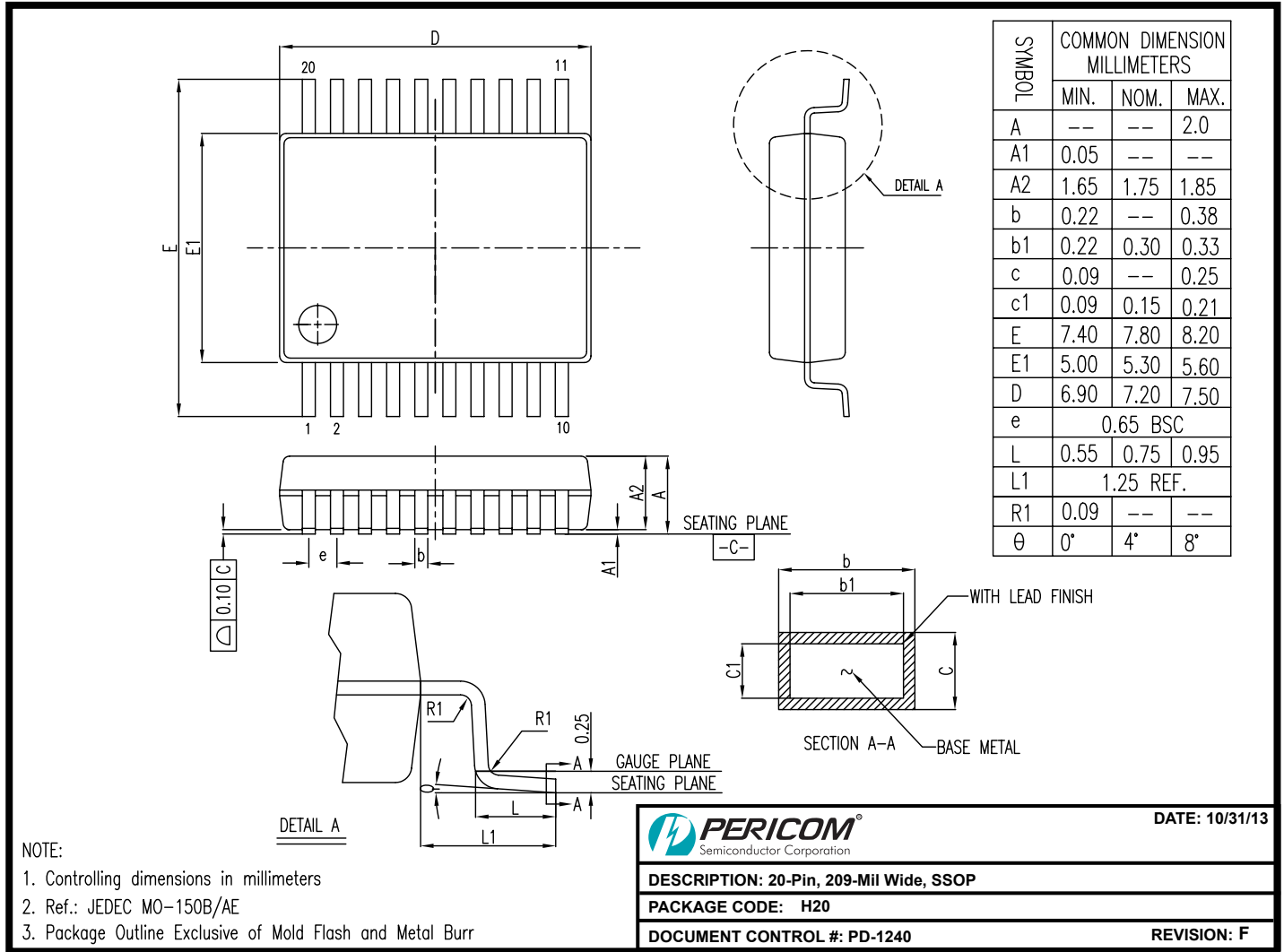

13-0214

20-QSOP (Q)

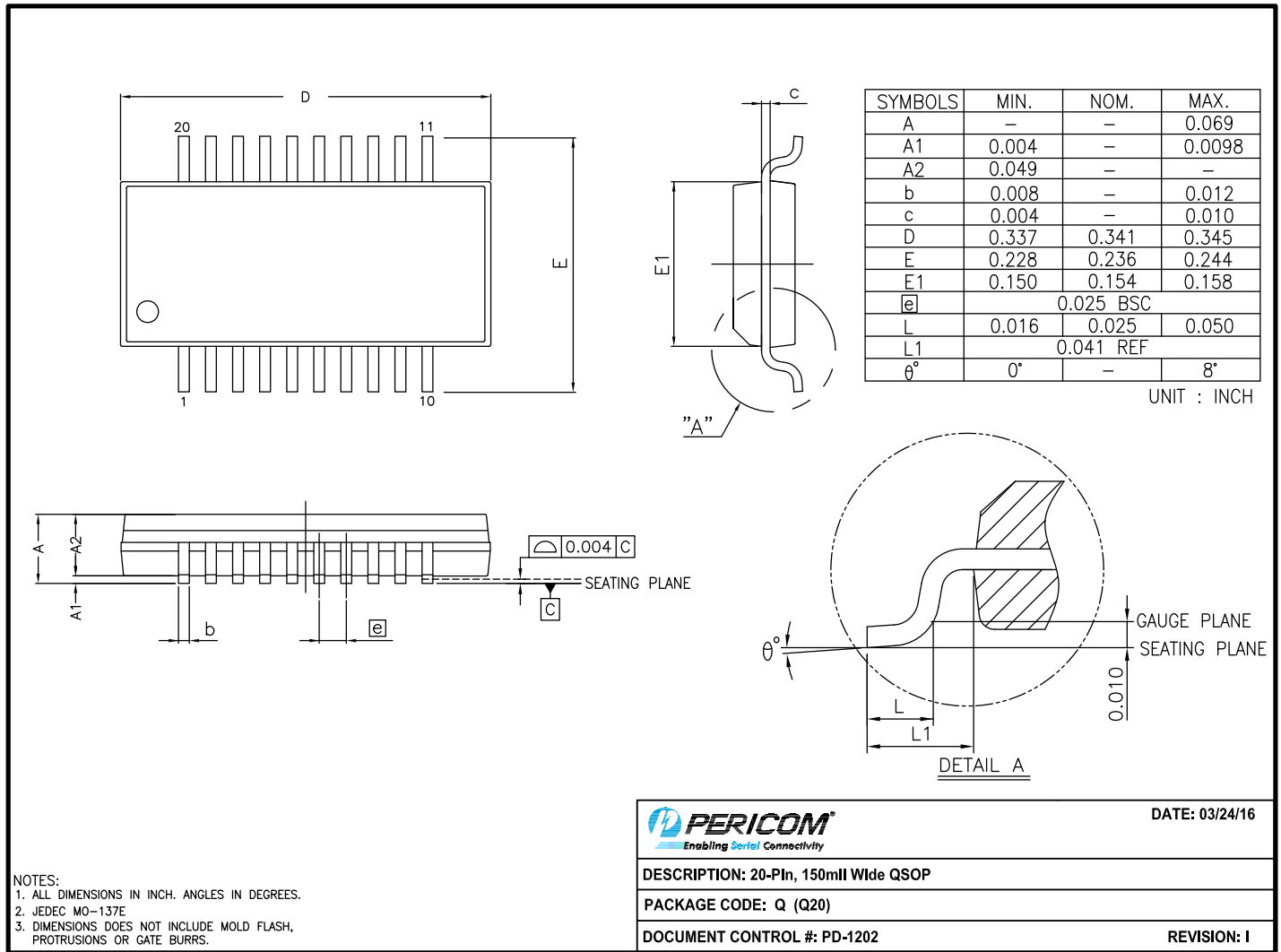

For latest package info.

please check: <http://www.diodes.com/design/support/packaging/pericom-packaging/packaging-mechanicals-and-thermal-characteristics/>

Ordering Information

Ordering Code	Package Code	Speed Grade	Package Description
PI49FCT3807BQEX	Q	B	20-pin 150-mil QSOP
PI49FCT3807CQEX	Q	C	20-pin 150-mil QSOP
PI49FCT3807DHEX	H	D	20-pin 209-mil SSOP
PI49FCT3807DQEX	Q	D	20-pin 150-mil QSOP
PI49FCT3807QEX	Q	Blank	20-pin 150-mil QSOP

Notes:

1. No purposely added lead. Fully EU Directive 2002/95/EC (RoHS), 2011/65/EU (RoHS 2) & 2015/863/EU (RoHS 3) compliant.
2. See <https://www.diodes.com/quality/lead-free/> for more information about Diodes Incorporated's definitions of Halogen- and Antimony-free, "Green" and Lead-free.
3. Halogen- and Antimony-free "Green" products are defined as those which contain <900ppm bromine, <900ppm chlorine (<1500ppm total Br + Cl) and <1000ppm antimony compounds.
4. E = Pb-free and Green
5. X suffix = Tape/Reel