

## Features

- Operates as a 4-bit GTL-/GTL/GTL+ to GTL-/GTL/GTL+ bus buffer
- 2.3 V to 3.6 V operation
- GTL input and output 3.6 V tolerant
- Vref adjustable from 0.5 V to VCC/2
- Partial power-down permitted
- ESD protection exceeds 2000 V HBM per JESD22-A114 and 1000 V CDM per JESD22-CC101
- Latch-up protection exceeds 200 mA per JESD78
- Package offered: TSSOP14

## Pin Configuration

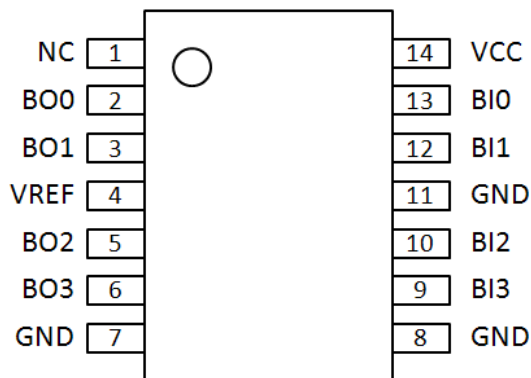

## Description

The GTL2034 is a 4-bit GTL-/GTL/GTL+ bus buffer. The GTL2034 GTL inputs and outputs operate up to 3.6 V, allowing the device to be used in higher voltage open-drain output applications.

## Pin Description

NC	1	not connected
BO0	2	data outputs (GTL)
BO1	3	
BO2	5	
BO3	6	
BI0	13	data inputs (GTL)
BI1	12	
BI2	10	
BI3	9	
VREF	4	GTL reference voltage
GND	7,8,11	ground (0 V)
VCC	14	positive supply voltage

**Block Diagram**

Figure 1: Block diagram

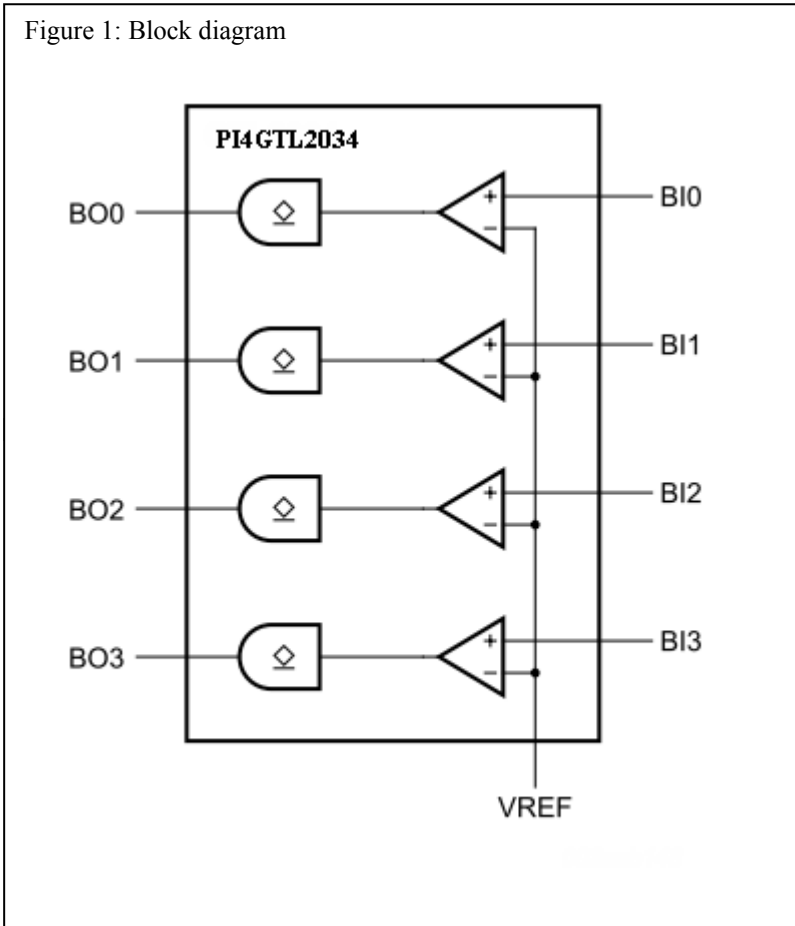

**Function Table:**

BIx	BOx
Input	Output

## Maximum Ratings

Power supply.....	-0.5V to +4.6V
Voltage on an I/O pin.....	GND-0.5V to +4.6V
Supply current.....	±160mA
Ground supply current.....	400mA
Total power dissipation.....	200mW
Operation temperature.....	-40~85°C
Storage temperature.....	-65~150°C
Maximum Junction temperature, T <sub>j(max)</sub> .....	125°C
Total power dissipation.....	200mW

### Note:

Stresses greater than those listed under MAXIMUM RATINGS may cause permanent damage to the device. This is a stress rating only and functional operation of the device at these or any other conditions above those indicated in the operational sections of this specification is not implied. Exposure to absolute maximum rating conditions for extended periods may affect reliability.

## Limiting Values

Symbol	Parameter	Conditions	Min.	Max.	Unit
VCC	Supply voltage		-0.5	4.6	V
I <sub>IK</sub>	Input clamping current	V <sub>I</sub> < 0V	-	-50	mA
V <sub>I</sub>	Input voltage	B port	-0.5 <sup>[1]</sup>	4.6	V
I <sub>OK</sub>	Output clamping current	V <sub>O</sub> < 0V	-	-50	mA
V <sub>O</sub>	Output voltage	output in OFF or HIGH state B port	-0.5 <sup>[1]</sup>	4.6	V
I <sub>OL</sub>	LOW-level output current	B port	-	80	mA
T <sub>stg</sub>	Storage temperature		<sup>[2]</sup> -60	150	°C

Note:

- [1] The input and output negative voltage ratings may be exceeded if the input and output clamp current ratings are observed.
- [2] The performance capability of a high-performance integrated circuit in conjunction with its thermal environment can create junction temperatures which are detrimental to reliability. The maximum junction temperature of this integrated circuit should not exceed 150 °C.

### Operating Conditions

Symbol	Parameter	Conditions	Min.	Typ.	Max.	Unit
VCC	Supply voltage		2.3	-	3.6	V
V <sub>TT</sub>	Termination voltage <sup>[1]</sup>	Lowest voltage	0.71	0.75	0.79	V
		GTL-	0.85	0.9	0.95	V
		GTL	1.14	1.2	1.26	V
		GTL+	1.35	1.5	1.65	V
V <sub>ref</sub>	Reference voltage	overall	0.43	2/3V <sub>TT</sub>	VCC/2	V
		Lowest voltage	0.43	0.5	0.55	
		GTL-	0.5	0.6	0.63	V
		GTL	0.76	0.8	0.84	V
		GTL+	0.87	1	1.1	V
V <sub>I</sub>	Input voltage	B port	0	V <sub>TT</sub>	3.6	V
V <sub>IH</sub>	HIGH-level input voltage	B port	V <sub>ref</sub> + 0.050	-	-	V
V <sub>IL</sub>	LOW-level input voltage	B port	-	-	V <sub>ref</sub> - 0.050	V
I <sub>OL</sub>	LOW-level output current	B port	-	-	40	mA
T <sub>amb</sub>	Ambient temperature	operating in free-air	-40	-	-85	°C

Note:

[1] V<sub>TT</sub> maximum of 3.6 V with resistor sized so I<sub>OL</sub> maximum is not exceeded.

### Static Characteristics

Recommended operating conditions; voltages are referenced to GND (ground = 0 V). T<sub>amb</sub> = -40 °C to +85 °C

Symbol	Parameter	Conditions	Min.	Typ. <sup>[1]</sup>	Max.	Unit
V <sub>OL</sub>	LOW-level output voltage	B port; VCC = 3.0 V; I <sub>OL</sub> = 40 mA		0.23	0.4	V
		B port; VCC = 2.3 V; I <sub>OL</sub> = 40 mA		0.26	0.4	V
I <sub>I</sub>	Input current	B port; VCC = 3.6 V; V <sub>I</sub> = V <sub>TT</sub> or GND			±1	uA
I <sub>LO</sub>	Output leakage current	B port; VCC = 3.6 V; V <sub>O</sub> = V <sub>TT</sub>			±1	uA
ICC	Quiescent supply current	B port; VCC = 3.6 V; V <sub>I</sub> = VCC or GND; IO = 0 mA		4	8	mA
C <sub>i</sub>	Input capacitance	B port; V <sub>O</sub> = V <sub>TT</sub> or 0 V		4.5		pF
C <sub>o</sub>	Input/output capacitance	B port; V <sub>O</sub> = V <sub>TT</sub> or 0 V		5.5		pF

Note:

[1] All typical values are measured at VCC = 3.3 V and T<sub>amb</sub> = 25 °C.

[2] The input and output voltage ratings may be exceeded if the input and output current ratings are observed.

### Dynamic Characteristics

All typical values are at VCC = 3.3 V and Tamb = 25 ° C.

Symbol	Parameter	Conditions	Min.	Typ.	Max.	Unit
GTL - ; Vref = 0.5V; VTT = 0.75 V						
t <sub>PLH</sub>	LOW to HIGH propagation delay	BIn to BOn;		3.5	8	ns
t <sub>PHL</sub>	HIGH to LOW propagation delay	BIn to BOn;		6.5	10	ns
GTL - ; Vref = 0.6 V; VTT = 0.9 V						
t <sub>PLH</sub>	LOW to HIGH propagation delay	BIn to BOn;		3.5	8	ns
t <sub>PHL</sub>	HIGH to LOW propagation delay	BIn to BOn;		6.5	10	ns
GTL - ; Vref = 0.8 V; VTT = 1.2 V						
t <sub>PLH</sub>	LOW to HIGH propagation delay	BIn to BOn;		4.1	8	ns
t <sub>PHL</sub>	HIGH to LOW propagation delay	BIn to BOn;		6.5	10	ns
GTL+; Vref = 1.0 V; VTT = 1.5 V						
t <sub>PLH</sub>	LOW to HIGH propagation delay	BIn to BOn;		4.6	8	ns
t <sub>PHL</sub>	HIGH to LOW propagation delay	BIn to BOn;		6.5	10	ns

### Dynamic Characteristics

All typical values are at VCC = 2.5 V and Tamb = 25 ° C.

Symbol	Parameter	Conditions	Min.	Typ.	Max.	Unit
GTL - ; Vref = 0.5V; VTT = 0.75 V						
t <sub>PLH</sub>	LOW to HIGH propagation delay	BIn to BOn;		4.2	8	ns
t <sub>PHL</sub>	HIGH to LOW propagation delay	BIn to BOn;		8.6	12	ns
GTL - ; Vref = 0.6 V; VTT = 0.9 V						
t <sub>PLH</sub>	LOW to HIGH propagation delay	BIn to BOn;		4.4	8	ns
t <sub>PHL</sub>	HIGH to LOW propagation delay	BIn to BOn;		8.6	12	ns
GTL - ; Vref = 0.8 V; VTT = 1.2 V						
t <sub>PLH</sub>	LOW to HIGH propagation delay	BIn to BOn;		5.3	9	ns
t <sub>PHL</sub>	HIGH to LOW propagation delay	BIn to BOn;		8.9	13	ns
GTL+; Vref = 1.0 V; VTT = 1.5 V						
t <sub>PLH</sub>	LOW to HIGH propagation delay	BIn to BOn;		6.5	10	ns
t <sub>PHL</sub>	HIGH to LOW propagation delay	BIn to BOn;		9.4	14	ns

**Waveforms**

$V_M = V_{ref}$  for B ports

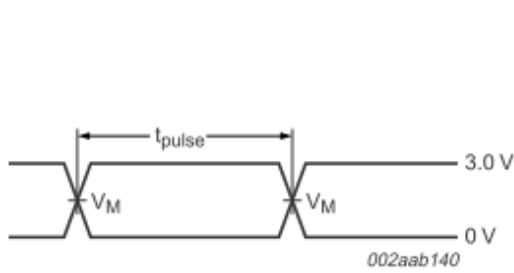

a. Pulse duration

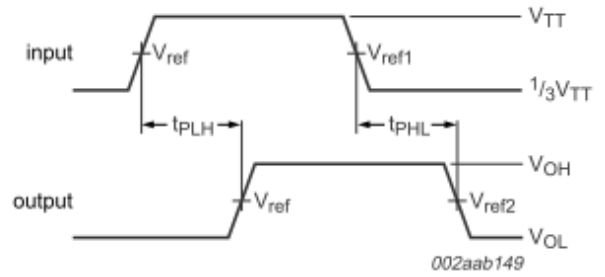

b. Propagation delay times

Fig 2. Voltage waveforms

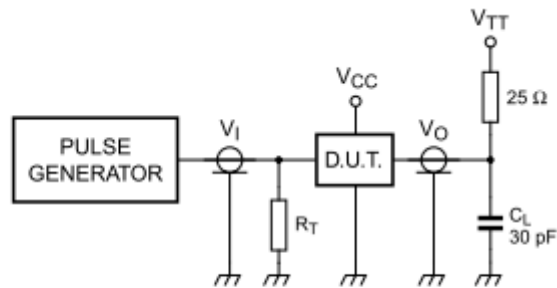

$C_L$  = load capacitance; includes jig and probe capacitance.

$R_T$  = termination resistance; should be equal to  $Z_o$  of pulse generator.

Fig 3. Load circuit for B outputs

**Part Marking**

L Package



YY: Year

WW: Workweek

1st X: Assembly Code

2nd X: Fab Code

**Package Mechanical:**  
TSSOP-14(L)

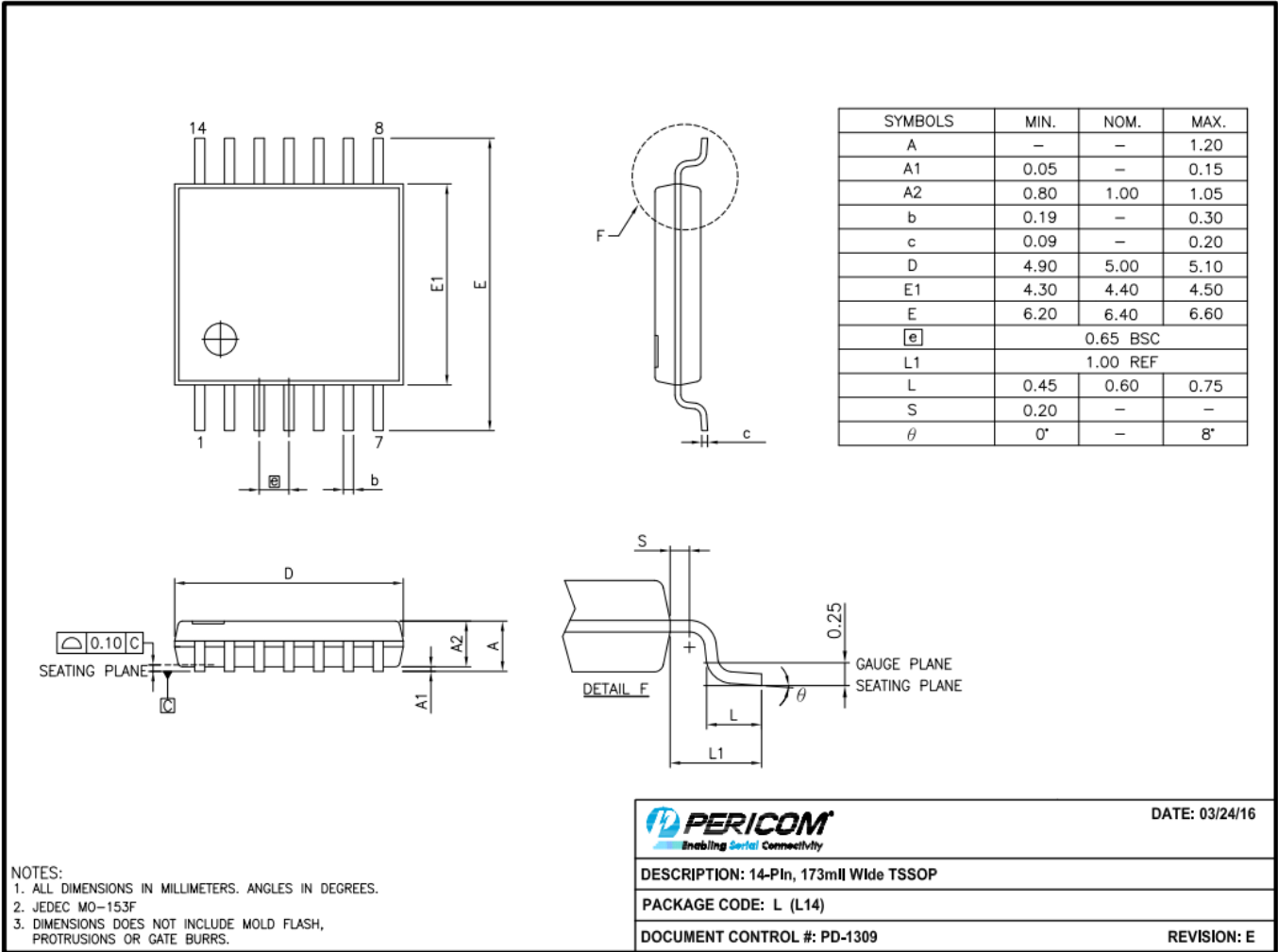

**For latest package info.**

please check: <http://www.diodes.com/design/support/packaging/pericom-packaging/packaging-mechanicals-and-thermal-characteristics/>

**Ordering Information**

Part No.	Package Code	Description
PI4GTL2034LEX	L	14-Pin, 173 mil Wide (TSSOP)

**Notes:**

- Thermal characteristics can be found on the company web site at [www.diodes.com/design/support/packaging/](http://www.diodes.com/design/support/packaging/)
- E = Pb-free and Green
- X suffix = Tape/Reel