

Hot Swappable I2C Bus/SMBus Buffer

Features

- ➔ Bidirectional Buffer for SDA and SCL Lines Increases Fan Out
- ➔ Prevents SDA and SCL Corruption During Live Board Insertion and Removal from Backplane
- ➔ Isolates Input SDA and SCL Lines From Output
- ➔ Compatible with I2C, I2C Fast Mode, and SMBus Standards (up to 400kHz Operation)
- ➔ Built-in Rise-Time Accelerators on all SDA and SCL
- ➔ Wide Supply Voltage Range: 2.7V to 5.5V
- ➔ Active HIGH ENABLE Input
- ➔ Active HIGH READY Open-Drain Output
- ➔ High-Impedance SDA and SCL pins for VCC = 0V
- ➔ 1.1V Pre-Charge on all SDA and SCL Lines
- ➔ Supporting Clock Stretching and Multiple Master Arbitration/Synchronization
- ➔ ESD Protection Exceeds 4000V HBM per JESD22-A114
- ➔ Packages Offered: MSOP-8(U), UDFN-8(ZW), and SOIC-8(W)
- ➔ **Totally Lead-Free & Fully RoHS Compliant (Notes 1 & 2)**
- ➔ **Halogen and Antimony Free. “Green” Device (Note 3)**

Pin Configuration

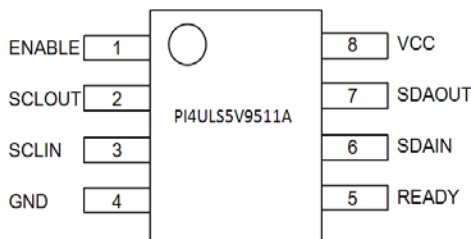

Figure 1. Top View of MSOP-8 and SOIC-8

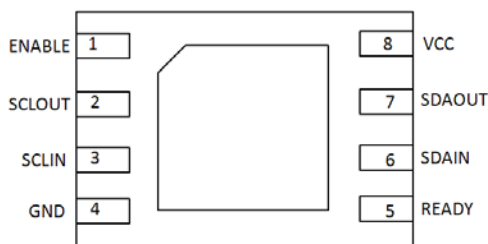

Figure 2. Top View of UDFN 2x3-8

Description

The PI6ULS5V9511A is a hot-swappable I2C-bus and SMBus buffer that allows I/O card insertion into a live backplane without corrupting the data and clock buses. Control circuitry prevents the backplane from connecting to the card until a stop command or bus idle occurs on the backplane without bus contention on the card.

When the connection is made, the PI6ULS5V-9511A provides bidirectional buffering, which keeps the backplane and card capacitances isolated.

The PI6ULS5V9511A rise-time accelerator circuitry allows the use of weaker DC pullup currents while still meeting rise-time requirements. The PI6ULS5V9511A incorporates a digital ENABLE input pin, which enables the device when asserted HIGH and forces the device into a low-current mode when asserted LOW, and an open-drain READY output pin, which indicates that the backplane and card sides are connected together (HIGH) or not (LOW).

During insertion, the PI6ULS5V9511A SDA and SCL lines are pre-charged to 1.1V to minimize the current required to charge the parasitic capacitance of the chip.

Pin Description

Pin Name	Pin No.	Description
ENABLE	1	Chip enable.
SCLOUT	2	Serial clock output to and from the SCL bus on the card
SCLIN	3	Serial clock input to and from the SCL bus on the backplane
GND	4	Ground. Connect this pin to a ground plane for best results.
READY	5	Open-drain output . Goes LOW when SDA/SCL channels are disconnected. Goes HIGH when the two sides are connected.
SDAIN	6	Serial data input to and from the SDA bus on the backplane.
SDAOUT	7	Serial data output to and from the SDA bus on the card.
VCC	8	Power supply.

Notes: 1. No purposely added lead. Fully EU Directive 2002/95/EC (RoHS), 2011/65/EU (RoHS 2) & 2015/863/EU (RoHS 3) compliant.
 2. See <https://www.diodes.com/quality/lead-free/> for more information about Diodes Incorporated's definitions of Halogen- and Antimony-free, "Green" and Lead-free.
 3. Halogen- and Antimony-free "Green" products are defined as those which contain <900ppm bromine, <900ppm chlorine (<1500ppm total Br + Cl) and <1000ppm antimony compounds.

Block Diagram

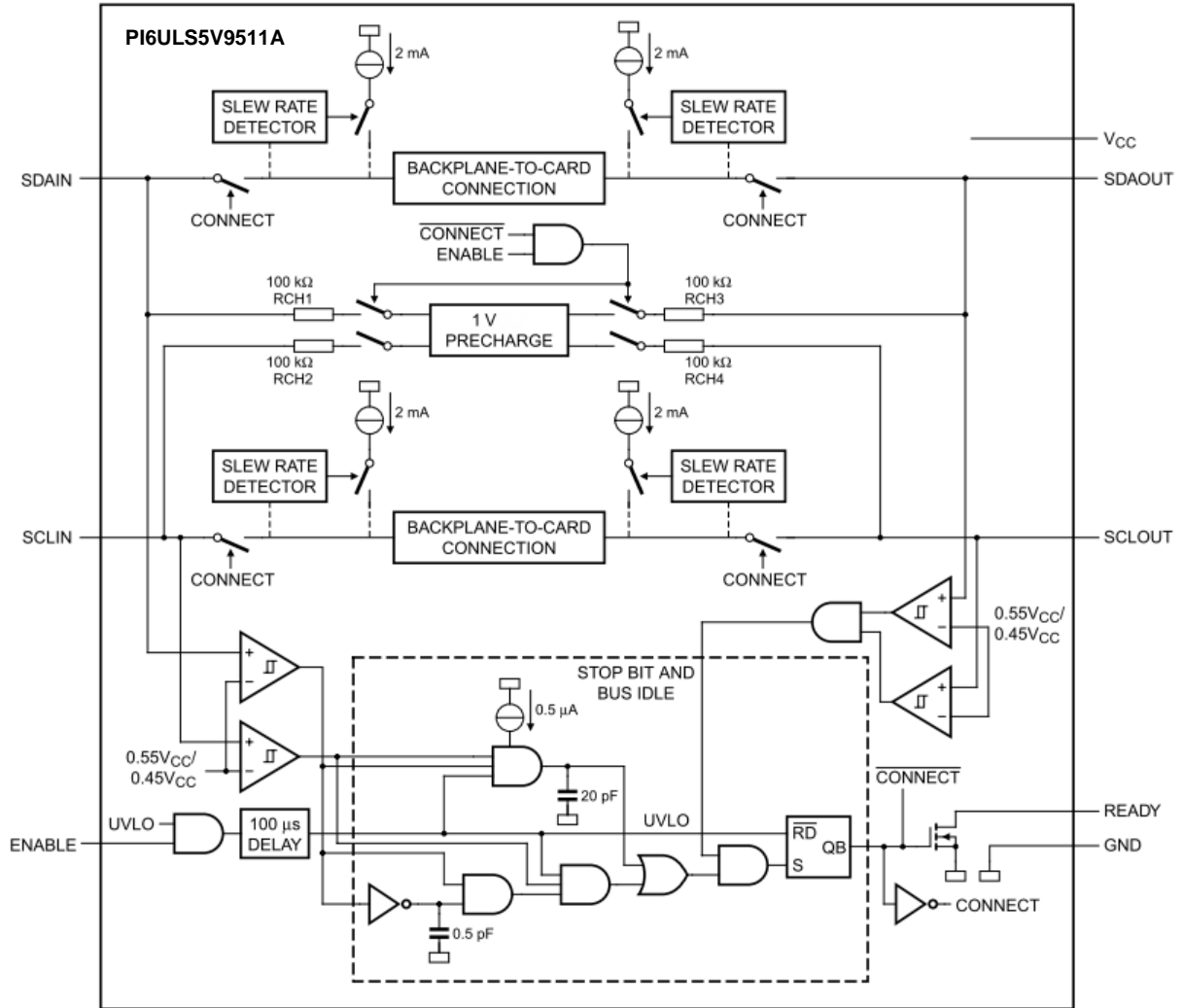

Figure 3: Block Diagram

Maximum Ratings

Supply Voltage	-0.5V to +6.0V
DC Input Voltage	-0.5V to +6V
Control Input Voltage (EN)	-0.5V to +6V
Total Power Dissipation ⁽¹⁾	100mW
Input/Output Current (Port 0 & 1).....	0mA
Input Current (EN , VCC, GND).....	50mA
ESD: HBM Mode	4000V
Storage Temperature	-55°C to +125°C

Note:

Stresses greater than those listed under MAXIMUM RATINGS may cause permanent damage to the device. This is a stress rating only and functional operation of the device at these or any other conditions above those indicated in the operational sections of this specification is not implied. Exposure to absolute maximum rating conditions for extended periods may affect reliability.

Recommended Operating Conditions

VCC = 2.7V to 5.5V; GND = 0V; Tamb = -40°C to +85°C; unless otherwise specified

Symbol	Parameter	CONDITIONS	Min.	TYP	Max.	Unit
V _{CC} ^[1]	Supply Voltage Port B	—	2.7	—	5.5	V
I _{CC}	Supply Current	VCC = 5.5V; VSDAIN = VSCLIN = 0V	—	2.8	6	mA
I _{CC(sd)}	Shut-Down Mode Supply Current	VENABLE = 0V; All Other pins at VCC or GND	—	0.1	—	μA

Note: 1. This specification applies over the full operating temperature range.

Electrical Characteristics

VCC = 2.7 V to 5.5 V; GND = 0 V; Tamb = -40°C to +85°C; unless otherwise specified

Parameter	Description	Test Conditions	Min	Typ.	Max	Unit
Startup Circuitry						
V _{pch} ^[1]	Pre-Charge Voltage	SDA, SCL Floating	0.8	1.1	1.2	V
V _{IH(ENABLE)}	HIGH-Level Input Voltage on pin ENABLE	—	—	0.5 × V _{CC}	0.7 × V _{CC}	V
V _{IL(ENABLE)}	LOW-Level Input Voltage on pin ENABLE	—	0.3 × V _{CC}	0.5 × V _{CC}	—	V
I _{I(ENABLE)}	Input Current on pin ENABLE	V _{ENABLE} = 0V to V _{CC}	—	±0.1	±1	μA
t _{en} ^[2]	Enable Time	—	—	110	—	μs
t _{idle(READY)} ^[1]	Bus Idle Time to READY Active	—	50	105	200	μs
t _{dis(EN-RDY)}	Disable Time (ENABLE to READY)	—	—	30	—	ns
t _{stp(READY)} ^[3]	SDAIN to READY Delay After STOP	—	—	1.2	—	μs
t _{READY} ^[3]	SCLOUT/SDAOUT to READY delay	—	—	0.8	—	μs
I _{LZ(READY)}	Off-State Leakage Current on pin READY	V _{ENABLE} = V _{CC}	—	±0.3	—	μA
C _{i(ENABLE)} ^[4]	Input Capacitance on pin ENABLE	V _I = V _{CC} or GND	—	1.9	4.0	pF
C _{o(READY)} ^[4]	LOW-Level Output Voltage	V _I = V _{CC} or GND	—	2.5	4.0	pF
V _{OL(READY)} ^[1]	LOW-Level Output Voltage on pin READY	I _{pu} = 3mA; V _{ENABLE} = V _{CC}	—	—	0.4	V

- Note:
1. This specification applies over the full operating temperature range.
 2. The enable time can slow considerably for some parts when temperature is < -20°C.
 3. Delays that can occur after ENABLE and/or idle times have passed.
 4. Guaranteed by design, not production tested.
 5. I_{trt}(pu) varies with temperature and VCC voltage.
 6. Input pullup voltage must not exceed power supply voltage in operating mode because the rise time accelerator will clamp the voltage to the positive supply rail.
 7. The connection circuitry always regulates its output to a higher voltage than its input.
 8. Force V_{SDAIN} = V_{SCLIN} = 0.1V, tie SDAOUT and SCLOUT through 10kΩ resistor to VCC and measure the SDAOUT and SCLOUT output.

Electrical Characteristics (continued)

V_{CC} = 2.7 V to 5.5 V; GND = 0 V; T_{amb} = -40°C to +85°C; unless otherwise specified

Parameter	Description	Test Conditions	Min	Typ.	Max	Unit
Rise Time Accelerators						
I _{trt(pu)} [5][6]	Transient Boosted Pullup Current	Positive Transition on SDA, SCL; V _{CC} = 2.7V; Slew Rate = 1.25V/μs	1	2	—	V
Input-Output Connection						
V _{offset} [1][7][8]	Offset Voltage	10kΩ to V _{CC} on SDA, SCL; V _{CC} = 3.3V	—	110	175	mV
t _{PLH}	LOW to HIGH Propagation Delay	SCL to SCL and SDA to SDA; 10kΩ to V _{CC} ; C _L = 100pF Each Side	—	0	—	ns
t _{PHL}	HIGH to LOW Propagation Delay	SCL to SCL and SDA to SDA; 10kΩ to V _{CC} ; C _L = 100pF Each Side	—	70	—	ns
C _{i(SCL/SDA)} [4]	SCL and SDA Input Capacitance	—	—	5	7	pF
V _{OL} [1]	LOW-Level Output Voltage	V _I = 0V; SDA _n , SCL _n pins; I _{sink} = 3mA; V _{CC} = 2.7V	0	—	0.4	V
I _{LI}	Input Leakage Current	SDA _n , SCL _n pins; V _{CC} = 5.5V	-1	—	+1	μA

- Note:
1. This specification applies over the full operating temperature range.
 2. The enable time can slow considerably for some parts when temperature is < -20°C.
 3. Delays can occur after ENABLE and/or idle times have passed.
 4. Guaranteed by design, not production tested.
 5. I_{trt(pu)} varies with temperature and V_{CC} voltage.
 6. Input pullup voltage must not exceed power supply voltage in operating mode because the rise time accelerator will clamp the voltage to the positive supply rail.
 7. The connection circuitry always regulates its output to a higher voltage than its input.
 8. Force V_{SDAIN} = V_{SCLIN} = 0.1V, tie SDAOUT and SCLOUT through 10kΩ resistor to V_{CC} and measure the SDAOUT and SCLOUT output.

I2C Interface Timing Requirements

Symbol	Parameter	Standard Mode I2C Bus		Fast Mode I2C Bus		Unit
		Min	Max	Min	Max	
f _{SCL}	I2C Clock Frequency	0	100	0	400	kHz
t _{Low}	I2C Clock High Time	4.7	—	1.3	—	μs
t _{High}	I2C Clock Low Time	4	—	0.6	—	μs
t _{SP}	I2C Spike Time	—	50	—	50	ns
t _{SU:DAT}	I2C Serial-Data Setup Time	250	—	100	—	ns
t _{HD:DAT}	I2C Serial-Data Hold Time	0 ^[1]	—	0 ^[1]	—	μs
t _r	I2C Input Rise Time	—	1000	—	300	ns
t _f	I2C Input Fall Time	—	300	—	300	ns
t _{BUF}	I2C Bus Free Time Between Stop and Start	4.7	—	1.3	—	μs
t _{SU:STA}	I2C Start or Repeated Start Condition Setup	4.7	—	0.6	—	μs
t _{HD:STA}	I2C Start or Repeated Start Condition Hold	4	—	0.6	—	μs
t _{SU:STO}	I2C Stop Condition Setup	4	—	0.6	—	μs
t _{VD:DAT}	Valid-Data Time (High to Low) ^[2] SCL Low to SDA Output Low Valid	—	1	—	1	μs
	Valid-Data Time (Low to High) ^[2] SCL Low to SDA Output High Valid	—	0.6	—	0.6	μs
t _{VD:ACK}	Valid-Data Time of ACK Condition ACK Signal From SCL Low to SDA Output Low	—	1	—	1	μs
C _b	I2C Bus Capacitive Load	—	400	—	400	pF

Notes: 1. A device internally must provide a hold time of at least 300ns for the SDA signal (referred to as the VIH min of the SCL signal) in order to bridge the undefined region of the falling edge of SCL.
2. Data taken using a 1kΩ pullup resistor and 50pF load notes

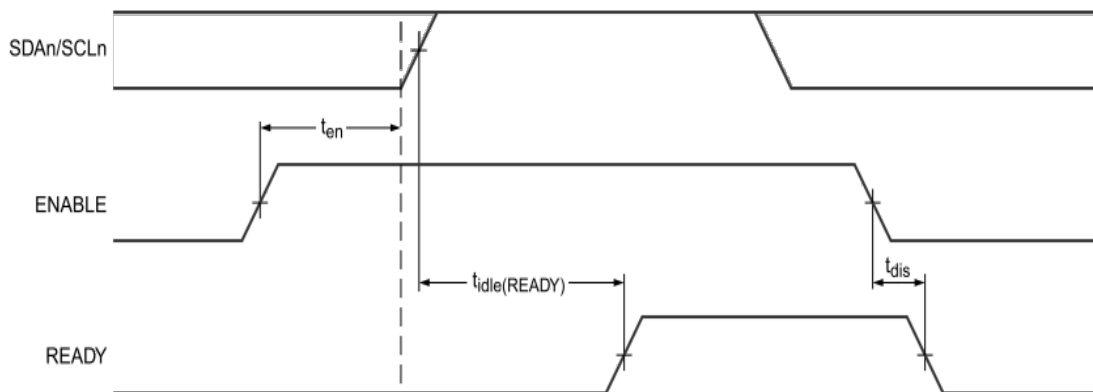
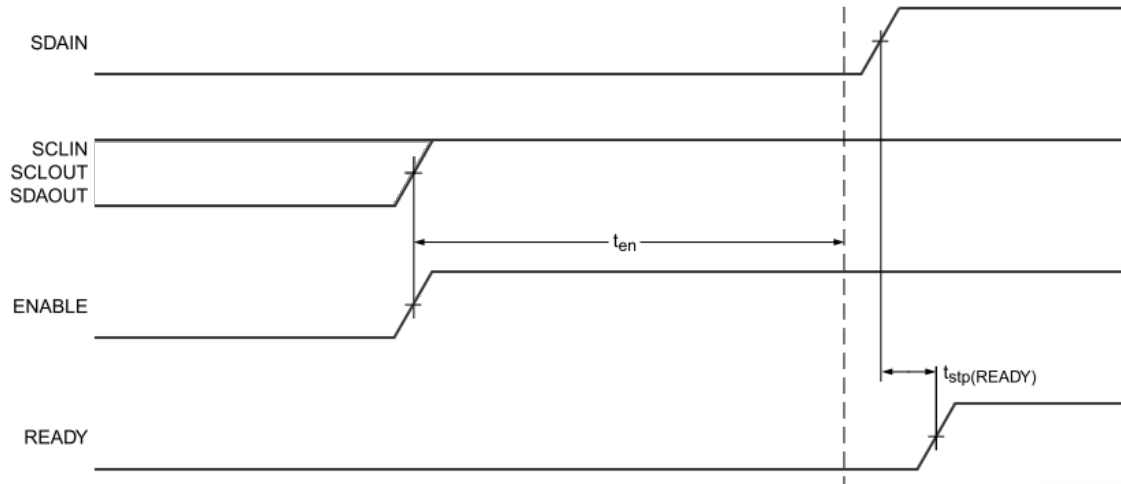
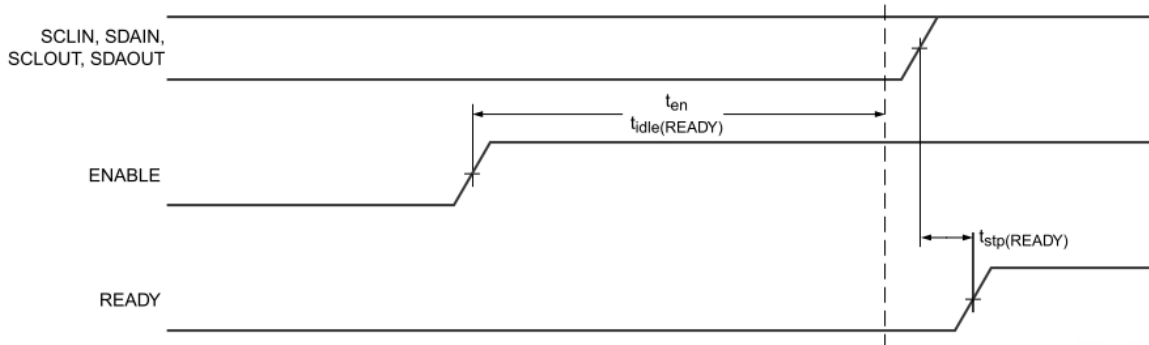

Figure 4. Timing for t_{en}, t_{idle(READY)} and t_{dis}



$t_{stp(READY)}$ is only applicable after the t_{en} delay.

Figure 5. $t_{stp(READY)}$ that can Occur After t_{en}



$t_{stp(READY)}$ is only applicable after the t_{en} delay.

Figure 6. $t_{stp(READY)}$ Delay that can Occur After T_{en} and $t_{idle(READY)}$

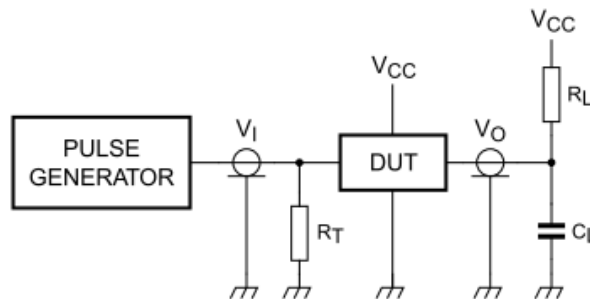

R_L = load resistor; 1.35 k Ω

C_L = load capacitance includes jig and probe capacitance; 50 pF

R_T = termination resistance should be equal to Z_o of pulse generators

Figure 7: Test Circuitry for Switching Times

Function Description

Startup

An undervoltage/initialization circuit holds the parts in a disconnected state, which presents high-impedance to all SDA and SCL pins during power-up. A LOW on the ENABLE pin also forces the parts into the low-current disconnected state when the ICC is essentially zero. When the power supply is brought up, and the ENABLE is HIGH, or when the part is powered and the ENABLE is taken from LOW to HIGH, the device enters an initialization state where the internal references are stabilized, and the pre-charge circuit is enabled.

At the end of the initialization state, the *Stop Bit And Bus Idle* detect circuit is enabled. SDAIN is connected to SDAOUT, and SCLIN is connected to SCLOUT when the ENABLE pin is HIGH long enough to complete the initialization state (ten) and remains HIGH while all of the SDA and SCL pins are HIGH for the bus idle time or when all pins are HIGH, and a STOP condition is on the SDAIN and SCLIN pins.

The 1V pre-charge circuitry is activated during the initialization and is deactivated when the connection is made. The pre-charge circuitry pulls up the SDA and SCL pins to 1V through individual 100k Ω nominal resistors. This pre-charges the pins to 1V to minimize the worst-case disturbances that result from inserting a card into the backplane where the backplane and the card are at opposite logic levels.

Connect Circuitry

Once the connection circuitry is activated, the behavior of SDAIN and SDAOUT as well as SCLIN and SCLOUT become identical with each pin acting as a bidirectional buffer that isolates the input capacitance from the output bus capacitance while communicating the logic levels.

A LOW forced on either SDAIN or SDAOUT causes the other pin to be driven to a LOW by the part. The same is also true for the SCL pins. Noise between 0.7VCC and VCC is generally ignored because a falling edge is only recognized when it falls below 0.7VCC with a slew rate of at least 1.25 V/ μ s. When a falling edge is on one pin, the other pin in the pair turns on a pulldown driver that is referenced to a small voltage above the falling pin. The driver pulls the pin down at a slew rate initially determined by the driver and the load because the driver does not start until the first falling pin is below 0.7VCC. The first falling pin can have a fast or slow slew rate. If the falling pin is faster than the pulldown slew rate, the initial pulldown rate continues. If the first falling pin has a slow slew rate, the second pin is pulled down at its initial slew rate until it is just above the first pin's voltage then both pins continue down at the slew rate of the first pin.

When both sides are LOW, they remain LOW until all of the external drivers stop driving LOWs. If both sides are driven LOW to the same value—for instance, 10 mV—by external drivers, which is the case for clock stretching and is typically the case for acknowledge, one side external driver stops driving that pin and rises until the internal driver pulls it down to the offset voltage. When the last external driver stops driving a LOW, the pin rises up and settles out just above the other pin as both rise together with a slew rate determined by the internal slew rate control and the RC time constant. As long as the slew rate is at least 1.25V/ μ s when the pin voltage exceeds 0.6V for the PI6ULS5V9511A, the rise-time accelerator's circuits turn on, and the pulldown driver turns off.

Maximum Number of Devices in Series

Each buffer adds about 0.1V dynamic level offset at 25°C with the offset larger at higher temperatures. Maximum offset (V_{offset}) is 0.150V with a 10kΩ pullup resistor. The LOW level at the signal origination end (master) is dependent upon the load, and the only specification point is that the I2C-bus specification of 3mA produces $V_{\text{OL}} < 0.4\text{V}$; although if lightly loaded, the V_{OL} may be ~0.1V. Assuming $V_{\text{OL}} = 0.1\text{V}$ and $V_{\text{offset}} = 0.1\text{V}$, the level after four buffers is 0.5 V, which is only about 0.1V below the threshold of the rising edge accelerator (about 0.6V). With great care a system with four buffers can work, but as the V_{OL} moves up from 0.1V, noise or bounces on the line results in firing the rising edge accelerator thus introducing false clock edges. Generally it is recommended to limit the number of buffers in series to two and to keep the load light to minimize the offset.

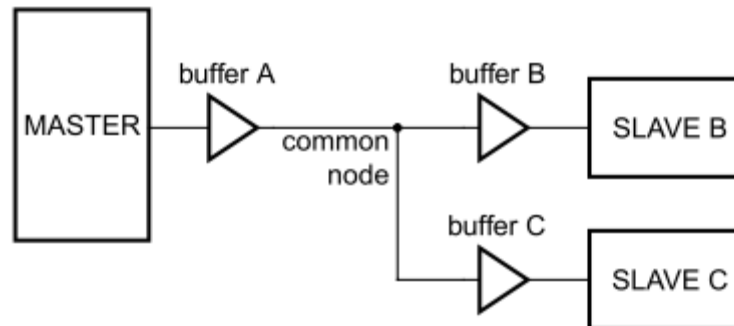

Figure 8: System with Three Buffers Connected to Common Node

Consider a system with three buffers connected to a common node and where communication between the Master and Slave B are connected at either end of buffer A and buffer B in series as shown in Figure 8. Consider if the V_{OL} at the input of buffer A is 0.3V, and the V_{OL} of Slave B (when acknowledging) is 0.4V with the direction changing from Master to Slave B and then from Slave B to Master. Before the direction change, V_{IL} at the input of buffer A is 0.3V, and its output, the common node, is ~0.4V. The output of buffer B and buffer C is ~0.5 V, but Slave B drives 0.4V, so the voltage at Slave B is 0.4V. The output of buffer C is ~0.5V.

When the Master pulldown turns off, the input of buffer A rises and so does its output, the common node, because it is the only part driving the node. The common node rises to 0.5V before buffer B's output turns on; if the pullup is strong, the node can bounce. If the bounce goes above the threshold for the rising edge accelerator ~0.6V, the accelerators on both buffer A and buffer C fire contending with the output of buffer B. The node on the input of buffer A will go HIGH as will the input node of buffer C. After the common node voltage is stable for a while, the rising edge accelerators turn off, and the common node returns to ~0.5V because the buffer B is still on. The voltage at both the Master and Slave C nodes fall to ~0.6V until Slave B turns off. This does not cause a failure on the data line as long as the return to 0.5V on the common node (~0.6V at the Master and Slave C) occurs before the data setup time. If this were the SCL line, the parts on buffer A and buffer C can detect a false clock rather than a stretched clock, which causes a system error.

Propagation Delays

The delay for a rising edge is determined by the combined pullup current from the bus resistors and the rise time accelerator current source and the effective capacitance on the lines. If the pullup currents are the same, any difference in rise time is directly proportional to the difference in capacitance between the two sides. The t_{PLH} can be negative if the output capacitance is less than the input capacitance and is positive if the output capacitance is larger than the input capacitance when the currents are the same. The t_{PHL} is never negative because the output does not start to fall until the input is below 0.7VCC, the output turn on has a non-zero delay, and the output has a limited maximum slew rate. Even if the input slew rate is slow enough that the output catches up, it still lags the falling voltage of the input by the offset voltage. The maximum t_{PHL} occurs when the input is driven LOW with zero delay, and the output is still limited by its turn-on delay and the falling edge slew rate. The output falling edge slew rate is a function of the internal maximum slew rate, which is a function of temperature, VCC, and process as well as the load current and the load capacitance.

Rise Time Accelerators

During positive bus transitions, a 2mA current source switches on to quickly slew the SDA and SCL lines HIGH once the input level of 0.6V for the PI6ULS5V9511A is exceeded. The rising edge rate must be at least 1.25V/ μ s to guarantee turnon of the accelerators.

The built-in $\Delta V/\Delta t$ rise-time accelerators on all SDA and SCL lines require the bus pullup voltage and supply voltage (VCC) to be the same.

READY Digital Output

This pin provides a digital flag, which is LOW when either ENABLE is LOW, or the start-up sequence described earlier in this section is not complete. READY goes HIGH when ENABLE is HIGH, and startup is complete. The pin is driven by an open-drain pulldown capable of sinking 3mA while holding 0.4V on the pin. Connect a resistor of 10k Ω to VCC to provide the pullup.

ENABLE Low-Current Disable

Grounding the ENABLE pin disconnects the backplane side from the card side, disables the rise-time accelerators, drives READY LOW, disables the bus pre-charge circuitry, and puts the part in a low-current state. When the pin voltage drives all the way to VCC, the part waits for data transactions on both the backplane and card sides to be complete before reconnecting the two sides.

Resistor Pullup Value Selection

In order to activate the boost pullup currents during rising edges, the system pullup resistors must be strong enough to provide a positive slew rate of 1.25V/ μ s on the SDA and SCL pins.. Choose a maximum resistor value using the following equation.

$$R \leq 800 \times 10^3 \left(\frac{VCC(\min) - 0.6}{C} \right)$$

Where:

- R is the pullup resistor value in Ω
- VCC(min) is the minimum VCC voltage in V
- C is the equivalent bus capacitance in pF)

In addition regardless of the bus capacitance, always choose $R \leq 65.7k\Omega$ for VCC = 5.5V maximum and $R \leq 45k\Omega$ for VCC = 3.6V maximum. The startup circuitry requires logic HIGH voltages on SDAOUT and SCLOUT to connect the backplane to the card. These pullup values are required to overcome the pre-charge voltage.

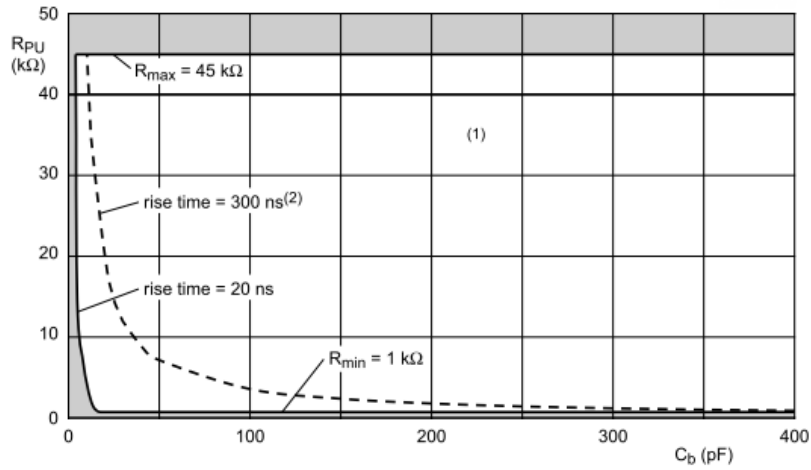

- Notes:
1. Unshaded area indicates recommended pullup, for rise time < 300 ns, with PI6ULS5V9511A.
 2. Rise time without PI6ULS5V9511A.

Figure 9. Bus Requirements for 3.3V Systems

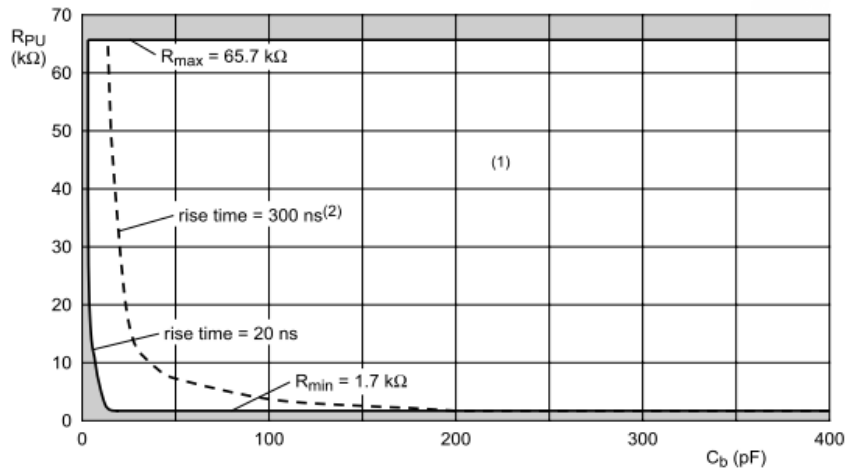

- Notes:
1. Unshaded area indicates recommended pullup, for rise time < 300 ns, with PI6ULS5V9511A.
 2. Rise time without PI6ULS5V9511A.

Figure 10. Bus Requirements for 5V Systems

Hot-Swapping and Capacitance Buffering Application

Figure 11 through Figure 14 illustrate the usage of the PI6ULS5V9511A in applications that take advantage of both its hot-swapping and capacitance buffering features. In all of these applications, note if the I/O cards are plugged directly into the backplane, all of the backplane and card capacitances add directly together, which makes rise-time and fall-time requirements difficult to meet. However, placing a bus buffer on the edge of each card isolates the card capacitance from the backplane. For a given I/O card, the PI6ULS5V9511A drives the capacitance of everything on the card, and the backplane must drive only the capacitance of the bus buffer, which is less than 10pF, the connector, trace, and all additional cards on the backplane.

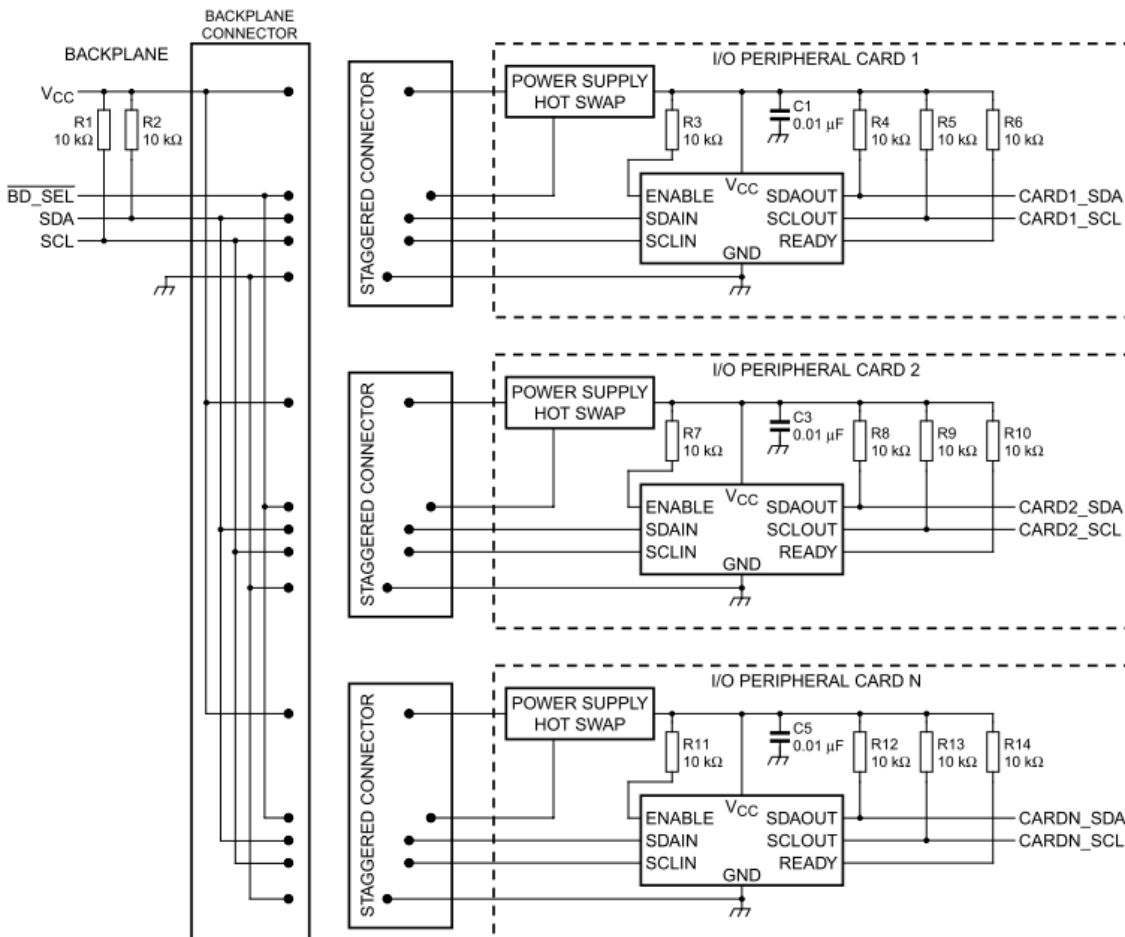

Note: The PI6ULS5V9511A can be used in any combination depending on the number of rise-time accelerators that are required by the system. Normally only one PI6ULS5V9511A is required per bus.

Figure 11. Hot Swapping Multiple I/O Cards into a Backplane Using the PI6ULS5V9511A in a cPCI, VME, and Advanced TCA System

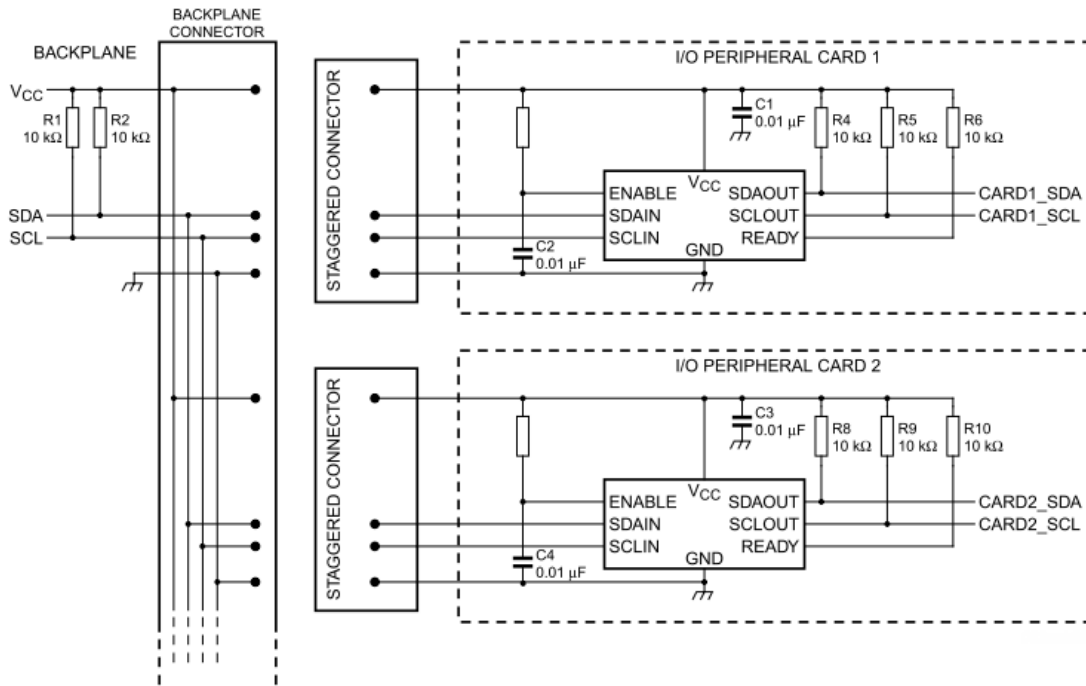

Figure 12. Hot Swapping Multiple I/O Cards into a Backplane Using PI6ULS5V9511A in a PCI System

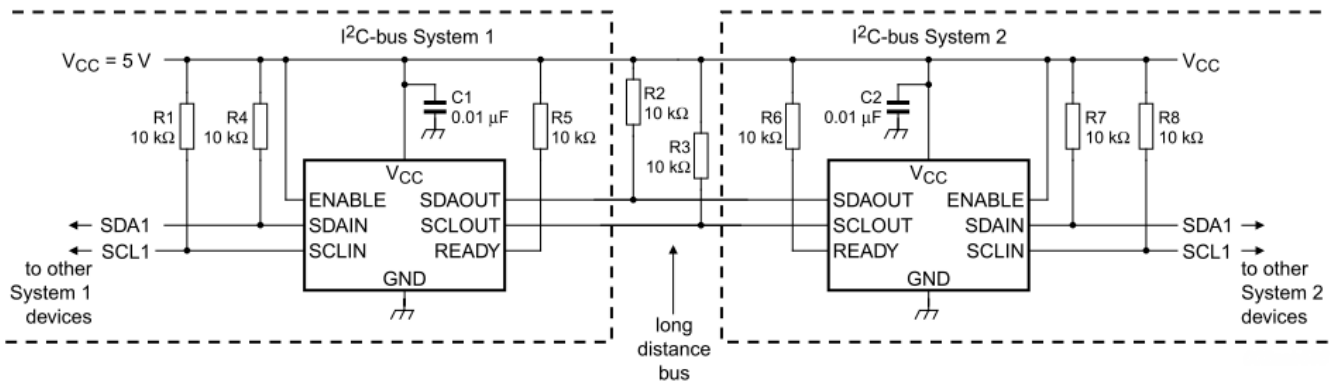
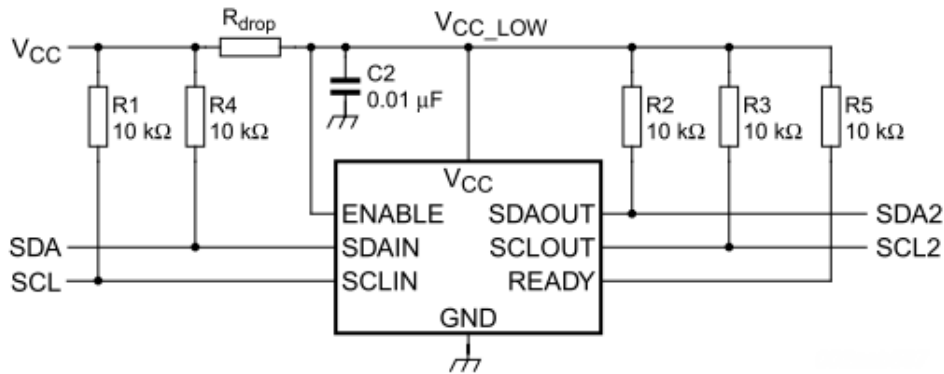

Figure 13. Repeater / Bus Extender Application Using PI6ULS5V9511A



$$V_{CC} > V_{CC_LOW}$$

R_{drop} is the line loss of V_{CC} in the backplane.

Figure 14. System with Disparate V_{CC} Voltages

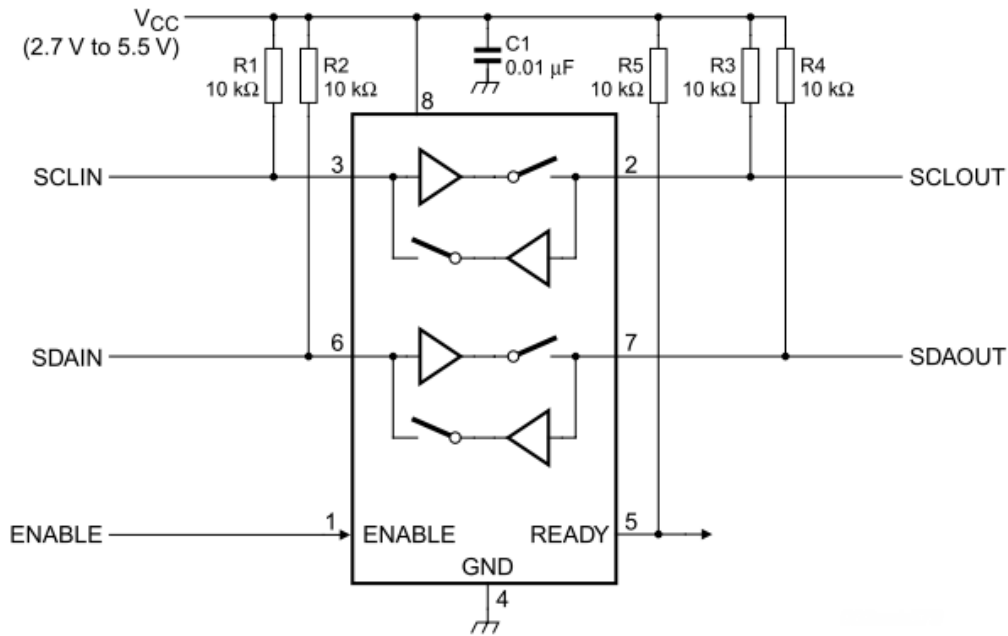

Figure 15. Typical A

Part Marking

U Package



Z: Die Rev
YW: Year & Work week
1st X: Assembly Code
2nd X: Wafer Fab site Code

W Package



Z: Die Rev
YW: Year & Work week
1st X: Assembly Code
2nd X: Wafer Fab site Code

ZW Package

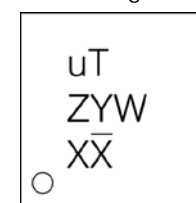

Z: Die Rev
YW: Year & Work week
1st X: Assembly Code
2nd X: Wafer Fab site Code

Packaging Mechanical
MSOP-8 (U)

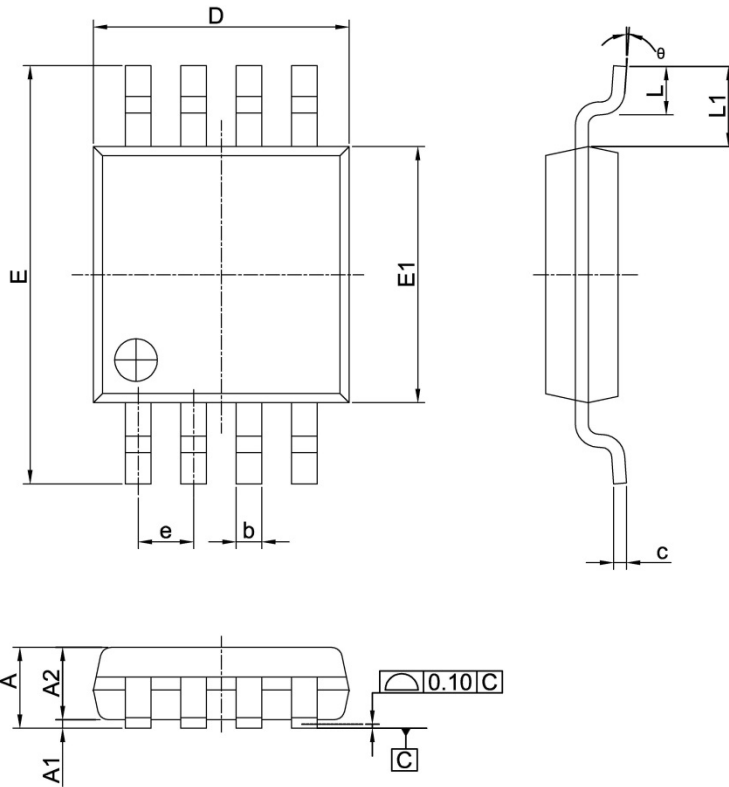

PKG DIMENSIONS(MM)		
SYMBOL	Min.	Max.
A	--	1.10
A1	0.00	0.15
A2	0.75	0.95
b	0.22	0.38
c	0.08	0.23
D	2.80	3.20
E	4.65	5.15
E1	2.80	3.20
e	0.65 BSC	
L	0.40	0.80
L1	0.95 REF	
θ	0°	8°

- NOTE:
 1. ALL DIMENSIONS ARE IN MILLIMETERS. ANGLES IN DEGREES.
 2. REFER JEDEC MO-187F/AA
 3. PACKAGE OUTLINE DIMENSIONS DO NOT INCLUDE MOLD FLASH AND METAL BURR.

DIODES INCORPORATED	PERICOM A PRODUCT LINE OF DIODES INCORPORATED ENABLING SERIAL CONNECTIVITY	DATE: 11/03/16
DESCRIPTION: 8-Pin, Mini Small Outline Package, MSOP		
PACKAGE CODE: U (U8)		
DOCUMENT CONTROL #: PD-1261	REVISION: G	

16-0242

SOIC-8 (W)

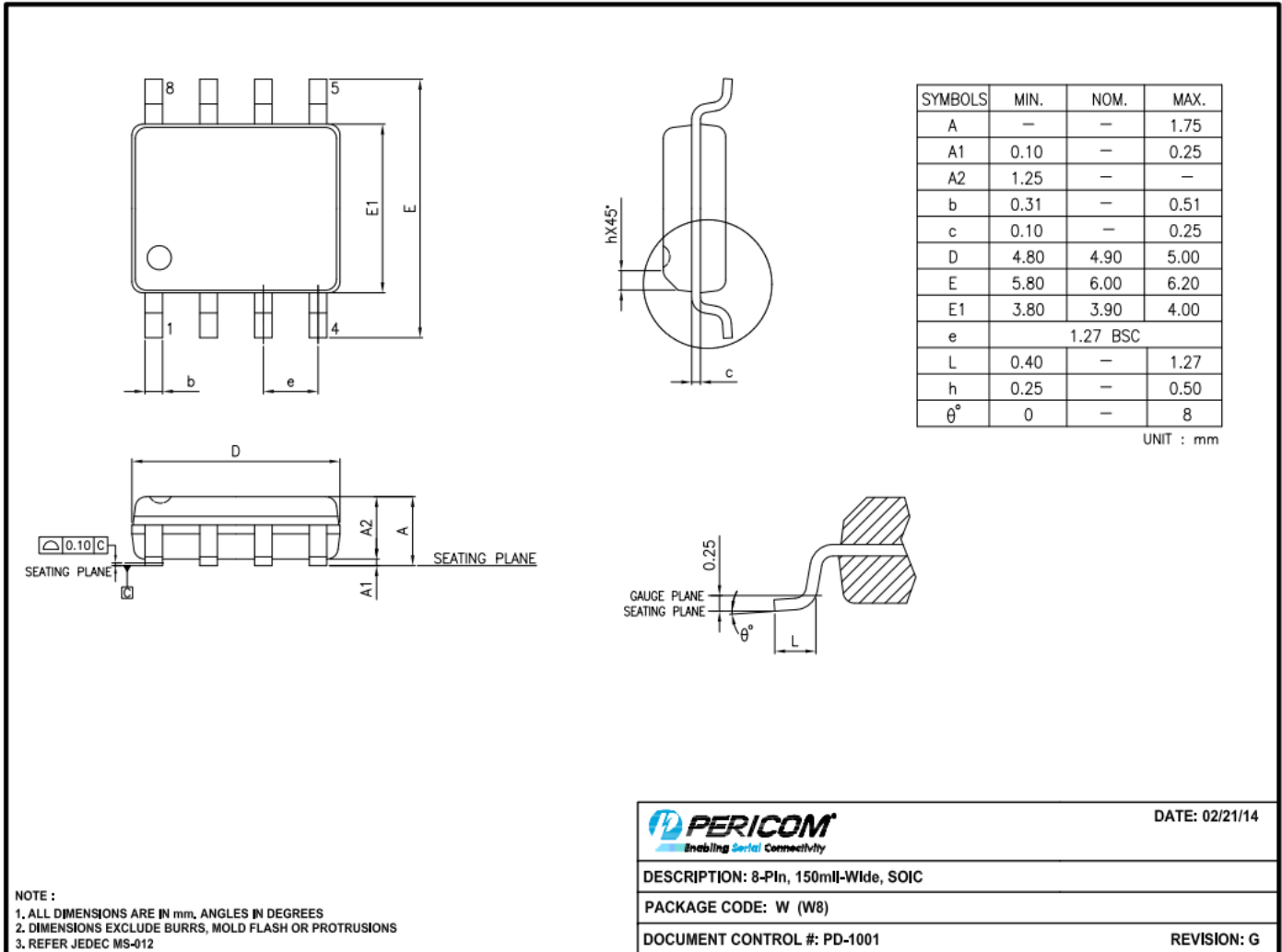

DATE: 02/21/14

DESCRIPTION: 8-Pin, 150mil-Wide, SOIC

PACKAGE CODE: W (W8)

DOCUMENT CONTROL #: PD-1001

REVISION: G

UDFN-8 (ZW)

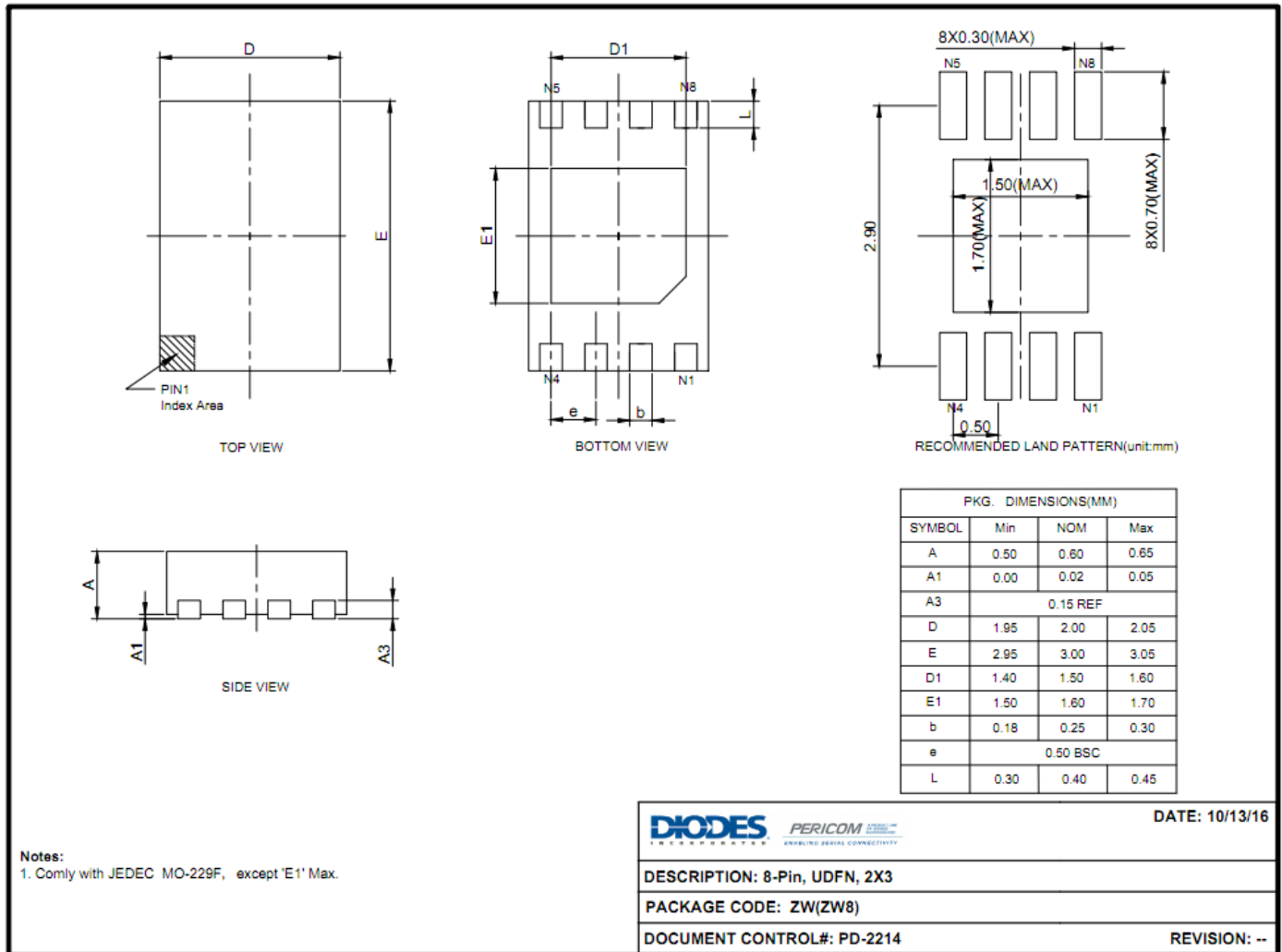

For latest package information:

Please see <http://www.diodes.com/design/support/packaging/pericom-packaging/packaging-mechanicals-and-thermal-characteristics/>.

Ordering Information

Part Numbers	Package Code	Package
PI6ULS5V9511AUEX	U	8-Pin, Mini Small Outline Package (MSOP)
PI6ULS5V9511AWEX	W	8-Pin, 150mil-Wide (SOIC)
PI6ULS5V9511AZWEX	ZW	8-Pin, 2x3 (UDFN)

- Notes:
1. No purposely added lead. Fully EU Directive 2002/95/EC (RoHS), 2011/65/EU (RoHS 2) & 2015/863/EU (RoHS 3) compliant.
 2. See <https://www.diodes.com/quality/lead-free/> for more information about Diodes Incorporated's definitions of Halogen- and Antimony-free, "Green" and Lead-free.
 3. Halogen- and Antimony-free "Green" products are defined as those which contain <900ppm bromine, <900ppm chlorine (<1500ppm total Br + Cl) and <1000ppm antimony compounds.
 4. E = Pb-free and Green
 5. X suffix = Tape/Reel