

PI90LV02A

SOTiny™ LVDS High-Speed Differential Line Receiver

Features

- Meets or Exceeds the Requirements of ANSI TIA/EIA-644-1995 Standard
- Signaling Rates Up to 680 Mbps
- Interfaces to LVDS, LVPECL
- Bus-Terminal ESD exceeds 2kV
- Differential Input Voltage Threshold less than 100mV
- Typical Propagation Delay Times of 2.6ns
- Typical Power Dissipation of 85mW @340 MHz
- Low Voltage TTL (LVTTTL) Level is 5V Tolerant
- Open-Circuit Fail Safe
- Output are High Impedance with $V_{CC} < 1.5V$
- Operates from a 3.3V supply
- Input common-mode voltage range 0V–3.2V
- Extended Industrial Temperature Operating Range: –40°C to 105°C
- Totally Lead-Free & Fully RoHS Compliant (Notes 1 & 2)
- Halogen and Antimony Free. “Green” Device (Note 3)
- For automotive applications requiring specific change control (i.e. parts qualified to AEC-Q100/101/104/200, PPAP capable, and manufactured in IATF 16949 certified facilities), please [contact us](https://www.diodes.com/contact-us) or your local Diodes representative. <https://www.diodes.com/quality/product-definitions/>
- Packaging (Pb-free & Green available):
 - 5-pin space-saving SOT23 (T)

Description

The DIODES™ PI90LV02A is single differential line receiver that uses low-voltage differential signaling (LVDS) to support data rates up to 680 Mbps. This device is designed for applications requiring high-speed, low-power consumption, low-noise generation, and a small package. A differential input signal (350mV) is translated by the device to a 3.3V CMOS output level. The PI90LV02A requires an external resistor.

Application(s)

Applications include point-to-point and multi-drop baseband data transmissions over impedance media of approximately 100Ω. The transmission media can be printed circuit board traces, backplanes, or cables.

The PI90LV02A and companion line drivers (The DIODES™ PI90LV01A) provide new alternatives to RS-232, PECL, and ECL devices for high-speed, point-to-point interface applications.

Block Diagram

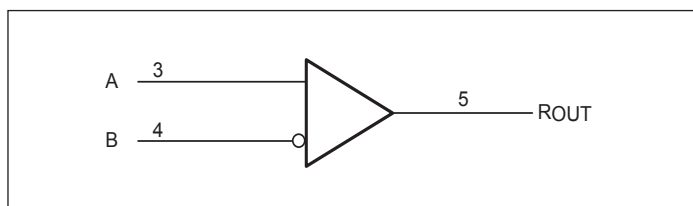

Notes:

1. No purposely added lead. Fully EU Directive 2002/95/EC (RoHS), 2011/65/EU (RoHS 2) & 2015/863/EU (RoHS 3) compliant.
2. See <https://www.diodes.com/quality/lead-free/> for more information about Diodes Incorporated’s definitions of Halogen- and Antimony-free, "Green" and Lead-free.
3. Halogen- and Antimony-free "Green" products are defined as those which contain <900ppm bromine, <900ppm chlorine (<1500ppm total Br + Cl) and <1000ppm antimony compounds.

Pin Configuration

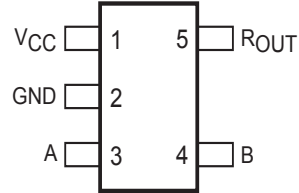

Function Table

Inputs	Outputs
$V_{ID} = V_A - V_B$	R_{OUT}
$V_{ID} > 50\text{mV}$	H
$-50\text{mV} < V_{ID} < 50\text{mV}$?
$V_{ID} \leq -50\text{mV}$	L
Open	H

Note:

H = high level

L = low level

? = indeterminate

Absolute Maximum Ratings

(unless otherwise noted)¹

Supply Voltage Range, $V_{CC}^{(2)}$	-0.5V to 4V
Voltage Range (A, B, or R_{OUT})	-0.5 to $V_{CC} + 0.5V$
ESD Rating (HBM, 1.5K Ω , 100pF)	$\geq 2KV$
Continuous Total Power Dissipation	See Dissipation Rating Table
Storage Temperature Range	-65°C to 150°C
Operating Temperature	-40°C to 105°C

Notes:

1. Stresses beyond those listed under "Absolute Maximum Ratings" may cause permanent damage to the device. These are stress ratings only, and functional operation of the device at these or any other conditions beyond those indicated under "Recommended Operating Conditions" is not implied. Exposure to Absolute-Maximum-Rated conditions for extended periods may affect device reliability.
2. All voltage values, except differential I/O bus voltages, are with respect to ground terminal.

Dissipation Rating Table

Package	$T_A = 25^\circ C$ Power Rating	Derating Factor Above $T_A = 25^\circ C^*$	$T_A = 85^\circ C$ Power Rating
5-Pin SOT-23 (T)	385mW	3.1mW/°C	200mW

*This is the inverse of the junction-to-ambient thermal resistance when board-mounted (low-K) and with no air flow.

Recommended Operating Conditions

Symbol	Parameter	Min.	Nom.	Max.	Units
V_{CC}	Supply Voltage	3.0	3.3	3.6	V
$ V_{ID} $	Magnitude of differential input voltage	0.1		0.6	
V_{IC}	Common-Mode Input Voltage (See Figure 6)	0		$2.0 - \frac{ V_{ID} }{2}$ $V_{CC} - 0.8$	
T_A	Operating free-air temperature	-40		105	°C

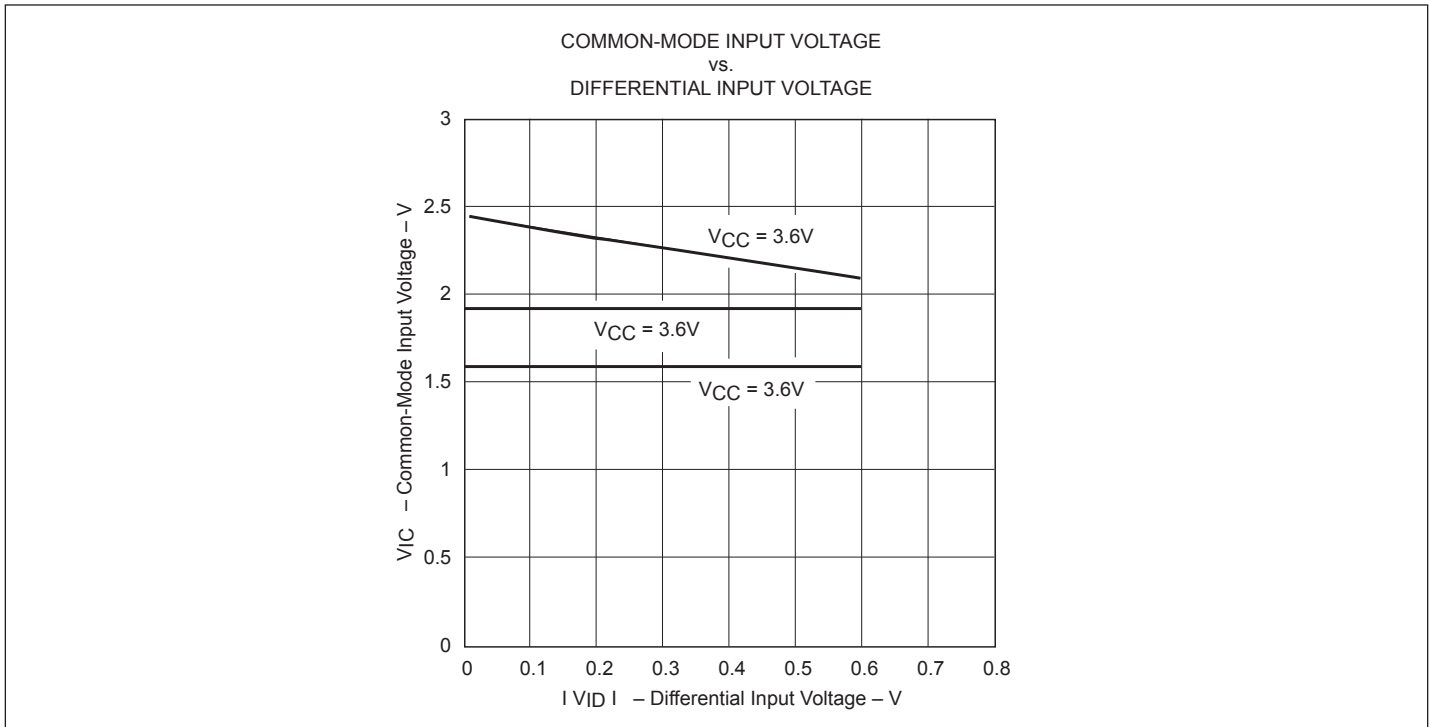

Figure 1. V_{IC} vs. V_{ID} and V_{CC}

Electrical Characteristics

$V_{CC} = 3V$ to $3.6V$ (Over Recommended Operating Conditions, unless otherwise noted).

Symbol	Parameter	Test Conditions	Min.	Typ. ⁽¹⁾	Max.	Units
V_{ITH+}	Positive-going differential input voltage threshold	See Figure 2, & Table 1			100	mV
V_{ITH-}	Negative-going differential input voltage threshold		-100			
V_{OH}	High-level output voltage	$I_{OH} = -8mA$	2.4	3		V
V_{OL}	Low-level output voltage	$I_{OL} = 8mA$		0.25	0.4	
I_{CC}	Supply current	No load, Steady state		4	7	mA
I_I	Input current (A or B inputs)	$V_I = 0V$			± 20	μA
		$V_I = 2.4V$ or $V_{CC} - 0.8$	-1.2			
I_{ID}	High-level input current ($I_{IA} - I_{IB}$)	$V_{IA} = 0V, V_{IB} = 0.1V$ $V_{IA} = 2.4V, V_{IB} = 2.3V$			± 2	
$I_{I(OFF)}$	Power-off input current (A or B inputs)	$V_{CC} = 0V, V_I = 2.4V$			20	μA

Receiver Switching Characteristics

$V_{CC} = 3V$ to $3.6V$ (Over Recommended Operating Conditions, Measured at 10Mhz only, unless noted).

Symbol	Parameter	Test Conditions	Min.	Typ. ⁽¹⁾	Max.	Units
t_{PLH}	Propagation delay time, low-to-high level output	$C_L = 5pF$, See Figure 3	1.3	2.1	3.2	ns
t_{PHL}	Propagation delay time, high-to-low level output		1.3	2.0	3.2	ns
t_r	Output signal rise time			0.7	1.4	ns
t_f	Output signal fall time			0.7	1.4	ns
$t_{sk(p)}$	Pulse skew ($ t_{PHL} - t_{PLH} $) ⁽²⁾			0.1	0.5	ns

Notes:

1. All typical values are at 25°C and with a 3.3V supply
2. $t_{sk(p)}$ is the magnitude of the time difference between the high-to-low and low-to-high propagation delay times at an output.

Parameter Measurement Information

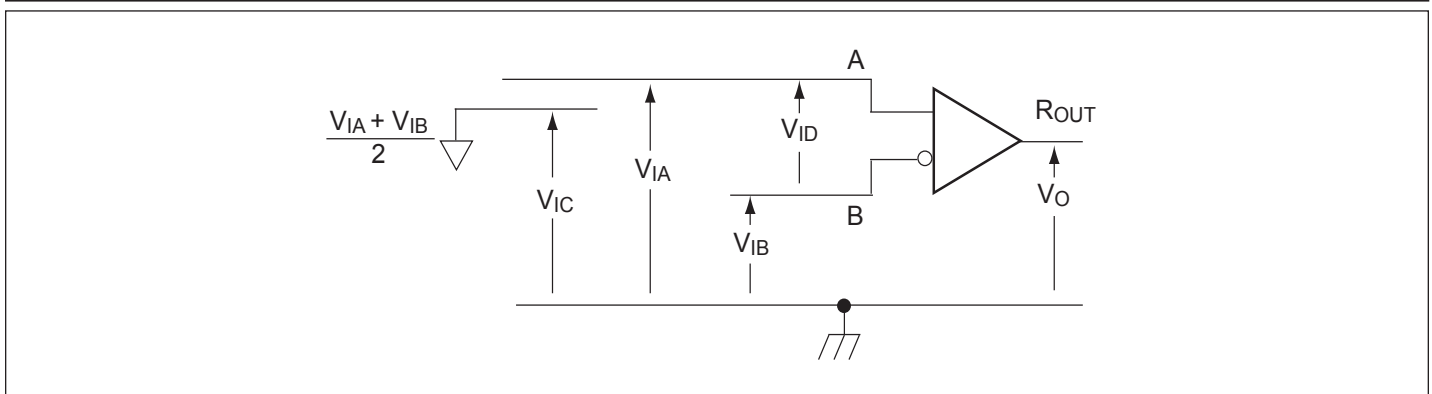
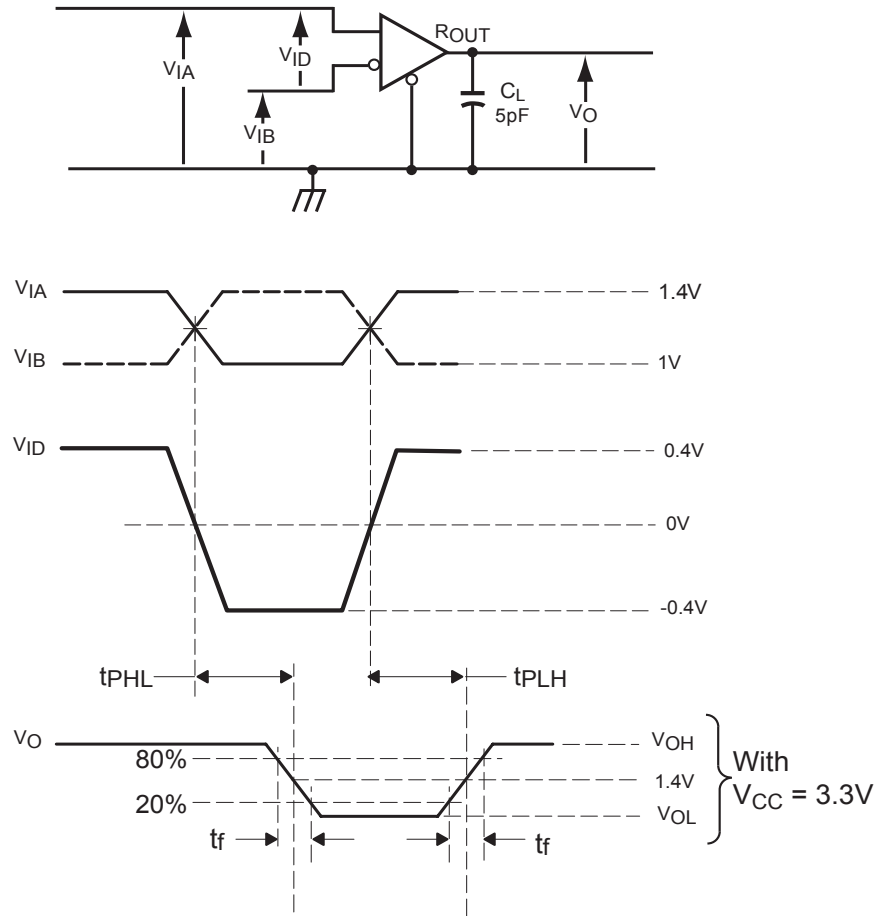

Figure 2. Receiver Voltage Definitions

PI90LV02A

Table 1. Receiver Minimum and Maximum Input Threshold Test Voltages

Applied Voltages (V)		Resulting Differential Input Voltage (mV)	Resulting Common-Mode Input Voltage (V)
V_{IA}	V_{IB}	V_{ID}	V_{IC}
1.25	1.20	50	1.225
1.15	1.20	-50	1.175
2.4	2.35	50	2.375
2.3	2.35	-50	2.325
0.05	0	50	0.025
0	0.05	-50	0.025
1.5	0.9	600	1.2
0.9	1.5	-600	1.2
2.4	1.8	600	2.1
1.8	2.4	-600	2.1
0.6	0	600	0.3
0	0.6	-600	0.3



Note A: All input pulses are supplied by a generator having the following characteristics:
 t_r or $t_f \leq 1\text{ns}$, pulse repetition rate (PRR) = 50 Mpps, pulse width = $10 \pm 0.2\text{ns}$.
 C_L includes instrumentation and fixture capacitance within 0.06m of the D.U.T.

Note B: To verify input max signalling rate, the input signal transition time (t_r/t_f) should not exceed 1.25ns.

Figure 3. Timing Test Circuit and Waveforms

PI90LV02A

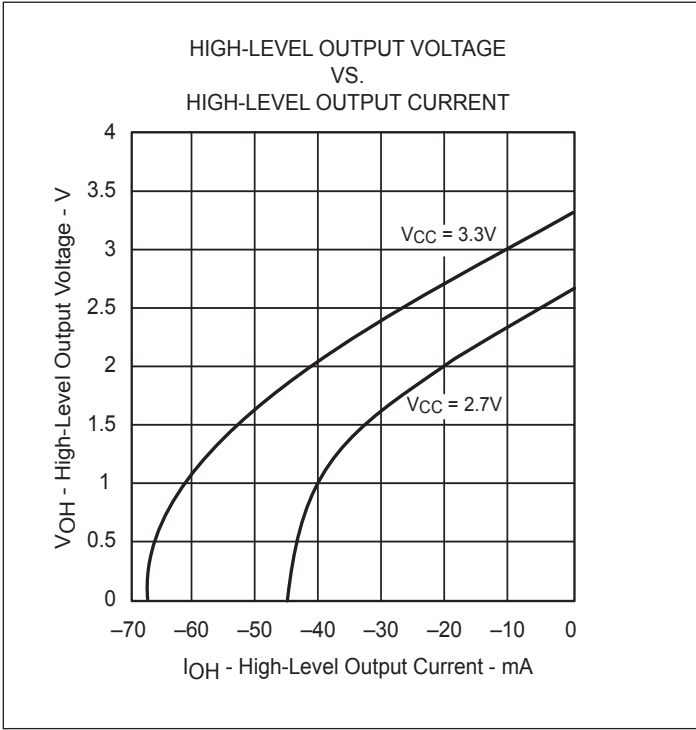

Figure 4

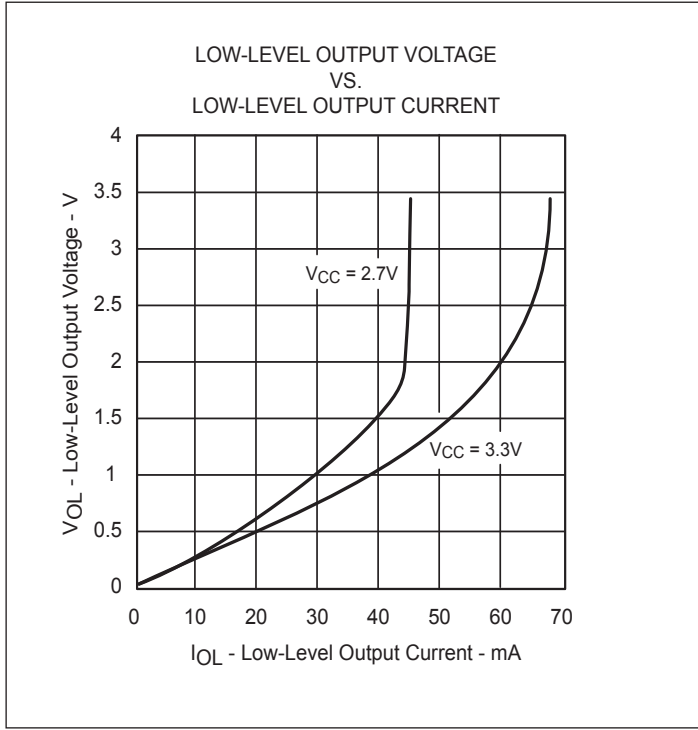

Figure 5

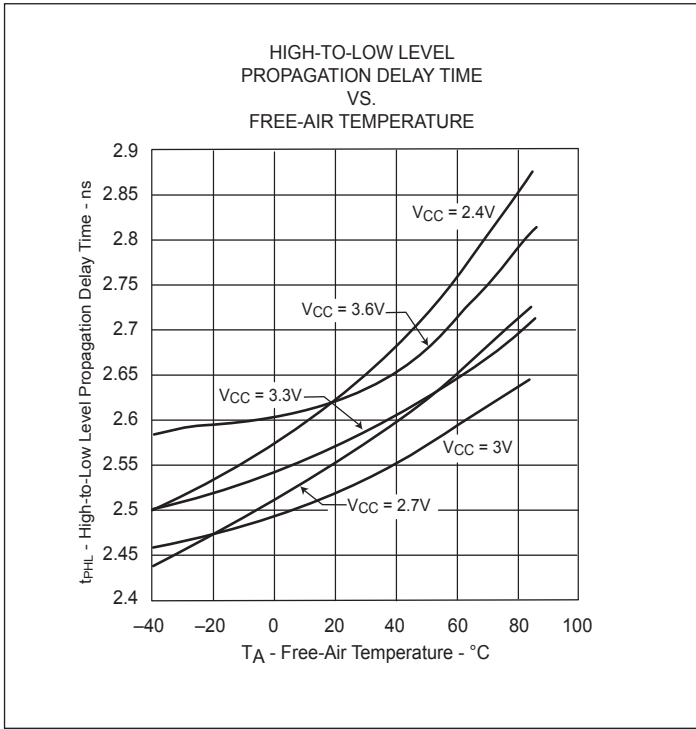

Figure 6

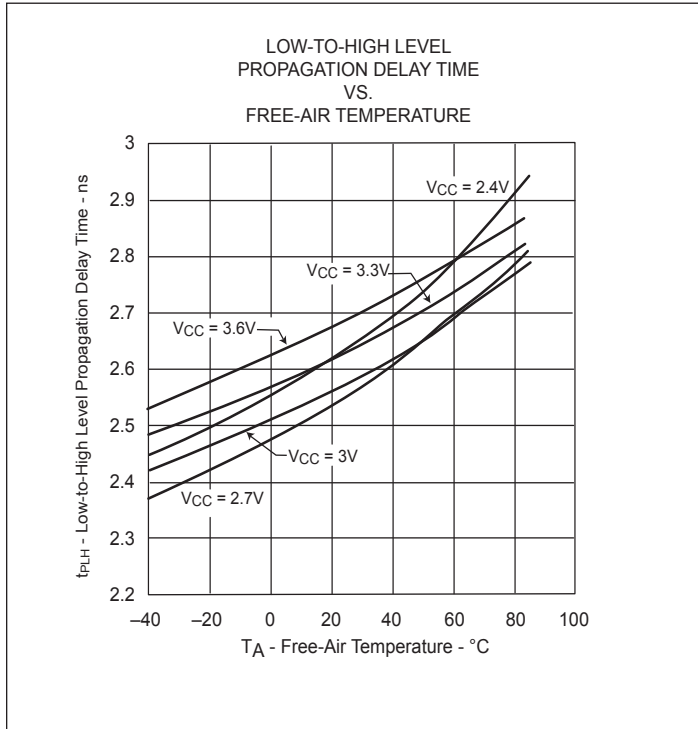

Figure 7

PI90LV02A

Part Marking



GB: PI90LV02ATE
Y: Date Code (Year)
W: Date Code (Workweek)
Line above "G" denotes Pb-free and green

Packaging Mechanical

5-SOT23 (T)

SYMBOLS	MIN.	NOM.	MAX.
A	—	—	1.45
A1	0.00	—	0.15
A2	0.90	1.15	1.30
b	0.30	—	0.50
c	0.08	—	0.22
D	2.75	2.90	3.05
E	2.60	2.80	3.00
E1	1.45	1.60	1.75
L	0.30	0.45	0.60
L1	0.60 REF		
R	0.10	—	—
R1	0.10	—	0.25
θ	0°	4°	8°
e	0.95 BSC		
e1	1.90 BSC		

NOTE :
 1. ALL DIMENSIONS IN MILLIMETERS. ANGLES IN DEGREES.
 2. DIMENSIONS EXCLUDE MOLD FLASH, PROTRUSIONS OR GATE BURRS.
 3. REFER EIAJ SC74A AND JEDEC MO-178C.

DIODES PERICOM SERIAL CONNECTIVITY		DATE: 04/14/22
DESCRIPTION: 5-Pin, Small Outline Transistor Plastic Package (SOT23)		
PACKAGE CODE: T (T5)		
DOCUMENT CONTROL #: PD-1911		REVISION: E

For latest package info.

please check: <http://www.diodes.com/design/support/packaging/pericom-packaging/packaging-mechanicals-and-thermal-characteristics/>

Ordering Information

Ordering Number	Package Code	Package Description	Top Marking
PI90LV02ATEX	T	5-pin, Small Outline Transistor Plastic Package (SOT23)	GB

Notes:

- No purposely added lead. Fully EU Directive 2002/95/EC (RoHS), 2011/65/EU (RoHS 2) & 2015/863/EU (RoHS 3) compliant.
- See <https://www.diodes.com/quality/lead-free/> for more information about Diodes Incorporated's definitions of Halogen- and Antimony-free, "Green" and Lead-free.
- Halogen- and Antimony-free "Green" products are defined as those which contain <900ppm bromine, <900ppm chlorine (<1500ppm total Br + Cl) and <1000ppm antimony compounds.
- E = Pb-free and Green
- X suffix = Tape/Reel