

PIC-32MX development board User's Manual



All boards produced by Olimex are ROHS compliant
Document revision B, April 2017

Copyright(c) 2008, OLIMEX Ltd, All rights reserved

INTRODUCTION:

The **NEW PIC-32MX** board uses the new PIC32 32 bit MIPS 4K core processor from Microchip which offers speed and performance at low cost. This board has PIC32MX340F512 microcontroller on it with its 512 KB of Flash, 32KB RAM, 80MHz clock, UARTs, PWMs, DMAs. The board has both ICSP and JTAG connectors so it can be programmed with PIC-ICD2 or JTAG tool

BOARD FEATURES:

- PIC32MX340F512 microcontroller
- UEXT connector for other Olimex modules like MOD-MP3, MOD-NRF24Lx, MOD-SMB380, MOD-RFID125 etc.
- ICSP/ICD connector for programming with PIC-ICD2 or PIC-ICD2-POCKET.
- JTAG connector
- RS232 interface with driver
- Quartz crystals 8 MHz and 32768 Hz
- Status LED
- User Button
- Reset button
- Power plug-in jack with diode bridge can be powered with AC or DC power supply
- 3.3V voltage regulator
- Extension slot on every uC pin
- Gird 100 mils
- GND bus
- Vcc bus
- Four mounting holes 3,3 mm (0,13")
- FR-4, 1.5 mm (0,062"), green soldermask, white silkscreen component print
- Dimensions (100 × 80)mm ~ (3.9 × 3.15")

ELECTROSTATIC WARNING:

The PIC-32MX board is shipped in protective anti-static packaging. The board must not be subject to high electrostatic potentials. General practice for working with static sensitive devices should be applied when working with this board.

BOARD USE REQUIREMENTS:

Cables: 1.8 meter USB A-B cable to connect PIC-KIT3, PIC-ICD2 or PIC-ICD2-POCKET to USB host on PC (if you use other programmer, you should read its specification in order to choose a cable).

Hardware: **PIC-KIT3, PIC-ICD2, PIC-ID2-POCKET**
Or any compatible tool for programming and/or debugging

!!!Warning!!! When you want to program this microcontroller with PIC-ICD2,

PIC-ICD2-POCKET or PIC-ICD2-TINY, before connecting the programmer to your target board, you should first connect the programmer to your computer and open MPLAB. There, first from menu Configure – Select Device – choose the microcontroller you are about to program, then from menu Programmer – Select Programmer – choose MPLAB ICD 2, wait while MPLAB is downloading operation system, and after ICD2 is connected – check in menu Programmer – Settings – Power – there is option – Power target circuit from MPLAB ICD 2 – this option should be forbidden, you could not select it. Now it is safe to connect the programmer to your target board.

Software: **MPLAB IDE v8.14 + MPLAB C32** for developing your own applications. The demo software shows basic functionality and how to blink LED (C source and HEX), how to read a button (C source and HEX), the use of Timer1 (C source and HEX) and UART functions (C source and HEX). The sources are compiled with MPLAB C32 C compiler.

PROCESSOR FEATURES:

- High-performance RISC CPU
 - MIPS32[®] M4K[™] 32-Bit Core with 5-Stage Pipeline
 - Single-Cycle Multiply and High-Performance Divide Unit
 - MIPS 16e[™] Mode for Up to 40% Smaller Code Size
 - User and Kernel Modes to Enable Robust Embedded System
 - Two 32-Bit Core Register Files to Reduce Interrupt Latency
 - Prefetch Cache Module to Speed Execution from Flash
- Special Microcontroller Features
 - Operating Voltage Range of 2.3V to 3.6V
 - 512K Flash and 32K Data Memory
 - Additional 12 KB of Boot Flash Memory
 - Multiple Interrupt Vectors with Individually Programmable Priority
 - Fail-Safe Clock Monitor Mode
 - Configurable Watchdog Timer with On-Chip, Low-Power RC Oscillator for Reliable Operation
- Analog Features
 - Up to 16-Channel 10-bit Analog-to-Digital Converter:
 - 500 ksp/s conversion rate
 - Conversion available during Sleep, Idle
 - Two Analog Comparators
- Peripheral Features
 - Atomic SET, CLEAR and INVERT Operation on Select Peripheral Registers
 - Up to 4-Channel Hardware DMA Controller with Automatic Data Size Detection
 - Two I²C[™] Modules
 - Two UART Modules with:
 - RS-232, RS-485 and LIN 1.2 support
 - IrDA[®] with on-chip hardware encoder and decoder
 - Parallel Master and Slave Port (PMP/PSP) with 8-bit and 16-bit Data and Up to 16 Address Lines
 - Hardware Real-Time Clock/Calendar (RTCC)
 - Five 16-bit Timers/Counters (two 16-bit pairs combine to create two 32-bit timers)
 - Five Capture Inputs
 - Five Compare PWM Outputs
 - Five External Interrupts pins
 - High-Current Sink/Source (18 mA/18 mA) on All I/O Pins
 - Configurable Open-Drain Output on Digital I/O

BLOCK DIAGRAM:

PIC32MX3XX/4XX BLOCK DIAGRAM (GENERAL PURPOSE)

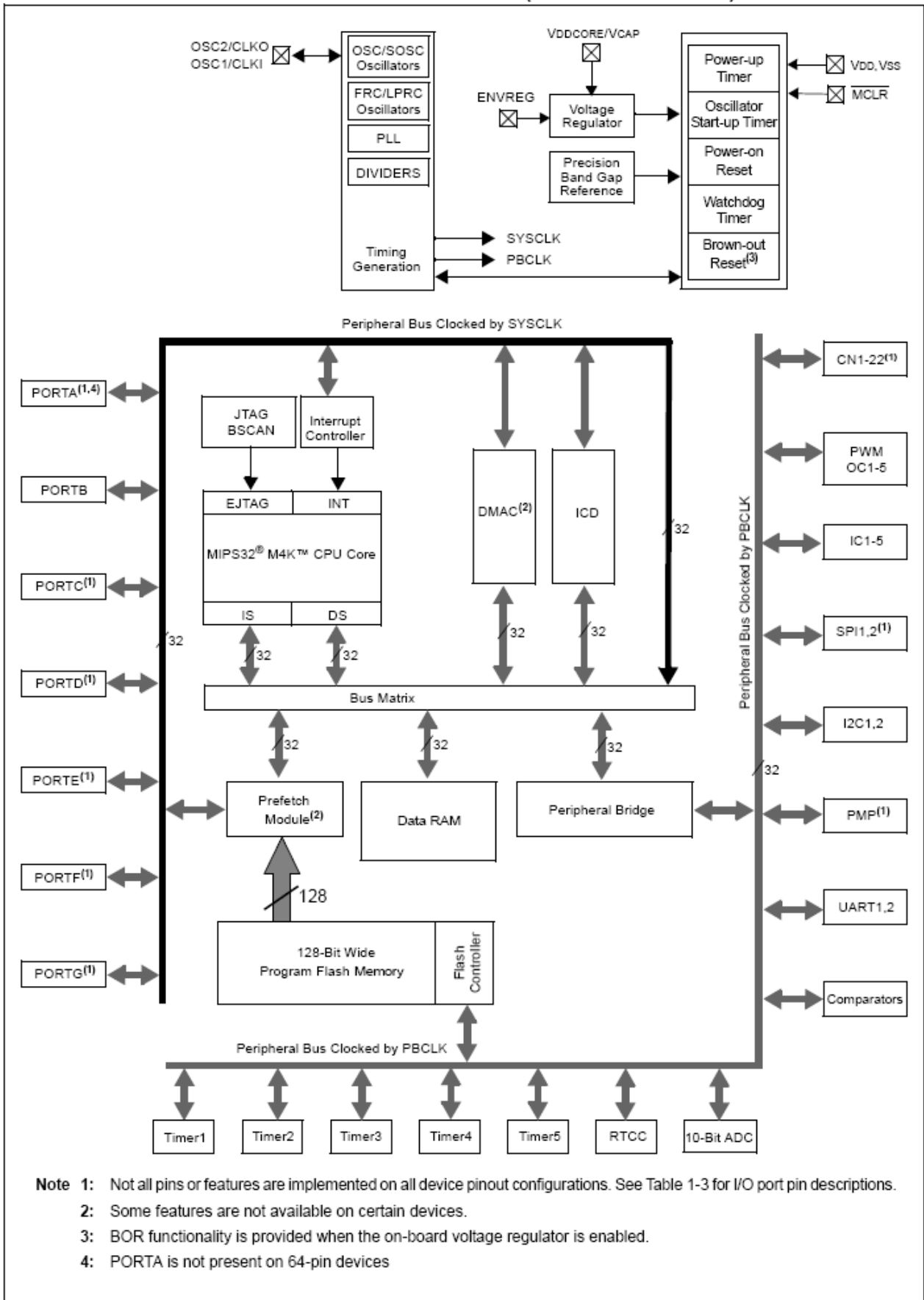

MEMORY MAP:

FLASH PARTITIONING

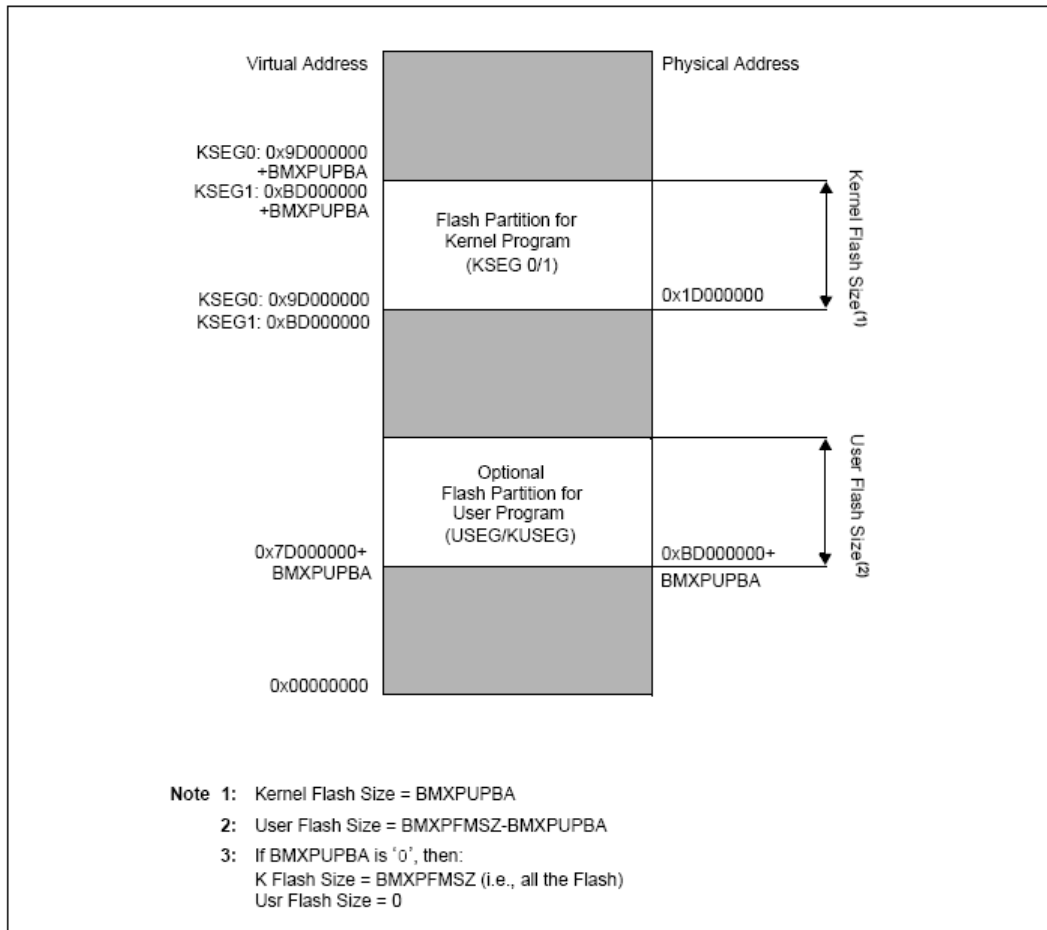

RAM PARTITIONING

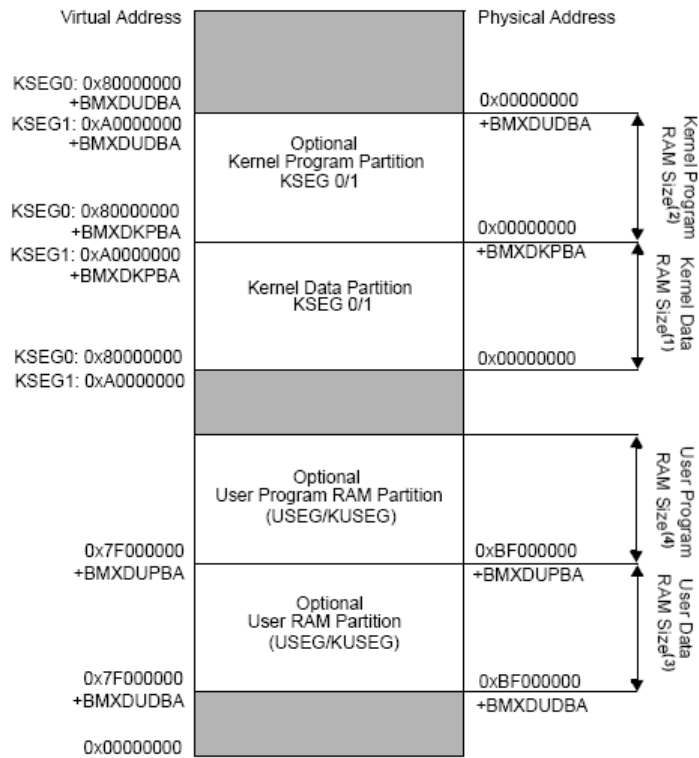

- Note 1:** Kernel Data RAM Size = BMXDKPBA
- 2:** Kernel Program RAM Size = BMXDUDBA – BMXDKPBA
- 3:** User Data RAM Size = BMXDUPBA – BMXDUDBA
- 4:** User Program RAM Size = DRM Size – BMXDUPBA
- 5:** If BMXDKPBA, BMXDUDBA or BMXDUPBA is '0', then:
 Kernel Data RAM Size = BMXDRMSZ (i.e., all RAM)
 Kernel Program RAM Size = 0
 User Data RAM Size = 0
 User Program RAM Size = 0

SCHEMATIC:

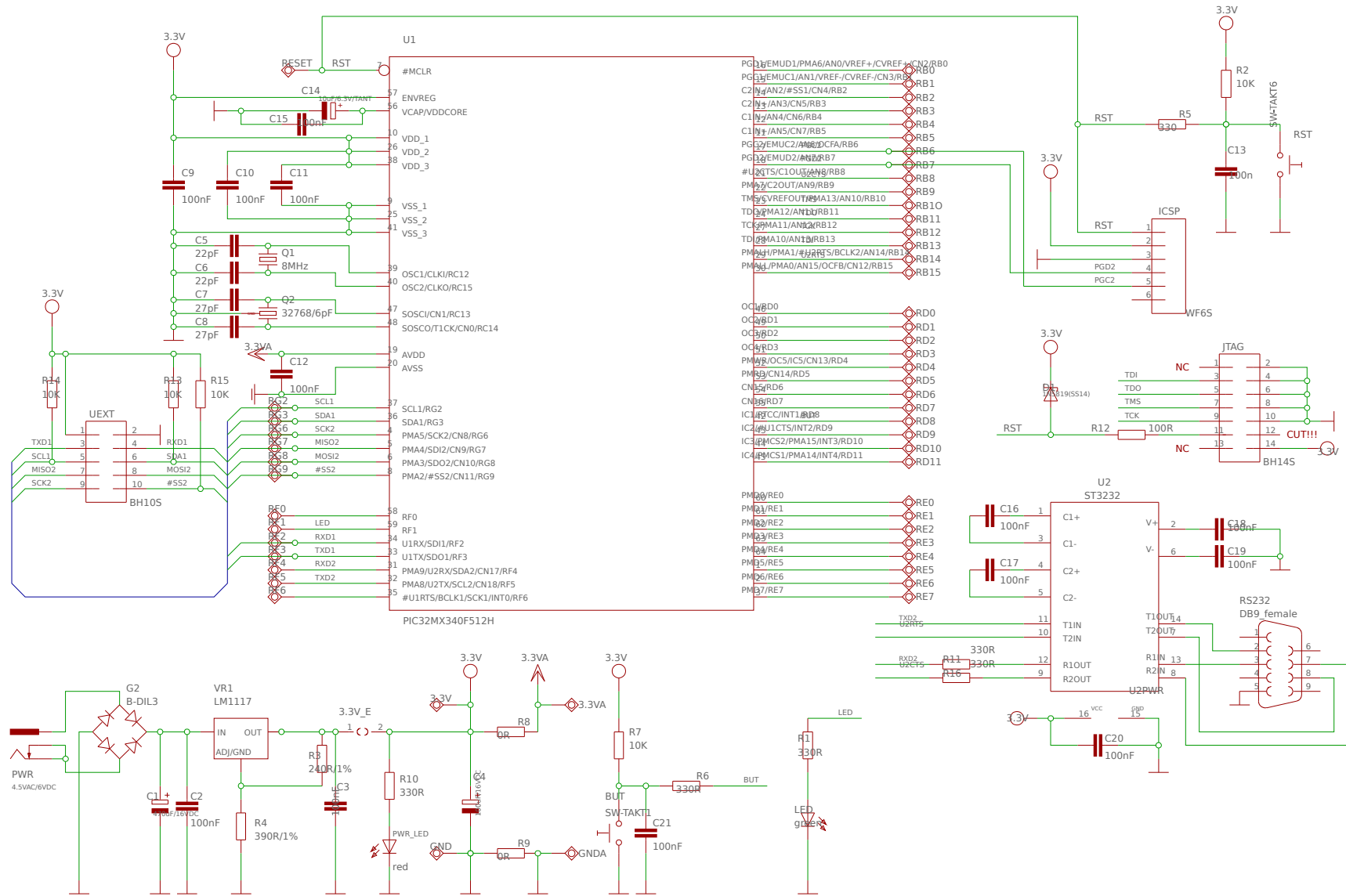

BOARD LAYOUT:

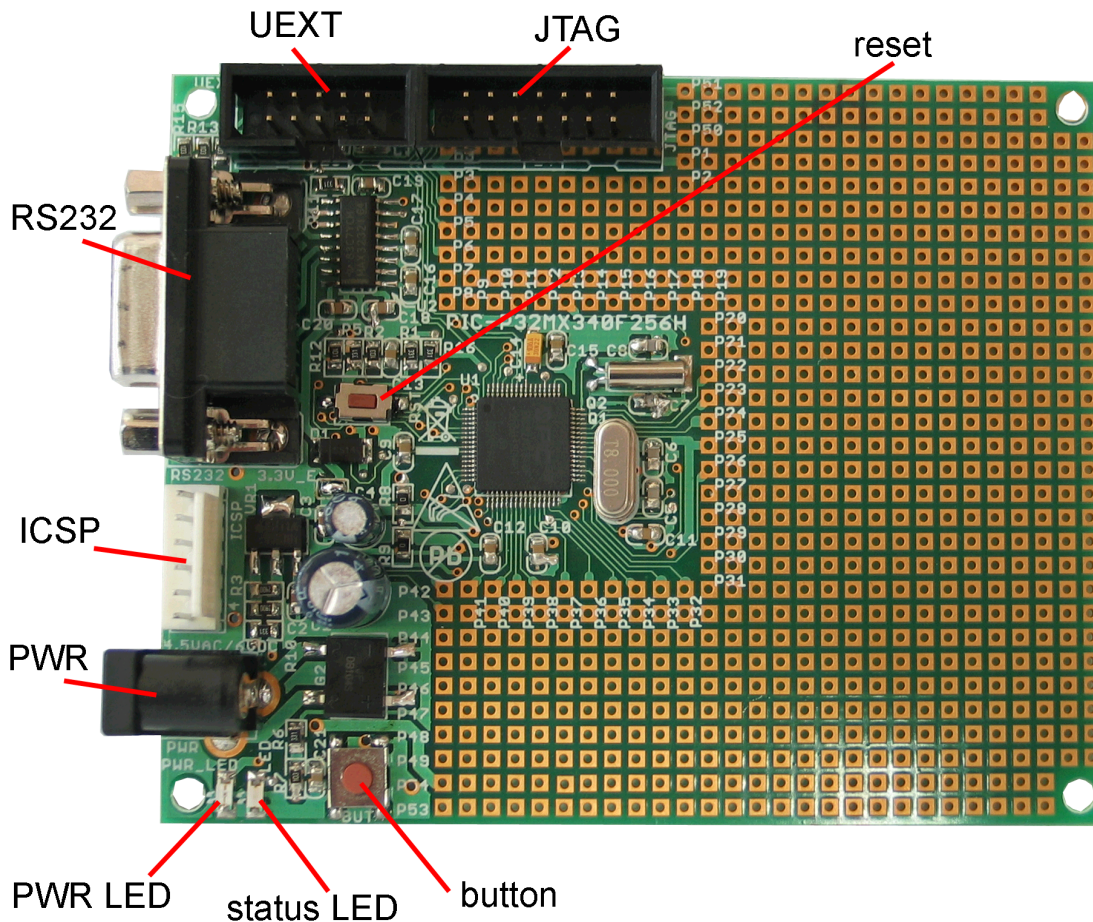

POWER SUPPLY CIRCUIT:

The typical way of powering the board is applying voltage to the power jack. PIC-32MX requires be either (4.5 – 9.0)V AC or (6.0 – 12.0)V DC applied to the power jack. The board can't be sufficiently powered by 5V DC power supply. The power consumption at 12V DC is round 70mA.

For more options of powering the board refer to the schematic.

RESET CIRCUIT:

PIC-32MX reset circuit includes a capacitor C13 (100nF) and a resistor R2 (10K Ω).

CLOCK CIRCUIT:

Quartz crystals at 8MHz and 32.768KHz are connected to PIC-32MX.

JUMPERS DESCRIPTION:

3.3V_E



Enables 3.3V supply for **PIC32MX** and all other devices.
Default state closed (shorted).

CONNECTOR DESCRIPTIONS:

JTAG:

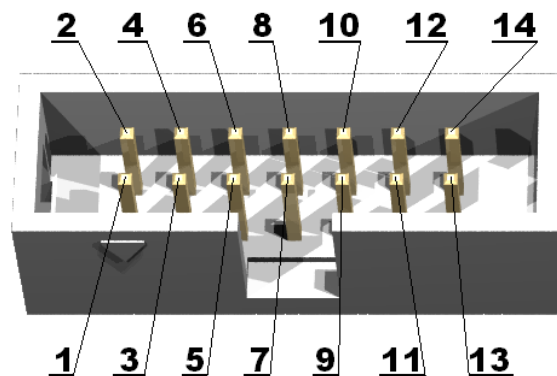

Pin #	Signal Name	Pin #	Signal Name
1	NC	2	GND
3	TDI	4	GND
5	TDO	6	GND
7	TMS	8	GND
9	TCK	10	GND
11	RST	12	(*)
13	NC	14	3.3V

(*) This pin isn't mounted.

TDI Input **Test Data In.** This is the serial data input for the shift register.
TDO Output **Test Data Out.** This is the serial data output for the shift register. Data is shifted out of the device on the negative edge of the TCK signal.
TMS Input **Test Mode Select.** The TMS pin selects the next state in the TAP state machine.
TCK Input **Test Clock.** This allows shifting of the data in, on the TMS and TDI pins. It is a positive edge triggered clock with the TMS and TCK signals that define the internal state of the device.

ISCP:

Pin #	Signal Name
1	RST
2	3.3V
3	GND
4	PGD2
5	PGC2
6	-

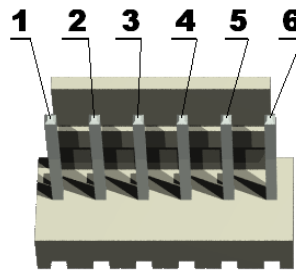

This connector allows programming and debugging via PIC-KIT3 or other compatible tool.

PWR-CON:

Pin #	Signal Name
1	VDC/VAC
2	GND

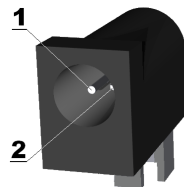

The PWR-CON connector is used to power the PIC-32MX board. You can use either AC or DC power supply. The range of each of the powering options are as follows (4.5 – 9)V for AC and (6 – 12)V for DC. Do not provide more voltage than these maximums values!

UEXT:

Pin #	Signal Name
1	3.3V OUT
2	GND
3	TXD1
4	RXD1
5	SCL1
6	SDA1
7	MISO2
8	MOSI2
9	SCK2
10	#SS2

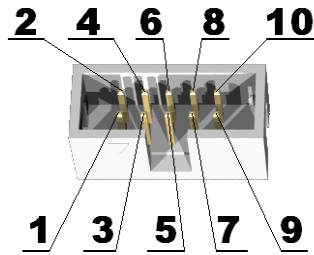

UEXT is connector for external plug-in modules.

TXD1	Output	Transmit Data 1. This is the asynchronous serial data output (RS232) for the shift register.
RXD1	Input	Receive Data 1. This is the asynchronous serial data input (RS232) for the shift register.
SCL1	I/O	Serial Clock 1. This is the synchronization clock for the I2C 1 interface. It is output from the master and input for the slave.
SDA1	I/O	Serial Data 1. Data register for the I2C interface.
MISO2	I/O	Master In Slave Out 2. When processor is master this is input SPI 2 data register. When processor is slave this is output SPI data register.
MOSI2	I/O	Maser Out Slave In 2. When processor is master this is output SPI 2 data register. When processor is slave this is input SPI data register.
SCK2	I/O	Serial Clock 2. This is the synchronization clock for the SPI 2 interface. It is ouput from the master and input for the slave.
#SS2	I/O	Slave Select 2. Save select signal dor the SPI 2. It is output from the master and input for the slave.

RS232:

Pin #	Signal Name
1	-
2	TXD2
3	RXD2
4	-
5	GND
6	-
7	U2CTS
8	U2RTS

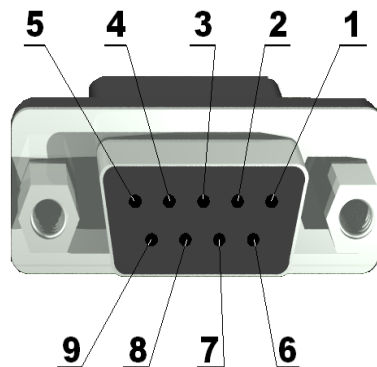

9	-
---	---

TXD2 Output **Transmit Data 2**. This is the asynchronous serial data output (RS232) for the shift register on the UART2 controller.

RXD2 Input **Receive Data 2**. This is the asynchronous serial data input (RS232) for the shift register on the UART2 controller.

U2CTS Input **UART2 Clear To Send**. The DCE device is ready to accept data.

U2RTS Output **UART2 Request To Send**. The DTE device (PIC-32MX) requests to send data.

INPUT/OUTPUT:

Button BUT – user button connected to PIC-32MX PORTD.RD8 (INT1).

RESET button – button connected to the RST pin of PIC-32MX

Power on LED (red) - its name is **PWR_LED** and indicates that power is on.

Status LED (green) - user LED connected to PIC-32MX PORTF.RF1 pin.

GETTING STARTED

In order to get started you need:

1. PIC-32MX board
2. Power supply (6-12VDC/4.5-9VAC)
3. ISP programmer
4. Cable to connect the programmer to the PC
5. Cable to connect the programmer to the board
6. Compiler/Assembler

We provide here an example configuration but you could use any compatible programmer/compiler/assembler and the corresponding cables.

Example configuration:

1. PIC-32MX board
2. 12V DC power supply adapter
3. Programmer – PIC-KIT3
4. Cable to connect the programmer to the PC – USB cable A-B
5. Cable to connect the programmer to the board – ICD2 cable (ISCP)
6. Compiler/Assembler – MPLAB v8.14 IDE + MPLAB C32

To get started you first should apply power to the board, connect the programmer to the board and to the PC, open MPLAB and write your application. After that you should compile and build your project, then you should debug it and if the previous stages are successfully finished, to program PIC-32MX. To get your application running you should disconnect the programmer from the board and reset the board.

MECHANICAL DIMENSIONS:

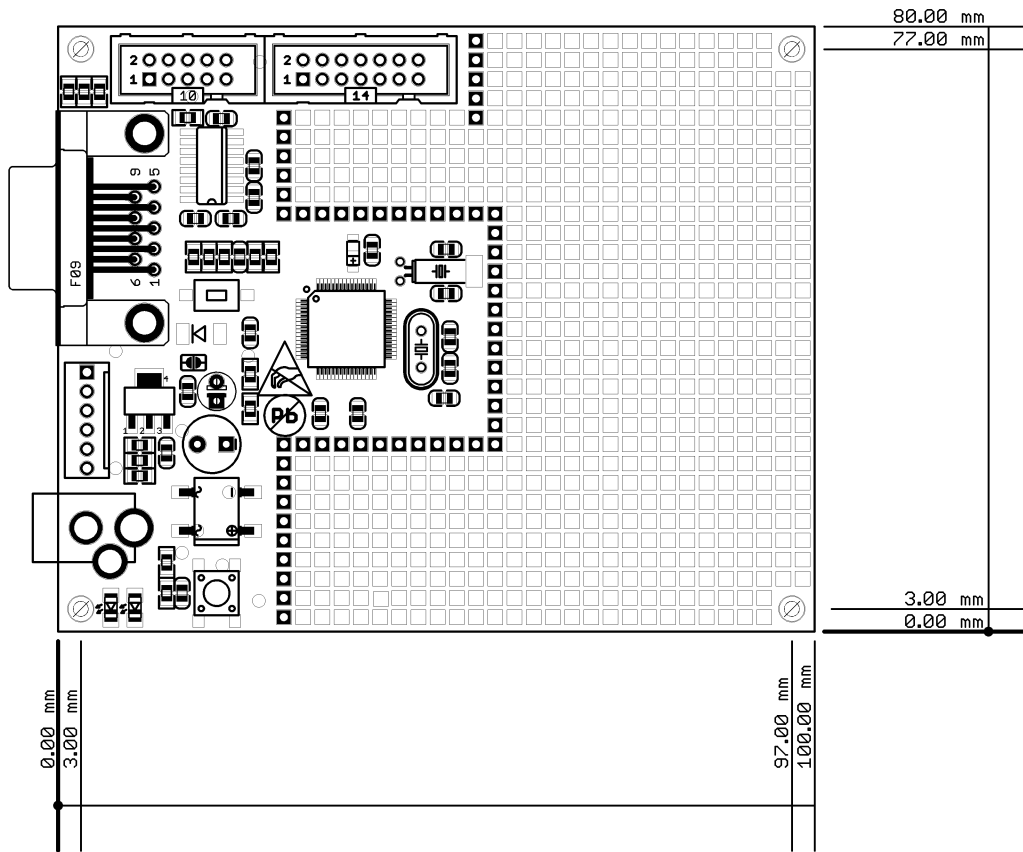

All dimensions are in mm.

AVAILABLE DEMO SOFTWARE:

All of the demo software is written under MPLAB v8.14 IDE + MPLAB C32.

1. **Blink LED demo software (C source and HEX)**
2. **Button read demo software (C source and HEX)**
3. **Timer1 demo software (C source and HEX)**
4. **UART basic demo software (C source and HEX)**
5. **UART interrupt demo software (C source and HEX)**

All of the demo software may be found on Olimex website: <https://www.olimex.com/>

ORDER CODE:

How to order?

You can order directly from our web-shop or via any of our distributors.

Check our web-site www.OLIMEX.com for more info.



All boards produced by Olimex are ROHS compliant

Document revision history:

REV.A	- created June 2008
REV.B	- updated April 2017 – extended power supply ranges