



PICO-IMX7

PICO Compute Module with NXP i.MX7 SoC

VER. 1.01

February 24, 2017

REVISION HISTORY

Revision	Date	Originator	Notes
1.00	March 28, 2016	TechNexion	Initial Public release
1.01	February 24, 2017	TechNexion	Update ordering section

TABLE OF CONTENTS

1. Introduction	7
1.1. General Introduction	7
1.2. General Care and Maintenance	8
1.3. Block Diagram	10
1.4. PICO Compute Module Compatibility.....	11
1.5. Dimensional Drawing.....	12
1.6. Component Location	13
2. Core Components	15
2.1. NXP i.MX7 ARM Cortex-A7 + Cortex-M4 Processor	15
2.2. Power Management IC (NXP PF3000)	16
2.2.1. NXP PF3000 Reset Signal	16
2.3. Memory.....	18
2.4. eMMC Storage (PICO-IMX7-EMMC only).....	19
2.5. Micro SD Cardslot (PICO-IMX7-SD only).....	20
2.6. WiFi/Bluetooth SIP Module	21
3. PICO Compute Module Connector Interfaces	25
3.1 Ethernet	25
3.2. Digital Display Sub-System (DSS) or TTL Interface	26
3.3. MIPI Display	28
3.4. MIPI Camera	29
3.5. Audio Interface	30
3.6. PCI Express.....	31
3.7. Universal Serial Bus (USB) Interface	32
3.8. SDIO/MMC Interface	33
3.9. CAN BUS Interface signals	34
3.10. Universal Asynchronous Receiver/Transmitter (UART) Interface.....	35
3.11. Serial Peripheral Interface (SPI).....	36
3.12. I ² C Bus.....	37
3.13. General Purpose Input/Output (GPIO)	38
3.14. Pulse Width Modulation (PWM)	39
3.15. Manufacturing and Boot Control.....	40
3.15.1. Boot Modes	40
3.16. Input Power Requirements.....	41
3.16.1. Power Management Signals.....	41
3.16.2. Power Sequence	42
4. PICO Compute Module Pin Assignment.....	43
5. Ordering Information	51
5.1. PICO Compute Module Product Ordering Part Numbers	51
5.1.1 Standard Part Numbers	51

5.4.2. Custom Part Number Creation Rules 51

6. Important Notice 52

7. DISCLAIMER 53

LIST OF TABLES

Table 1 - PICO Compatibility Overview	11
Table 2 - PMIC Signal Description	16
Table 3 - PMIC Reset Signal Description	16
Table 4 - PMIC Reset Signal Description	16
Table 5 - eMMC Signal Description	19
Table 6 – SD Cardslot Signal Description.....	20
Table 7 - WiFi Signal Description.....	22
Table 8 - Bluetooth Signal Description.....	23
Table 9 - Ethernet Signal Description	25
Table 10 - TTL Display Signal Description.....	27
Table 11 - MIPI Display Signal Description.....	28
Table 12 - MIPI Camera Signal Description.....	29
Table 13 - I ² S Audio Signal Description	30
Table 14 - USB Host Signal Description	31
Table 15 - USB Host Signal Description	32
Table 16 - USB OTG Signal Description.....	32
Table 17 - SDIO/MMC Interface Signal Description	33
Table 18 - CAN Bus Signal Description	34
Table 19 - UART Signal Description	35
Table 20 - SPI Channel Signal Description.....	36
Table 21 - I ² C Bus Signal Description.....	37
Table 22 - GPIO Signal Description	38
Table 23 - PWM Signal Description	39
Table 24 - Boot Selection Pins.....	40
Table 25 - Serial Downloader Boot Mode Configuration	40
Table 26 - Internal Downloader Boot Mode Configuration.....	40
Table 27 - Input Power Signals	41
Table 28 - Power Management Signals	41
Table 29 - Input Power Sequencing.....	42

LIST OF FIGURES

Figure 1 - PICO-IMX7-EMMC Block Diagram.....	10
Figure 2 - PICO-IMX7-SD Block Diagram.....	10
Figure 3 - PICO-IMX7 Compatibility Chart.....	11
Figure 4 - PICO-IMX7 Dimensional Drawing	12
Figure 5 - PICO-IMX7 Top view	13
Figure 6 - PICO-IMX7-EMMC Bottom view	13
Figure 7 - PICO-IMX7-SD Bottom view	14
Figure 8 - NXP i.MX7 Processor Blocks	15
Figure 9 - PMIC Schematics	17
Figure 10 - eMMC Schematics.....	19
Figure 11 - SD Schematics	20
Figure 12 - PICO-IMX7 Antenna u.FL Connector Location	21
Figure 13 - WiFi / BT Schematics	24
Figure 14 - Input Power sequence	42

1. Introduction

1.1. General Introduction

The PICO-IMX7 is a high performance highly integrated PICO Compute Module designed around the NXP i.MX7 Solo/Dual core ARM Cortex-A7 + Cortex-M4. The PICO-IMX7 provides an ideal building block that easily integrates with a wide range of target markets requiring compact, cost effective with low power consumption.

The modular approach offered by the PICO Compute Module gives your project scalability, fast time to market and upgradability while reducing engineering risk and maintain a competitive total cost of ownership.

1.2. General Care and Maintenance

Your device is a product of superior design and craftsmanship and should be treated with care.

The following suggestions will help you.

- Keep the device dry. Precipitation, humidity, and all types of liquids or moisture can contain minerals that will corrode electronic circuits. If your device does get wet, allow it to dry completely.
- Do not use or store the device in dusty, dirty areas. Its moving parts and electronic components can be damaged.
- Do not store the device in hot areas. High temperatures can shorten the life of electronic devices, damage batteries, and warp or melt certain plastics.
- Do not store the device in cold areas. When the device returns to its normal temperature, moisture can form inside the device and damage electronic circuit boards.
- Do not attempt to open the device.
- Do not drop, knock, or shake the device. Rough handling can break internal circuit boards and fine mechanics.
- Do not use harsh chemicals, cleaning solvents, or strong detergents to clean the device.
- Do not paint the device. Paint can clog the moving parts and prevent proper operation.
- Unauthorized modifications or attachments could damage the device and may violate regulations governing radio devices.

These suggestions apply equally to your device, battery, charger, or any enhancement. If any device is not working properly, take it to the nearest authorized service facility for service.

Regulatory information



Disposal of Waste Equipment by Users in Private Household in the European Union
This symbol on the product or on its packaging indicates that this product must not be disposed of with your other household waste. Instead, it is your responsibility to dispose of your waste equipment by handing it over to a designated collection point for the recycling of waste electrical and electronic equipment. The separate collection and recycling of your waste equipment at the time of disposal will help to conserve natural resources and ensure that it is recycled in a manner that protects human health and the environment. For more information about where you can drop off your

waste equipment for recycling, please contact your local city office, your household waste disposal service or the shop where you purchased the product.



We hereby declare that the product is in compliance with the essential requirements and other relevant provisions of European Directive 1999/5/EC (radio equipment and telecommunications terminal equipment Directive).



Federal Communications Commission (FCC) Unintentional emitter per FCC Part 15

This device has been tested and found to comply with the limits for a Class B digital device, pursuant to Part 15 of the FCC rules. These limits are designed to provide reasonable protection against harmful interference in a residential installation. This equipment generates, uses, and can radiate radio frequency energy and, if not installed and used in accordance with the instructions, may cause harmful interference to radio or television reception. However, there is no guarantee that interference will not occur in a particular installation. If this equipment does cause interference to radio and television reception, which can be determined by turning the equipment off and on, the user is encouraged to try to correct the interference by one or more of the following measures:

- Reorient or relocate the receiving antenna
- Increase the separation between the equipment and receiver
- Connect the equipment to an outlet on a different circuit from that to which the receiver is connected
- Consult the dealer or an experienced radio/TV technician for help.



WARNING! To reduce the possibility of heat-related injuries or of overheating the computer, do not place the computer directly on your lap or obstruct the computer air vents. Use the computer only on a hard, flat surface. Do not allow another hard surface, such as an adjoining optional printer, or a soft surface, such as pillows or rugs or clothing, to block airflow. Also, do not allow the AC adapter to contact the skin or a soft surface, such as pillows or rugs or clothing, during operation. The computer and the AC adapter comply with the user-accessible surface temperature limits defined by the International Standard for Safety of Information Technology Equipment (IEC 60950).

1.3. Block Diagram

Figure 1 - PICO-IMX7-EMMC Block Diagram

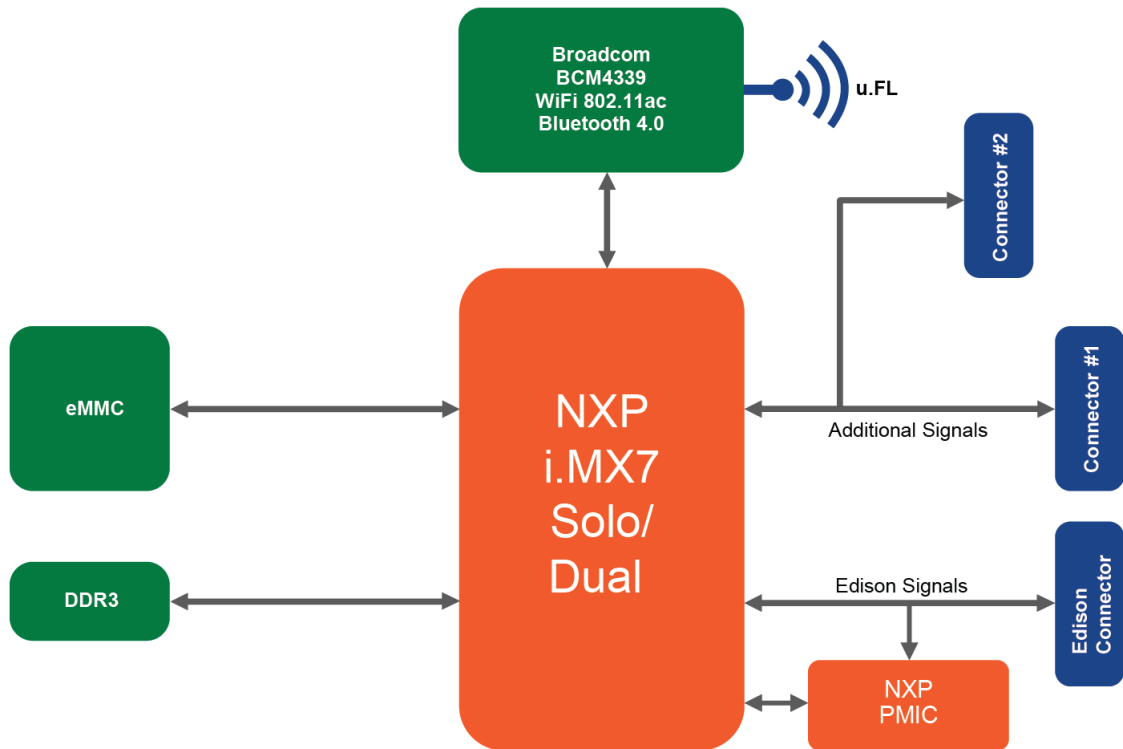
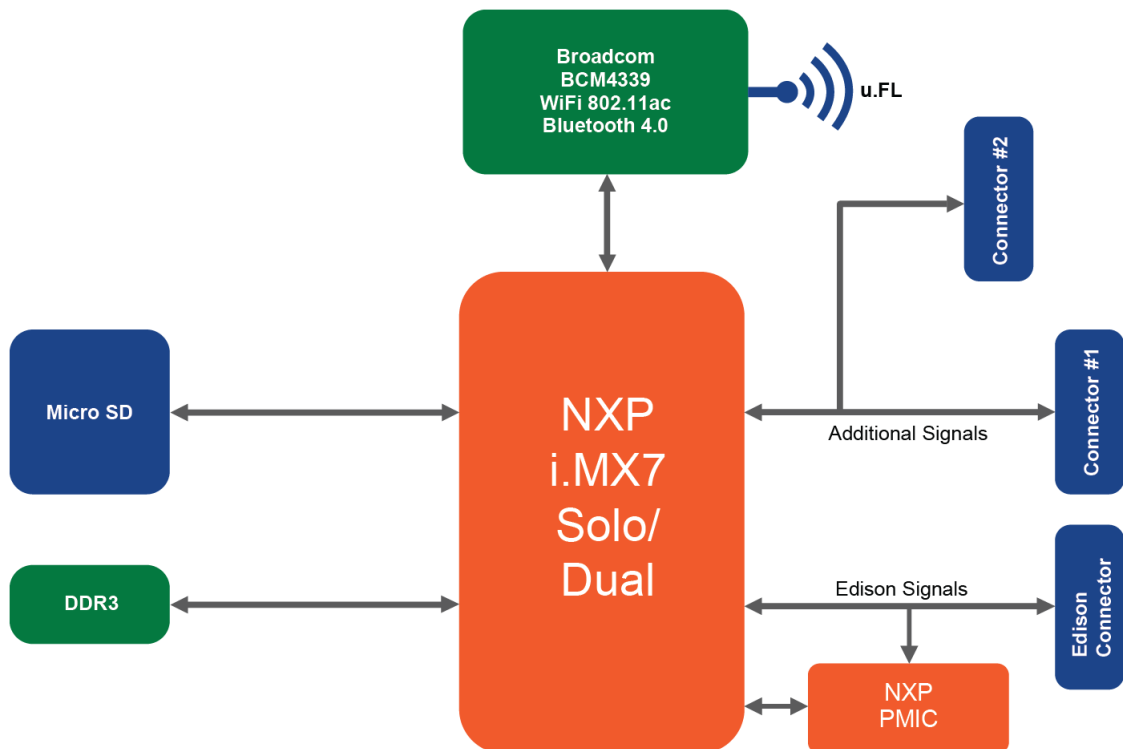

Figure 2 - PICO-IMX7-SD Block Diagram



1.4. PICO Compute Module Compatibility

The PICO-IMX7 is function compatible with Intel® Edison and adds additional multimedia I/O Interfaces on two additional expansion interfaces.

Many of the pins on PICO-IMX7 can be used for other functions.

Figure 3 - PICO-IMX7 Compatibility Chart

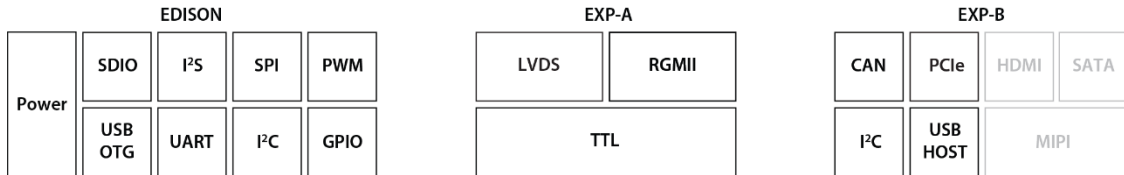

Table 1 - PICO Compatibility Overview

Interface	Description
LAN	1 Gigabit Ethernet
LVDS	Not available
HDMI	Not available
TTL Display	1 TTL 18/24 bit Display
MIPI Display	2 Lane MIPI DSI Interface
MIPI Camera	2 Lane MIPI CSI Interface
PCIe	1 Lane PCIe (i.MX7 Dual only)
SATA	Not available
USB Host	1 USB 2.0 Host port
USB OTG	1 USB 2.0 OTG port (possible to use in Host mode)
I ² S	1 I ² S interface
CAN Bus	2 FlexCAN CAN 2.0B protocol compliant interfaces
UART	1 UART (2 wire) 1 UART (4 wire)
SDIO	1 SDIO (8 bits)
SPI	1 SPI interface
I ² C	3 independent I ² C channels
GPIO	13 dedicated GPIO's available
PWM	4 PWM available

1.5. Dimensional Drawing

The PICO-IMX7 Compute Module is partly size compatible with Intel® Edison and adds several additional I/O expansion interfaces on an enlarged footprint.

2D and 3D files can be obtained from the www.technexion.com homepage.

Figure 4 - PICO-IMX7 Dimensional Drawing

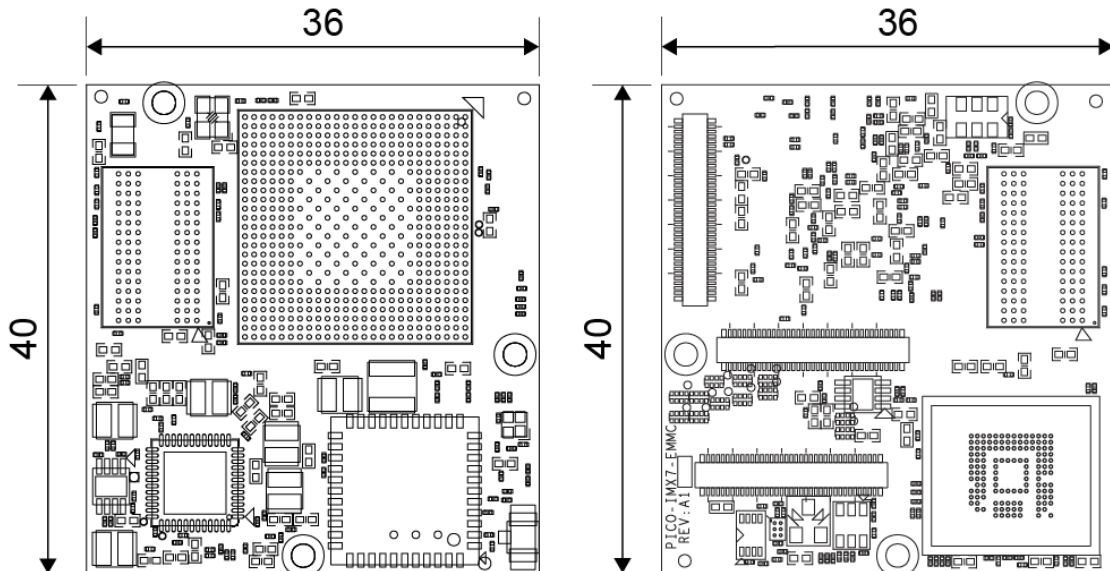

1.6. Component Location

Figure 5 - PICO-IMX7 Top view

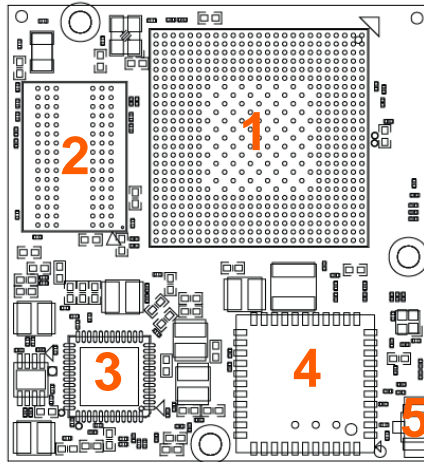

Item	Description	Item	Description
1	NXP i.MX7 Processor	2	Memory IC
3	NXP PF300 Power Management IC	4	WiFi/Bluetooth IC
5	Antenna connector		

Figure 6 - PICO-IMX7-EMMC Bottom view

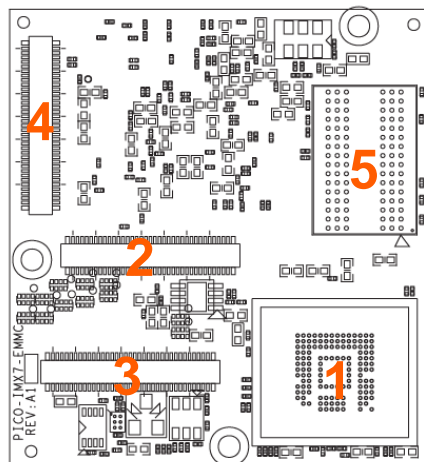

Item	Description	Item	Description
1	eMMC Storage IC	2	Intel® Edison Compatible Connector
3	Expansion Connector 1	4	Expansion Connector 2
5	Memory IC		

Figure 7 - PICO-IMX7-SD Bottom view

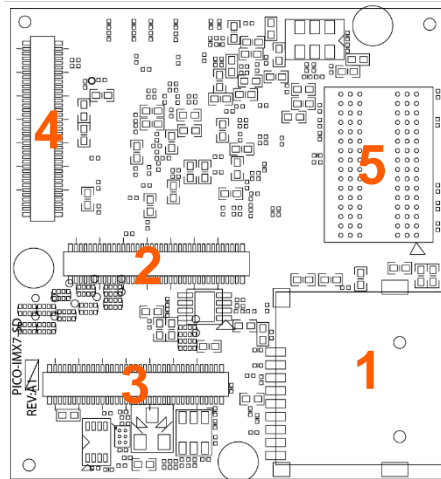

Item	Description	Item	Description
1	MicroSD cardslot	2	Intel® Edison Compatible Connector
3	Expansion Connector 1	4	Expansion Connector 2
5	Memory IC		

2. Core Components

2.1. NXP i.MX7 ARM Cortex-A7 + Cortex-M4 Processor

The i.MX7 is an ultra-efficient processor family with featuring NXP’s advanced implementation of the ARM Cortex®-A7+M4 core, which operates at speeds of up to 1 Ghz.

- The device is composed of the following major subsystems:
 - Upto Two ARM Cortex-A7 Cores (with TrustZone® technology)
 - Up to 1GHz operation frequency
 - 32 KByte L1 Instruction Cache, 32 KByte L1 Data Cache
 - Private Timer and Watchdog
 - NEON MPE coprocessor
- One ARM Cortex-M4 Core dedicated for real-time tasks, with the following features:
 - 200MHz operation frequency
 - MPU, FPU
 - 16 KByte instruction cache, 16 KByte data cache
 - 64 KByte TCM (tightly-coupled memory)
- Cryptographic acceleration and assurance module, containing cryptographic and hash engines supporting DPA (differential power analysis) protection, 32 KB secure RAM, and true and pseudo random number generator (NIST certified)
- PXP—PiXel processing pipeline for imagine resize, rotation, overlay and CSC. Offloading key pixel processing operations are required to support the display applications

Figure 8 - NXP i.MX7 Processor Blocks

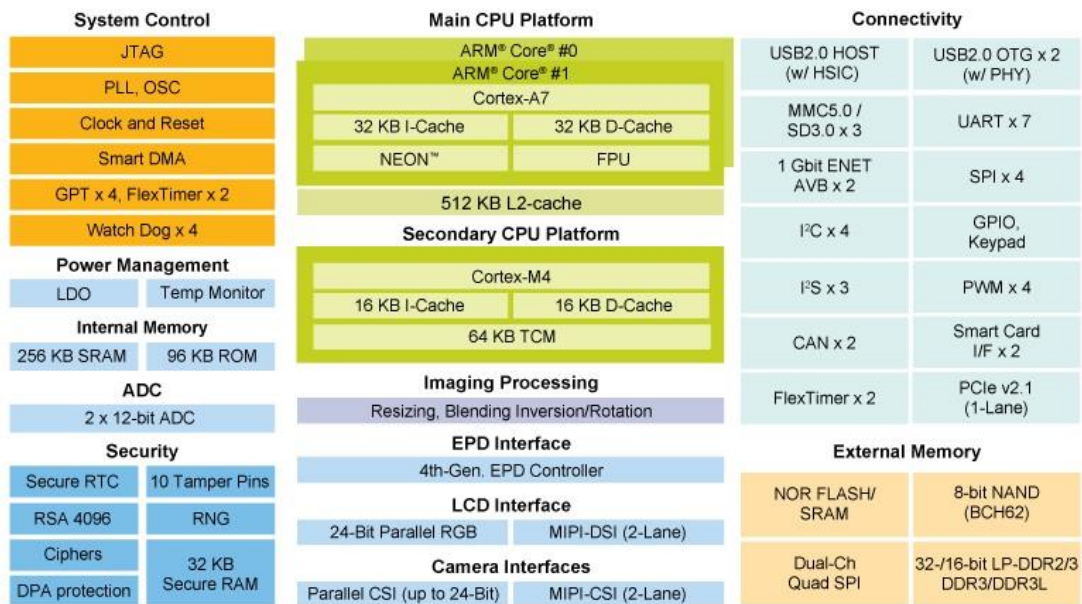

2.2. Power Management IC (NXP PF3000)

The PICO-IMX7 has on onboard NXP PF3000 power management integrated circuit (PMIC) that features a configurable architecture supporting the numerous outputs with various current ratings as well as programmable voltage and sequencing required by the components on the PICO-IMX7 module.

Table 2 - PMIC Signal Description

CPU BALL	CPU PAD NAME	Pinmux (mode)	Signal	V	I/O	Description
D12	SAI1_RXC	I2C4_SDA	SDA	3V3	I/O	I ² C bus data line
C12	SAI1_RXFS	I2C4_SCL	SCL	3V3	I/O	I ² C bus clock line
AB8	PMIC_ON_REQ	PMIC_ON_REQ	PWRON	3V3	I	PMIC Power ON/OFF Input from processor
E10	SAI1_MCLK	GPIO6_IO18	INT	3V3	I	PMIC Interrupt Signal
R6	POR_B	POR_B	RESETBMCU	3V3	I	PMIC Reset Signal
AC7	PMIC_STBY_REQ	PMIC_STBY_REQ	STANDBY	3V3	I	PMIC Standby Input Signal

2.2.1. NXP PF3000 Reset Signal

To perform a hard-reset of the PICO-IMX7 a software reset signal can be implemented.

Table 3 - PMIC Reset Signal Description

CPU BALL	CPU PAD NAME	Pinmux (mode)	Signal	V	I/O	Description
N1	GPIO1_IO00	WDOG1_WDOG	RESET	3V3	I	Connected to the PWRON signal of PMIC

To perform a hard-reset of the PICO-IMX7 an external circuit (for example a button or external watchdog IC) can be integrated on the carrier board.

Table 4 - PMIC Reset Signal Description

Connector	Signal	V	I/O	Description
E1_36	RESET	1V8	I	Connected to the PWRON signal

Figure 9 - PMIC Schematics

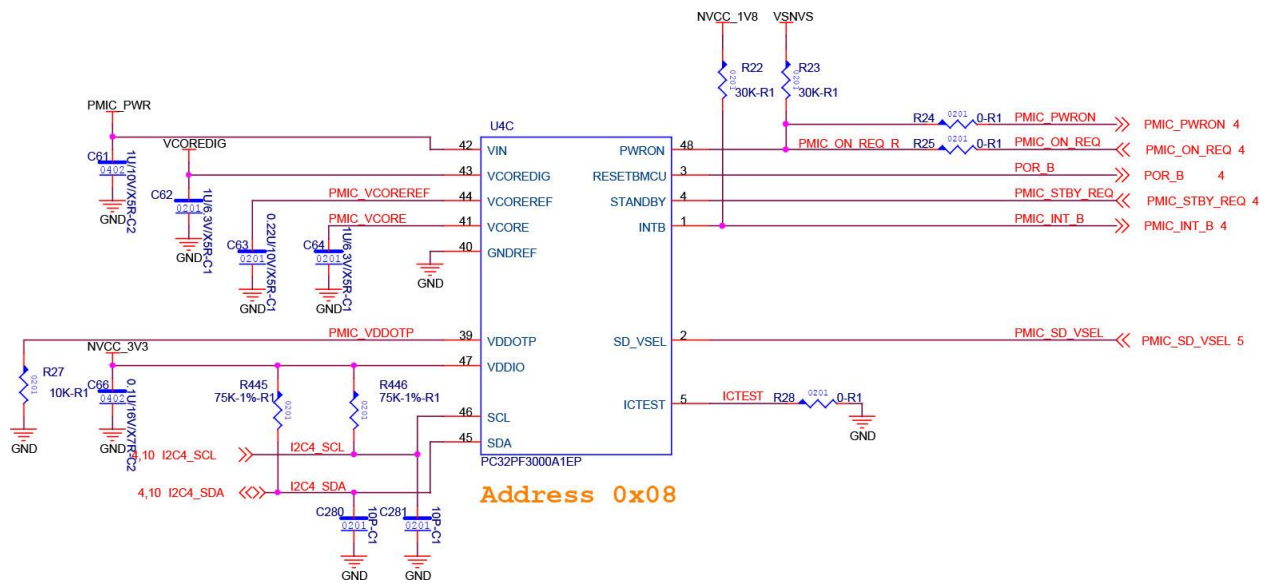

2.3. Memory

The PICO-IMX7 integrates Double Data Rate III (DDR3) Synchronous DRAM in a single (16 bit) channel configuration.

The following memory chips have been validated and tested on the PICO-IMX7 Compute Module:

- SKHynix
- Samsung
- ISSI
- Micron

For more information, please contact your TechNexion sales representative.

2.4. eMMC Storage (PICO-IMX7-EMMC only)

The PICO-IMX7 can be ordered with onboard eMMC storage in different configurations and capacity.

The onboard eMMC device is connected on the SD3 pins of the i.MX7 processor in an 8 bit width configuration.

The following eMMC chips have been validated and tested on the PICO-IMX7 System-on-Module:

- Sandisk iNAND
- Kingston eMMC
- Micron eMMC

For more information, please contact your TechNexion sales representative.

Table 5 - eMMC Signal Description

CPU BALL	CPU PAD NAME	Signal	V	I/O	Description
B2	SD3_DATA0	eMMC_DATA0	3V3	I/O	MMC/SDIO Data bit 0
A2	SD3_DATA1	eMMC_DATA1	3V3	I/O	MMC/SDIO Data bit 1
G2	SD3_DATA2	eMMC_DATA2	3V3	I/O	MMC/SDIO Data bit 2
F1	SD3_DATA3	eMMC_DATA3	3V3	I/O	MMC/SDIO Data bit 3
F2	SD3_DATA4	eMMC_DATA4	3V3	I/O	MMC/SDIO Data bit 4
E2	SD3_DATA5	eMMC_DATA5	3V3	I/O	MMC/SDIO Data bit 5
C2	SD3_DATA6	eMMC_DATA6	3V3	I/O	MMC/SDIO Data bit 6
B1	SD3_DATA7	eMMC_DATA7	3V3	I/O	MMC/SDIO Data bit 7
E1	SD3_CMD	eMMC_CMD	3V3	I/O	MMC/SDIO Command
C1	SD3_CLK	eMMC_CLK	3V3	O	MMC/SDIO Clock

Figure 10 - eMMC Schematics

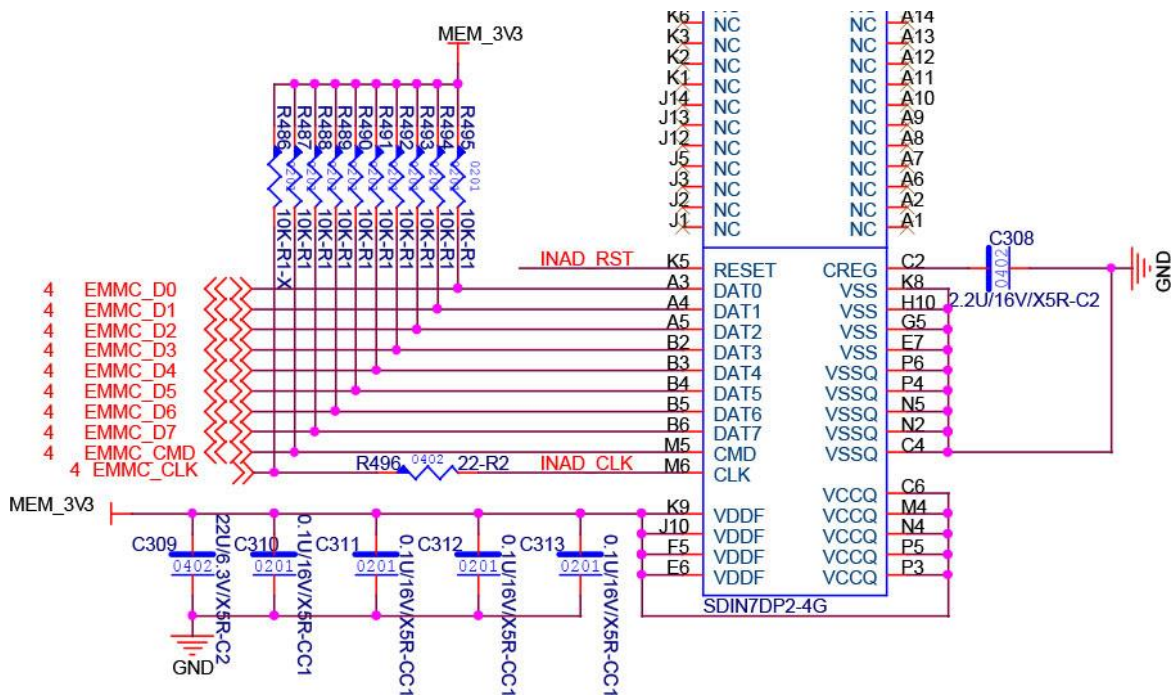

2.5. Micro SD Cardslot (PICO-IMX7-SD only)

The PICO-IMX7 can be ordered with onboard SD Cardslot.

The onboard SD Cardslot is connected on the SD3 pins of the i.MX7 processor in an 4 bit width configuration.

Table 6 – SD Cardslot Signal Description

CPU BALL	CPU PAD NAME	V	I/O	Description
B2	SD3_DATA0	3V3	I/O	MMC/SDIO Data bit 0
A2	SD3_DATA1	3V3	I/O	MMC/SDIO Data bit 1
G2	SD3_DATA2	3V3	I/O	MMC/SDIO Data bit 2
F1	SD3_DATA3	3V3	I/O	MMC/SDIO Data bit 3
E1	SD3_CMD	3V3	I/O	MMC/SDIO Command
C1	SD3_CLK	3V3	O	MMC/SDIO Clock
T5	GPIO1_IO14	3V3	I	MMC/SDIO Card Detect

Figure 11 - SD Schematics

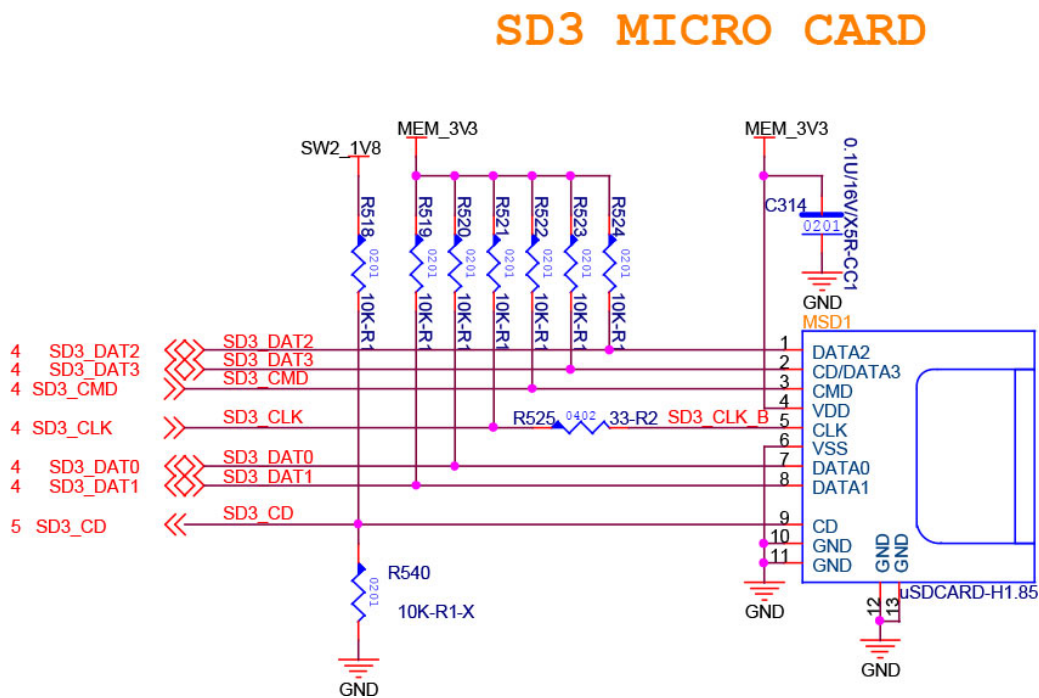

2.6. WiFi/Bluetooth SIP Module

The PICO-IMX7 can be ordered with an optional onboard WiFi/Bluetooth SIP module. The WiFi / Bluetooth SIP module is a small sized BGA mounted module.

The small size & low profile physical design make it easier for system design to enable high performance wireless connectivity without space constrain. The low power consumption and excellent radio performance make it the best solution for OEM customers who require embedded Wi-Fi + Bluetooth features.

The SIP module radio architecture & high integration MAC/BB chip provide excellent sensitivity with rich system performance.

In addition to WEP 64/128, WPA and TKIP, AES, CCX is supported to provide the latest security requirement on your network.

The SiP module is designed to operate with a single antenna for WiFi and Bluetooth to be connected to the u.FL connector available on the PICO-IMX7.

For more information, please contact your TechNexion sales representative.

Figure 12 - PICO-IMX7 Antenna u.FL Connector Location

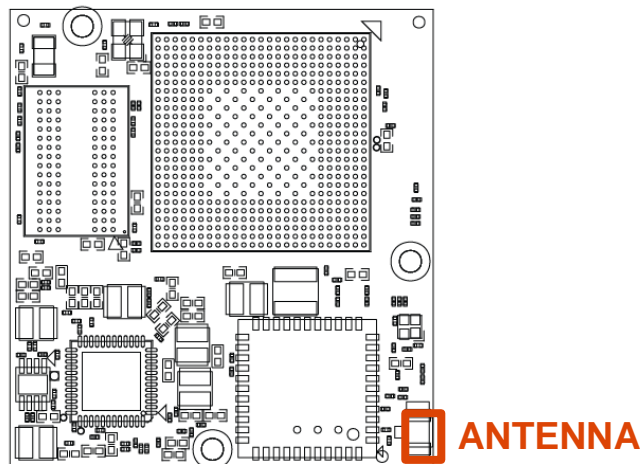

Table 7 - WiFi Signal Description

i.MX7 BALL	PAD NAME	Signal	I/O	Description
E4	SD2_DATA0	SD2_DATA_0	I/O	MMC/SDIO Data bit 0
E5	SD2_DATA1	SD2_DATA_1	I/O	MMC/SDIO Data bit 1
F5	SD2_DATA2	SD2_DATA_2	I/O	MMC/SDIO Data bit 2
E6	SD2_DATA3	SD2_DATA_3	I/O	MMC/SDIO Data bit 3
F6	SD2_CMD	SD2_CMD	I/O	MMC/SDIO Command
E3	SD2_CLK	SD2_CLK	I/O	MMC/SDIO Clock
H5	ECSPI1_SS0	GPIO4_IO19	O	Host wake up. Signal from the module to the host indicating that the module requires Attention. <ul style="list-style-type: none"> • Asserted: Host device must wake-up or remain awake. • Deserted: Host device may sleep when sleep criteria are met. The polarity of this signal is software configurable and can be asserted high or low.
H3	ECSPI1_SCLK	GPIO4_IO16	O	WiFi device wake-up: Signal from the host to the module indicating that the host requires attention. <ul style="list-style-type: none"> • Asserted: WiFi device must wake-up or remain awake. • Deserted: WiFi device may sleep when sleep criteria are met. The polarity of this signal is software configurable and can be asserted high or low.

Table 8 - Bluetooth Signal Description

i.MX7 BALL	PAD NAME	Signal	I/O	Description
G6	ECSPI2_MOSI	UART7_TXD	O	Bluetooth UART Serial Input. Serial data input for the HCI UART Interface
J5	ECSPI2_SCLK	UART7_RXD	I	Bluetooth UART Serial Output. Serial data output for the HCI UART Interface.
J6	EIM_ECSP12_SS0	UART7_CTS	I/O	Bluetooth UART Clear to Send. Active-low clear-to-send signal for the HCI UART interface.
H6	ECSPI2_MISO	UART7_RTS	I/O	Bluetooth UART Request to Send. Active-low request-to-send signal for the HCI UART interface.
E9	SAI2_RXD	AUD2_RXD	I	Integrated Interchip Sound (I ² S) channel receive data line
E8	SAI2_TXD	AUD2_TXD	O	Integrated Interchip Sound (I ² S) channel transmit data line
D8	SAI2_TXC	AUD2_TXC	O	Integrated Interchip Sound (I ² S) channel word clock signal
D9	SAI2_TXFS	AUD2_TXFS	O	Integrated Interchip Sound (I ² S) channel frame synchronization signal
H4	ECSP11_MISO	GPIO4_IO18	O	Low asserting reset for BT core
G3	SD2_RESET_B	GPIO5_IO11	I	Host UART wake up. Signal from the module to the host indicating that the module requires Attention. <ul style="list-style-type: none"> • Asserted: Host device must wake-up or remain awake. • Deserted: Host device may sleep when sleep criteria are met. The polarity of this signal is software configurable and can be asserted high or low.
G5	ECSP11_MOSI	GPIO4_IO17	O	Bluetooth device wake-up: Signal from the host to the module indicating that the host requires attention. <ul style="list-style-type: none"> • Asserted: Bluetooth device must wake-up or remain awake. • Deserted: Bluetooth device may sleep when sleep criteria are met. The polarity of this signal is software configurable and can be asserted high or low.

Figure 13 - WiFi / BT Schematics

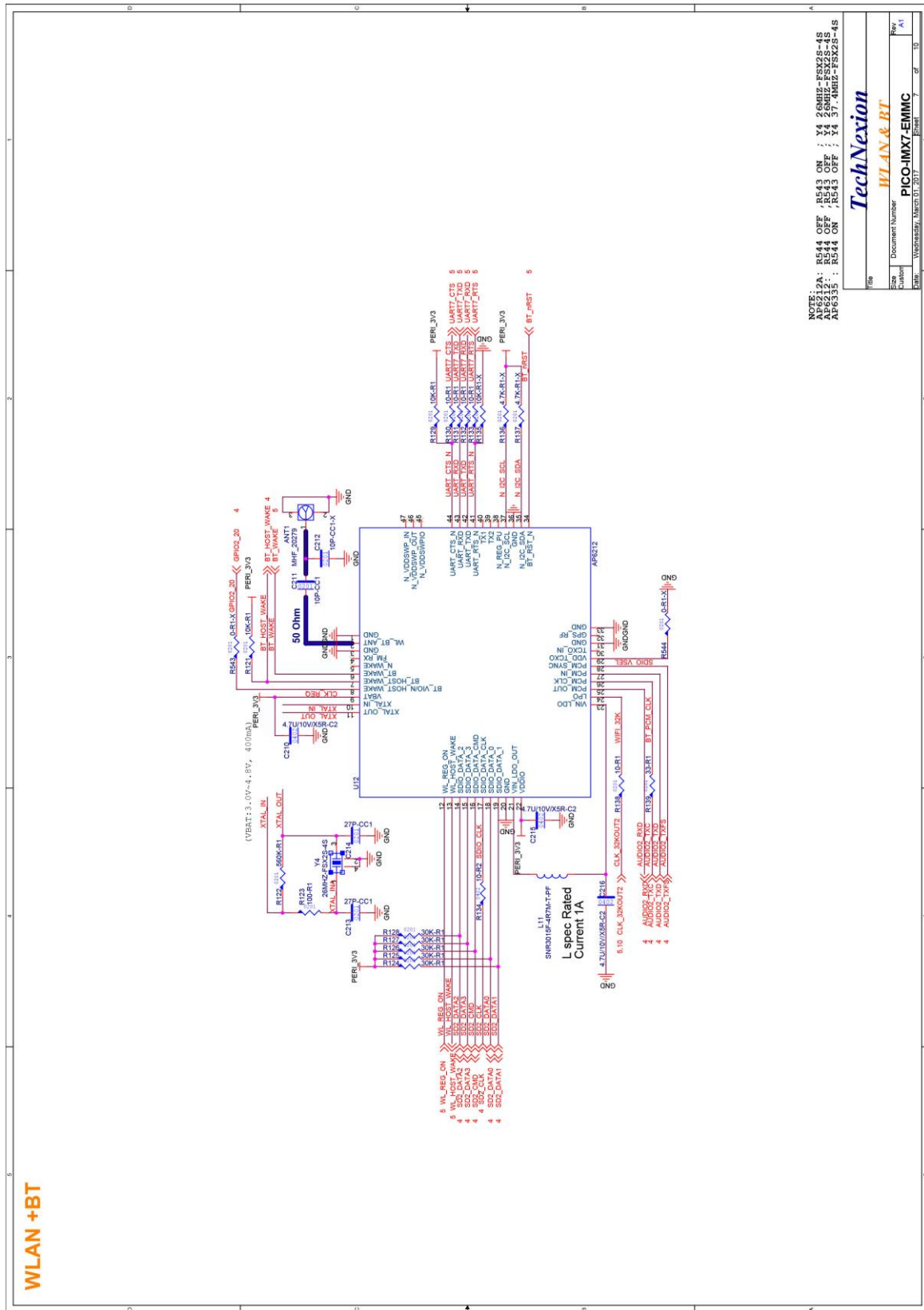

3. PICO Compute Module Connector Interfaces

3.1 Ethernet

The PICO-IMX7 implements a triple speed 10/100/1000 Mbit/s Ethernet MAC compliant with the IEEE802.3-2002 standard. The MAC layer provides compatibility with half- or full-duplex 10/100 Mbit/s Ethernet LANs and full-duplex gigabit Ethernet LANs.

The Ethernet MAC supports the following features:

- Implements the full 802.3 specification with preamble/SFD generation, frame padding generation, CRC generation and checking
- Supports zero-length preamble
- Dynamically configurable to support 10/100 Mbit/s and gigabit operation
- Supports 10/100 Mbit/s full-duplex and configurable half-duplex operation
- Supports gigabit full-duplex operation
- Compliant with the AMD magic packet detection with interrupt for node remote power management
- Seamless interface to commercial ethernet PHY devices via one of the following:
 - 4-bit Media Independent Interface (MII) operating at 2.5/25 MHz.
 - 4-bit non-standard MII-Lite (MII without the CRS and COL signals) operating at 2.5/25 MHz.
 - 2-bit Reduced MII (RMII) operating at 50 MHz.
 - (Double data rate) 4-bit Reduced GMII (RGMII) operating at 125 MHz.

For additional details, please refer to the “Ethernet MAC (ENET)” chapter of the “i.MX7 Reference Manual”.

Table 9 - Ethernet Signal Description

PIN	CPU BALL	CPU PAD NAME	Signal	V	I/O	Description
X1_33	C3	SD2_WP	ENET1_MDC	3V3		Management data clock reference
X1_35	D3	SD2_CD_B	ENET1_MDIO	3V3		Management data
X1_37	G1	SD3_RESET_B	GPIO6_IO11	3V3		Ethernet reset
X1_39	J1	SD3_STROBE	GPIO6_IO10	3V3		Ethernet interrupt output
X1_41	N2	GPIO1_IO01	CCM_ENET_REF_CLK3	3V3		Synchronous Ethernet recovered clock
X1_43	E16	ENET1_TX_CTL	RGMII1_TX_CTL	1V8	O	RGMII transmit enable
X1_45	E15	ENET1_RX_CTL	RGMII1_RX_CTL	1V8	I	RGMII receive data valid
X1_49	F16	ENET1_TXC	RGMII1_TXC	1V8	O	RGMII transmit clock
X1_51	F17	ENET1_TDATA0	RGMII1_TD0	1V8	O	RGMII transmit data 0
X1_53	E17	ENET1_TDATA1	RGMII1_TD1	1V8	O	RGMII transmit data 1
X1_55	E18	ENET1_TDATA2	RGMII1_TD2	1V8	O	RGMII transmit data 2
X1_57	D18	ENET1_TDATA3	RGMII1_TD3	1V8	O	RGMII transmit data 3
X1_61	F15	ENET1_RXC	RGMII1_RXC	1V8	I	RGMII receive clock
X1_63	E14	ENET1_RDATA0	RGMII1_RD0	1V8	I	RGMII receive data 0
X1_65	F14	ENET1_RDATA1	RGMII1_RD1	1V8	I	RGMII receive data 1
X1_67	D13	ENET1_RDATA2	RGMII1_RD2	1V8	I	RGMII receive data 2
X1_69	E13	ENET1_RDATA3	RGMII1_RD3	1V8	I	RGMII receive data 3

3.2. Digital Display Sub-System (DSS) or TTL Interface

The Parallel Display interface of PICO-IMX7 is derived from the eLCDIF subsystem. The eLCDIF is a general purpose display controller used to drive a wide range of display devices varying in size and capability. The eLCDIF is designed to support dumb (synchronous 24-bit Parallel RGB interface) and smart (asynchronous parallel MPU interface) LCD devices.

The block has several major features:

- Bus master interface to source frame buffer data for display refresh. This interface can also be used to drive data for "Smart" displays.
- PIO interface to manage data transfers between "Smart" displays and SoC.
- 8/16/18/24/32 bit LCD data bus support available depending on I/O mux options.
- Programmable timing and parameters for MPU, VSYNC and DOTCLK LCD interfaces to support a wide variety of displays.
- ITU-R BT.656 mode (called Digital Video Interface or DVI mode here) including progressive-to-interlace feature and RGB to YCbCr 4:2:2 color space conversion to support 525/60 and 625/50 operation.

For additional details, please refer to the "Enhanced LCD Interface" chapter and the "Pixel Pipeline (PXP)" chapter of the "i.MX7 Application Processor Reference Manual".

Table 10 - TTL Display Signal Description

PIN	CPU BALL	CPU PAD NAME	Signal	V	I/O	Description
X1_8	G23	LCD1_DATA23	LCD_DATA23	3V3	O	LCD Pixel Data bit 23
X1_10	D25	LCD1_DATA22	LCD_DATA22	3V3	O	LCD Pixel Data bit 22
X1_12	E24	LCD1_DATA21	LCD_DATA21	3V3	O	LCD Pixel Data bit 21
X1_14	C25	LCD1_DATA20	LCD_DATA20	3V3	O	LCD Pixel Data bit 20
X1_16	D24	LCD1_DATA19	LCD_DATA19	3V3	O	LCD Pixel Data bit 19
X1_18	E23	LCD1_DATA18	LCD_DATA18	3V3	O	LCD Pixel Data bit 18
X1_20	G21	LCD1_DATA17	LCD_DATA17	3V3	O	LCD Pixel Data bit 17
X1_22	B25	LCD1_DATA16	LCD_DATA16	3V3	O	LCD Pixel Data bit 16
X1_24	C24	LCD1_DATA15	LCD_DATA15	3V3	O	LCD Pixel Data bit 15
X1_26	D23	LCD1_DATA14	LCD_DATA14	3V3	O	LCD Pixel Data bit 14
X1_28	E22	LCD1_DATA13	LCD_DATA13	3V3	O	LCD Pixel Data bit 13
X1_30	F21	LCD1_DATA12	LCD_DATA12	3V3	O	LCD Pixel Data bit 12
X1_32	G20	LCD1_DATA11	LCD_DATA11	3V3	O	LCD Pixel Data bit 11
X1_34	B24	LCD1_DATA10	LCD_DATA10	3V3	O	LCD Pixel Data bit 10
X1_36	C23	LCD1_DATA09	LCD_DATA09	3V3	O	LCD Pixel Data bit 9
X1_38	E21	LCD1_DATA08	LCD_DATA08	3V3	O	LCD Pixel Data bit 8
X1_40	F20	LCD1_DATA07	LCD_DATA07	3V3	O	LCD Pixel Data bit 7
X1_42	A24	LCD1_DATA06	LCD_DATA06	3V3	O	LCD Pixel Data bit 6
X1_44	B23	LCD1_DATA05	LCD_DATA05	3V3	O	LCD Pixel Data bit 5
X1_46	C22	LCD1_DATA04	LCD_DATA04	3V3	O	LCD Pixel Data bit 4
X1_48	A23	LCD1_DATA03	LCD_DATA03	3V3	O	LCD Pixel Data bit 3
X1_50	B22	LCD1_DATA02	LCD_DATA02	3V3	O	LCD Pixel Data bit 2
X1_52	A22	LCD1_DATA01	LCD_DATA01	3V3	O	LCD Pixel Data bit 1
X1_54	D21	LCD1_DATA00	LCD_DATA00	3V3	O	LCD Pixel Data bit 0
X1_56	C21	LCD1_RESET	LCD_RS	3V3	O	LCD backlight enable/disable
X1_58	E25	LCD1_HSYNC	LCD_HSYNC	3V3	O	LCD Horizontal Synchronization
X1_60	F25	LCD1_ENABLE	LCD_ENABLE	3V3	O	LCD dot enable pin signal
X1_62	F24	LCD1_VSYNC	LCD_VSYNC	3V3	O	LCD Vertical Synchronization
X1_64	E20	LCD1_CLK	LCD_CLK	3V3	O	LCD Pixel Clock
X1_66	T1	GPIO1_IO11	PWM4_OUT	3V3	O	LCD Backlight brightness Control
X1_68	P2	GPIO1_IO06	GPIO1_IO06	3V3	O	LCD Voltage On

3.3. MIPI Display

The PICO-IMX7 provides MIPI Serial Interface camera signals.

The MIPI DSI Host Controller supports the following features:

Complies to MIPI DSI Standard Specification V1.01r11

- Maximum resolution ranges up to SXGA+(1400 x 11050 @ 60 Hz, 24 bpp)
 - It should be decided on bandwidth between input clock (video clock) and output clock (D-PHY HS clock).
- Supports 1, 2 data lanes
- Supports pixel format: 16 bpp, 18 bpp packed, 18 bpp loosely packed (3 byte format), and 24bpp

Interfaces

- Complies with Protocol-to-PHY Interface (PPI) in 1.0 Gbps / 1.5 Gbps MIPI DPHY
- Supports RGB Interface for Video Image Input from general display controller
- Supports S-i80 (Synchronous i80) Interface for Command Mode Image input from display controller
- Supports PMS control interface for PLL to configure byte clock frequency
- Supports Prescaler to generate escape clock from byte clock

For additional details, please refer to the “MIPI DSI Host Controller” chapter of the “i.MX7 Reference Manual”.

Table 11 - MIPI Display Signal Description

PIN	CPU BALL	CPU PAD NAME	V	I/O	Description
X2_53	B20	MIPI_DSI_D0_P	2V5	O	MIPI Display Serial Interface data pair 0 positive signal
X2_55	A20	MIPI_DSI_D0_N	2V5	O	MIPI Display Serial Interface data pair 0 negative signal
X2_57	B18	MIPI_DSI_D1_P	2V5	O	MIPI Display Serial Interface data pair 1 positive signal
X2_59	A18	MIPI_DSI_D1_N	2V5	O	MIPI Display Serial Interface data pair 1 negative signal
X2_61	A19	MIPI_DSI_CLK_N	2V5	O	MIPI Display Serial Interface clock pair negative signal
X2_63	B19	MIPI_DSI_CLK_P	2V5	O	MIPI Display Serial Interface clock pair positive signal

3.4. MIPI Camera

The PICO-IMX7 provides MIPI Serial Interface camera signals.

The MIPI CSI-2 Host Controller supports the following features:

- Compliant to MIPI D-phy standard specification V1.1
- Compliant to previous version of Samsung D-phy
- Compliant to MIPI CSI2 Standard Specification V1.01r06
- Support primary and secondary Image format
- YUV420, YUV420 (Legacy), YUV420 (CSPS), YUV422 of 8-bits and 10-bits
- RGB565, RGB666, RGB888
- RAW6, RAW7, RAW8, RAW10, RAW12, RAW14
- Compressed format: 10-6-10, 10-7-10, 10-8-10, 14-10-14
- All of user defined byte-based Data packet
- Support embedded byte-based non-Image data packet and generic short packets
- Support interleave mode using Virtual channel
- Support up to two D-PHY Rx Data Lanes

Interfaces

- Compatible to PPI (Protocol-to-PHY Interface) in MIPI D-PHY Specification
- Image output data bus width: 32 bits (optional)
- Support four channel virtual channels or data interleave

Memory

- Non-image memory
- 8 KB SRAM for asynchronous clock domain
- This memory can store maximum 4 KB of non-image data per frame.

Image Memory

- 1KB SRAM for image memory
- This memory works as buffering for the difference of input / output bandwidth
- Pixel clock can be gated when no ppi data is coming.

For additional details, please refer to the “MIPI - Camera Serial Interface Host Controller (MIPI_CSI)” chapter of the “i.MX7 Reference Manual”.

Table 12 - MIPI Camera Signal Description

PIN	CPU BALL	CPU PAD NAME	V	I/O	Description
X2_31	A15	MIPI_CSI_CLK_N	2V5	I	MIPI Camera Serial Interface clock pair negative signal
X2_33	B15	MIPI_CSI_CLK_P	2V5	I	MIPI Camera Serial Interface clock pair positive signal
X2_35	A16	MIPI_CSI_D0_N	2V5	I	MIPI Camera Serial Interface data pair 0 negative signal
X2_37	B16	MIPI_CSI_D0_P	2V5	I	MIPI Camera Serial Interface data pair 0 positive signal
X2_39	B14	MIPI_CSI_D1_P	2V5	I	MIPI Camera Serial Interface data pair 1 positive signal
X2_41	A14	MIPI_CSI_D1_N	2V5	I	MIPI Camera Serial Interface data pair 1 negative signal

3.5. Audio Interface

The PICO-IMX7 synchronous audio interface (SAI) supports full-duplex serial interfaces with frame synchronization such as I2S, AC97, TDM, and codec/DSP interfaces.

Key features of the audio signal block include:

- Transmitter with independent bit clock and frame sync supporting 1 data line
- Receiver with independent bit clock and frame sync supporting 1 data line
- Maximum Frame Size of 32 words
- Word size of between 8-bits and 32-bits
- Word size configured separately for first word and remaining words in frame
- Asynchronous 32 x 32-bit FIFO for each transmit and receive channel
- Supports graceful restart after FIFO error

For additional details, please refer to the “Synchronous Audio Interface (SAI)” chapter of the “i.MX7 Application Processor Reference Manual”.

Table 13 - I²S Audio Signal Description

PIN	CPU BALL	CPU PAD NAME	Signal	V	I/O	Description
E1_50	D16	ENET1_TX_CLK	SAI1_RX_DATA	1V8	I	Integrated Interchip Sound (I ² S) channel receive data line
E1_52	D15	ENET1_RX_CLK	SAI1_TX_BCLK	1V8	O	Integrated Interchip Sound (I ² S) channel word clock signal
E1_54	E19	ENET1_CRS	SAI1_TX_SYNC	1V8	I/O	Integrated Interchip Sound (I ² S) channel frame synchronization signal
E1_56	D19	ENET1_COL	SAI1_TX_DATA	1V8	O	Integrated Interchip Sound (I ² S) channel transmit data line

3.6. PCI Express

The PICO-IMX7 is equipped with a single lane PCI Express interface.

PCI Express PHY Features

- 1.5 / 2.5 / 3.0 / 5.0 / 6.0 Gbps Serializer / Deserializer
- Compliant with PCI Express Base Specification 2.1
- Compliant with PIPE Specification 2.0
- 8 / 16 / 20 / 40-bit CMOS Interface for Transmitter and Receiver
- 25 / 100 MHz Reference Clock
- K28.5 Detection for Word Alignment
- 8B/10B Encoding / Decoding
- Receiver Detection
- Supports Spread Spectrum Clocking in Transmitter and Receiver

For additional details, please refer to the “PCI Express (PCIe)” chapter of the “i.MX7 Reference Manual”.

Table 14 - USB Host Signal Description

PIN	CPU BALL	CPU PAD NAME	V	I/O	Description
X2_56	AB10	PCIE_REFCLKOUT_P	2V5	O	PCI Express clock differential pair positive signal
X2_58	AC10	PCIE_REFCLKOUT_N	2V5	O	PCI Express clock differential pair negative signal
X2_62	AB11	PCIE_TX_P	2V5	O	PCI Express Transmit output differential pair positive signal
X2_64	AC11	PCIE_TX_N	2V5	O	PCI Express Transmit output differential pair negative signal
X2_68	AD11	PCIE_RX_P	2V5	I	PCI Express Receive input differential pair positive signal
X2_70	AE11	PCIE_RX_N	2V5	I	PCI Express Receive input differential pair negative signal

NOTE: The PCIE_TX pair has decoupling capacitors on the PICO Compute Module valued 10nF

3.7. Universal Serial Bus (USB) Interface

The PICO-IMX7 incorporates a single USB Host controller and an additional USB Host/OTG controller.

Each of the USB controllers provides the following main features:

USB 2.0 Host/OTG Controller

- High-Speed/Full-Speed/Low-Speed OTG core
- HS/FS/LS UTMI compliant interface
- High Speed, Full Speed and Low Speed operation in Host mode (with UTMI transceiver)
- High Speed, and Full Speed operation in Peripheral mode (with UTMI transceiver)
- Hardware support for OTG signaling, session request protocol, and host negotiation protocol
- Support charger detection

USB 2.0 Host Controller

- High-Speed/Full-Speed/Low-Speed Host-Only core
- HS/FS/LS UTMI compliant interface

For additional details, please refer to the “Universal Serial Bus Controller (USB)” chapter of the “i.MX7 Application Processor Reference Manual”.

Table 15 - USB Host Signal Description

PIN	CPU BALL	CPU PAD NAME	Signal	V	I/O	Description
X2_46	A10	USB_OTG2_DN		3V3	I/O	Universal Serial Bus differential pair negative signal
X2_48	B10	USB_OTG2_DP		3V3	I/O	Universal Serial Bus differential pair positive signal
X2_50	C10	USB_OTG2_VBUS		5V	I/O	Universal Serial Bus power
X2_52	M5	UART3_RTS	USB_OTG2_OC	3V3	I	Active low input, to inform USB overcurrent condition (low = overcurrent detected)

Table 16 - USB OTG Signal Description

PIN	CPU BALL	CPU PAD NAME	Signal	V	I/O	Description
E1_3	B7	USB_OTG1_ID	USB_OTG1_ID	3V3	I	USB OTG ID Pin
E1_16	B8	USB_OTG1_DP	USB_OTG1_DP	3V3	I/O	Universal Serial Bus differential pair positive signal
E1_18	A8	USB_OTG1_DN	USB_OTG1_DN	3V3	I/O	Universal Serial Bus differential pair negative signal
E1_19	M1	UART3_RXD	USB_OTG1_OC	1V8	I	Over current detect input pin to monitor USB power over current
E1_20	C8	USB_OTG1_VBUS	USB_OTG1_VBUS	5V	I/O	Universal Serial Bus power
E1_21	M2	UART3_TXD	USB_OTG1_PWR	1V8	O	Universal Serial Bus power enable

NOTE: While using USB OTG in USB HOST mode. The USB_ID pin should have a pull-down resistor to GND.

3.8. SDIO/MMC Interface

The PICO-IMX7 features a MMC / SD / SDIO host interfaces connected to the NXP i.MX7 integrated “Ultra Secured Digital Host Controller” (uSDHC).

The following main features are supported by uSDHC:

- Conforms to the SD Host Controller Standard Specification version 3.0
- Compatible with the MMC System Specification version 4.2/4.3/4.4/4.41/4.5/5.0
- Compatible with the SD Memory Card Specification version 3.0 and supports the Extended Capacity SD Memory Card
- Compatible with the SDIO Card Specification version 3.0
- Designed to work with SD Memory, miniSD Memory, SDIO, miniSDIO, SD Combo, MMC, MMC plus, and MMC RS cards
- Card bus clock frequency up to 208 MHz
- Supports 1-bit / 4-bit SD and SDIO modes, 1-bit / 4-bit / 8-bit MMC modes

The MMC/SD/SDIO host controller can support a single MMC / SD / SDIO card or device.

For additional details, please refer to the “Ultra Secured Digital Host Controller (uSDHC)” chapter of the “i.MX7 Reference Manual”.

Table 17 - SDIO/MMC Interface Signal Description

PIN	CPU BALL	CPU PAD NAME	Signal	V	I/O	Description
E1_58	D20	SD1_CLK	SD1_CLK	1V8	I/O	MMC/SDIO Clock
E1_60	M21	EIM_DA9	EIM_DA9	1V8	I	SD Card detect input (Active low)
E1_62	B21	SD1_CMD	SD1_CMD	1V8	I/O	MMC/SDIO Command
E1_64	E19	SD1_DAT2	SD1_DAT2	1V8	I/O	MMC/SDIO Data bit 2
E1_66	A21	SD1_DAT0	SD1_DAT0	1V8	I/O	MMC/SDIO Data bit 0
E1_68	F18	SD1_DAT3	SD1_DAT3	1V8	I/O	MMC/SDIO Data bit 3
E1_70	C20	SD1_DAT1	SD1_DAT1	1V8	I/O	MMC/SDIO Data bit 1

3.9. CAN BUS Interface signals

The PICO-IMX7 features two CAN bus interfaces. The Flexible Controller Area Network (FLEXCAN) module is a communication controller implementing the CAN protocol according to the CAN 2.0B protocol specification.

The CAN protocol was primarily designed to be used as a vehicle serial data bus meeting the specific requirements of this field: real-time processing, reliable operation in the EMI environment of a vehicle, cost-effectiveness and required bandwidth. The FLEXCAN module is a full implementation of the CAN protocol specification, which supports both standard and extended message frames. 64 Message Buffers are supported.

FlexCAN supports the following main features:

- Compliant with the CAN 2.0B protocol specification
- Programmable bit rate up to 1 Mb/sec

Integration of a CAN Bus transceiver and optional galvanic isolation should be incorporated on your carrier board.

For additional details, please refer to the “Flexible Controller Area Network (FLEXCAN)” chapter of the “i.MX7 Application Processor Reference Manual”.

Table 18 - CAN Bus Signal Description

PIN	CPU BALL	CPU PAD NAME	Signal	V	I/O	Description
X2_19	C11	SAI1_TXC	FLEXCAN1_TX	3V3	O	CAN (controller Area Network) transmit signal
X2_21	E12	SAI1_RXD	FLEXCAN1_RX	3V3	I	CAN (controller Area Network) receive signal
X2_25	E11	SAI1_TXD	FLEXCAN2_TX	3V3	O	CAN (controller Area Network) transmit signal
X2_27	D11	SAI1_TXFS	FLEXCAN2_RX	3V3	I	CAN (controller Area Network) receive signal

3.10. Universal Asynchronous Receiver/Transmitter (UART) Interface

The PICO-IMX7 Universal Asynchronous Receiver/Transmitter (UART) provides serial communication capability with external devices through a level converter.

The i.MX7 processor integrated UARTs support the following features:

- High-speed TIA/EIA-232-F compatible, up to 5.0 Mbit/s.
- Serial IR interface low-speed, IrDA-compatible (up to 115.2 Kbit/s).
- 9-bit or Multidrop mode (RS-485) support (automatic slave address detection).
- 7 or 8 data bits for RS-232 characters or 9 bit RS-485 format, 1 or 2 stop bits.
- Programmable parity (even, odd, and no parity).
- Hardware flow control support for request to send (RTS) and clear to send (CTS) signals
- RXD input and TXD output can be inverted respectively in RS-232/RS-485 mode
- RS-485 driver direction control via CTS signal
- Auto baud rate detection (up to 115.2 Kbit/s)
- Two independent, 32-entry FIFOs for transmit and receive

For additional details, please refer to the “Universal Asynchronous Receiver/Transmitter (UART)” chapter of the “i.MX7 Application Processor Reference Manual”.

Table 19 - UART Signal Description

PIN	CPU BALL	CPU PAD NAME	Signal	V	I/O	Description
E1_22	L1	I2C4_SCL	UART5_RXD	1V8	I	Universal Asynchronous Receive Transmit receive data signal
E1_27	L2	I2C4_SDA	UART5_TXD	1V8	O	Universal Asynchronous Receive Transmit transmit data signal
E1_46	L25	EPDC1_DATA09	UART6_TX_DATA	1V8	O	Universal Asynchronous Receive Transmit transmit data signal
E1_61	M23	EPDC1_DATA08	UART6_RX_DATA	1V8	I	Universal Asynchronous Receive Transmit receive data signal
E1_63	L24	EPDC1_DATA10	UART6_RTS_B	1V8	I	Universal Asynchronous Receive Transmit request to send signal
E1_65	L23	EPDC1_DATA11	UART6_CTS_B	1V8	O	Universal Asynchronous Receive Transmit clear to send signal

NOTE: it is recommended to use the UART5 interface as system debug where possible and use the UART6 signals in applications where one serial port is required.

3.11. Serial Peripheral Interface (SPI)

The PICO-IMX7 features an Enhanced Configurable Serial Peripheral Interface (ECSPI) full-duplex, synchronous, four-wire serial communication block.

The following main features are supported:

- Full-duplex synchronous serial interface
- Master/Slave configurable
- Transfer continuation function allows unlimited length data transfers
- 32-bit wide by 64-entry FIFO for both transmit and receive data
- Polarity and phase of the Chip Select (SS) and SPI Clock (SCLK) are configurable
- Direct Memory Access (DMA) support
- Max operation frequency up to the reference clock frequency.

For additional details, please refer to the “Enhanced Configurable SPI (ECSPI)” chapter of the “i.MX7 Application Processor Reference Manual”.

Table 20 - SPI Channel Signal Description

PIN	CPU BALL	CPU PAD NAME	Signal	V	I/O	Description
E1_53	K3	I2C2_SDA	ECSPI3_SS0	1V8	O	Serial Peripheral Interface Chip Select signal
E1_55	K2	I2C2_SCL	ECSPI3_SCLK	1V8	I/O	Serial Peripheral Interface clock signal
E1_57	K1	I2C1_SDA	ECSPI3_MOSI	1V8	I/O	Serial Peripheral Interface master output slave input signal
E1_59	J2	I2C1_SCL	ECSPI3_MISO	1V8	I/O	Serial Peripheral Interface master input slave output signal

3.12. I²C Bus

The PICO-IMX7 incorporates several I²C interfaces. I²C is a two-wire, bidirectional serial bus that provides a simple, efficient method of data exchange, minimizing the interconnection between devices. This bus is suitable for applications requiring occasional communications over a short distance between many devices.

The following features are supported:

- Compliance with Philips I²C specification version 2.1
- Multiple-master operation
- Support for standard mode (up to 100K bits/s) and fast mode (up to 400K bits/s)
- Arbitration-lost interrupt with automatic mode switching from master to slave

For additional details, please refer to the “I²C Controller (I2C)” chapter of the “i.MX7 Application Processor Reference Manual”.

Table 21 - I²C Bus Signal Description

PIN	CPU BALL	CPU PAD NAME	Signal	V	I/O	Description
E1_41	L3	UART1_RXD	I2C1_SCL	1V8	I/O	I ² C bus clock line
E1_43	L4	UART1_TXD	I2C1_SDA	1V8	I/O	I ² C bus data line
E1_45	L5	UART2_RXD	I2C2_SCL	1V8	I/O	I ² C bus clock line
E1_47	L6	UART2_TXD	I2C2_SDA	1V8	I/O	I ² C bus data line
X2_13	C12	SAI1_RXFS	I2C4_SCL	3V3	I/O	I ² C bus clock line
X2_15	D12	SAI1_RXC	I2C4_SDA	3V3	I/O	I ² C bus data line

NOTE: All 1V8 I²C bus data and clock lines for all I²C interfaces have 2.2K Ω pull-up resistors present on the PICO-IMX7 module.

NOTE: All 3V3 I²C bus data and clock lines for all I²C interfaces have 1.5K Ω pull-up resistors present on the PICO-IMX7 module.

3.13. General Purpose Input/Output (GPIO)

The PICO-7 has 10 dedicated GPIO pins at 1.8V and 3 dedicated GPIO at 3.3V. Many of the other pins used on the PICO Compute Module can be put in GPIO module however doing so might break scalability with other PICO Compute Modules.

The GPIO signals can be configured for the following applications:

- Data input / output
- Interrupt generation

For additional details, please refer to the “General Purpose Input/Output (GPIO)” chapter of the “i.MX7 Application Processor Reference Manual”.

Table 22 - GPIO Signal Description

PIN	CPU BALL	CPU PAD NAME	Signal	V	I/O	Description
E1_24	P20	EPDC1_DATA00	GPIO2_IO00	1V8	I/O	General Purpose Input Output
E1_25	M21	EPDC_D06	GPIO2_IO06	1V8	I/O	General Purpose Input Output
E1_26	P21	EPDC1_D01	GPIO2_IO01	1V8	I/O	General Purpose Input Output
E1_28	N20	EPDC1_D02	GPIO2_IO02	1V8	I/O	General Purpose Input Output
E1_30	N21	EPDC1_D03	GPIO2_IO03	1V8	I/O	General Purpose Input Output
E1_32	N22	EPDC1_D04	GPIO2_IO04	1V8	I/O	General Purpose Input Output
E1_34	M20	EPDC1_D05	GPIO2_IO05	1V8	I/O	General Purpose Input Output
E1_42	L22	EPDC1_D12	GPIO2_IO12	1V8	I/O	General Purpose Input Output
E1_44	L21	EPDC1_D13	GPIO2_IO13	1V8	I/O	General Purpose Input Output
E1_48	M22	EPDC1_D07	GPIO2_IO07	1V8	I/O	General Purpose Input Output
X2_65	P1	GPIO1_IO05	GPIO1_IO05	3V3	I/O	General Purpose Input Output
X2_67	N6	GPIO1_IO04	GPIO1_IO04	3V3	I/O	General Purpose Input Output
X2_69	N3	GPIO1_IO02	GPIO1_IO02	3V3	I/O	General Purpose Input Output

3.14. Pulse Width Modulation (PWM)

The PICO-IMX7 has 4 dedicated PWM pins at 1.8V and 1 PWM for LCD brightness control at 3.3V.

The following features characterize the PWM:

- 16-bit up-counter with clock source selection
- 4 x 16 FIFO to minimize interrupt overhead
- 12-bit prescaler for division of clock
- Sound and melody generation
- Active high or active low configured output
- Can be programmed to be active in low-power mode
- Can be programmed to be active in debug mode
- Interrupts at compare and rollover

For additional details, please refer to the “Pulse Width Modulation (PWM)” chapter of the “i.MX7 Application Processor Reference Manual”.

Table 23 - PWM Signal Description

PIN	CPU BALL	CPU PAD NAME	Signal	V	I/O	Description
E1_33	R1	GPIO1_IO08	PWM1_OUT	1V8	O	General Purpose Input Output with PWM control
E1_35	R2	GPIO1_IO09	PWM2_OUT	1V8	O	General Purpose Input Output with PWM control
E1_37	R5	GPIO1_IO10	PWM3_OUT	1V8	O	General Purpose Input Output with PWM control
E1_39*	T1	GPIO1_IO11	PWM4_OUT	1V8	O	General Purpose Input Output with PWM control
X1_66*	T1	GPIO1_IO11	PWM4_OUT	3V3	O	LCD Backlight brightness Control

3.15. Manufacturing and Boot Control

The PICO-IMX7 has a number of pins to override the default boot media present on the PICO-IMX7 Compute Module or enable debug serial loader functionality.

Table 24 - Boot Selection Pins

PIN	CPU BALL	CPU PAD NAME	Signal	V	I/O	Description
X2_3	G20	BT_CFG11	BT_CFG11	1V8	I	Boot Select pin
X2_5	C22	BT_CFG4	BT_CFG4	1V8	I	Boot Select pin
X2_7	F21	BT_CFG12	BT_CFG12	1V8	I	Boot Select pin
X2_9	E22	BT_CFG13	BT_CFG13	1V8	I	Boot Select pin

3.15.1. Boot Modes

The PICO-IMX7 Compute Module automatically boot from the internal eMMC if the above signals keep floating. Only when Serial Downloader Mode is required the signals need to be connected as

Table 25 - Serial Downloader Boot Mode Configuration below.

Table 25 - Serial Downloader Boot Mode Configuration

PIN	CPU BALL	Serial Downloader Mode
X2_3	G20	HIGH
X2_5	C22	LOW
X2_7	F21	Not Connected
X2_9	E22	Not Connected

Table 26 - Internal Downloader Boot Mode Configuration

PIN	CPU BALL	Internal (eMMC) Boot Mode
X2_3	G20	LOW
X2_5	C22	HIGH
X2_7	F21	Not Connected
X2_9	E22	Not Connected

3.16. Input Power Requirements

The PICO-IMX7 is designed to be driven with a single input power rail.

The power domain pins have to be connected as follow:

- All GND pins have to be connected to the carrier board ground pane.
- All VSYS pins should be connected to the main power source.

Table 27 - Input Power Signals

Power Rail	Nominal Input	Input Range	Maximum Input Ripple
VSYS (4 pin)	5V	+4.2V - +5.25V	±50 mV

3.16.1. Power Management Signals

The PICO-IMX7 has the following set of signals to control the system power states such as the power-on and reset conditions. This enables the system designer to implement a fully ACPI compliant system supporting system states.

Table 28 - Power Management Signals

PIN	CPU BALL	CPU PAD NAME	Signal	V	I/O	Description
E1_17	AC8	ONOFF	ONOFF	3V3	I	Power ON button input signal
E1_36	PMIC	RESET	RESET	1V8	I	Reset power signal

NOTE: Pin E1_36 is described in detail in **chapter 2.2. Power Management IC** of this manual

3.16.2. Power Sequence

PICO-IMX7 input power sequencing requirements are as follow:

If a backup Real Time Clock (RTC) is required in the host system. We recommend to design an RTC circuit on the PICO carrier board. For example the Maxim Integrated DS1337+ connected over the general purpose I²C can be used.

Start Sequence:

VCC_RTC must come up at the same time or before VCC comes up.

Stop Sequence:

VCC must go down at the same time or before VCC_RTC goes down

Table 29 - Input Power Sequencing

Item	Description	Value
T1	VCC_RTC rise to VCC rise	≥ 0 ms
T2	VCC fall to VCC_RTC fall	≥ 0 ms

Figure 14 - Input Power sequence

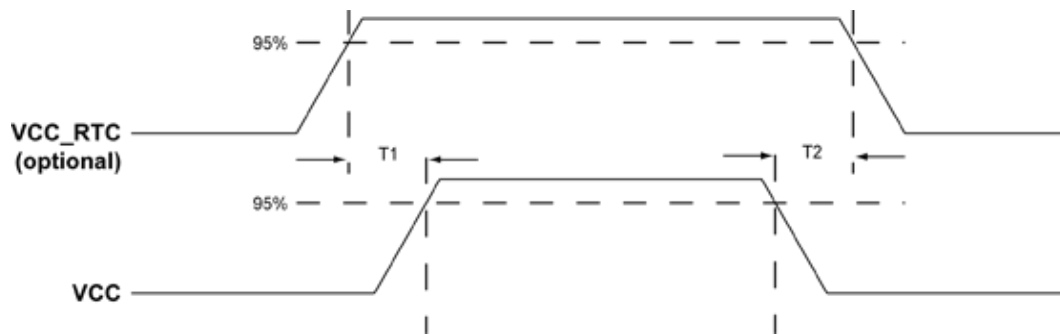

4. PICO Compute Module Pin Assignment

The PICO-IMX7 has three 70-pin Hirose board to board connectors.

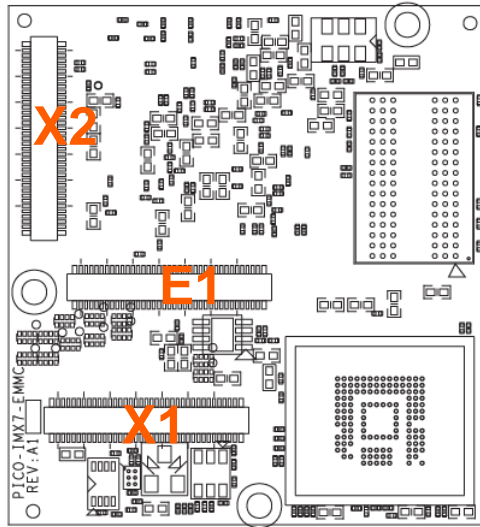

PIN	CPU BALL	CPU PAD NAME	Signal	V	I/O	Description
E1_1			GND		P	Ground
E1_2			VSYS		P	System input power (4.0 to 5.25V)
E1_3	B7	USB_OTG1_ID	USB_OTG1_ID	3V3	I	USB OTG ID Pin
E1_4			VSYS		P	System input power (4.0 to 5.25V)
E1_5			GND		P	Ground
E1_6			VSYS		P	System input power (4.0 to 5.25V)
E1_7	N5	CLK_32K_OUT	CLK_32K_OUT	3V3		
E1_8			3V3		P	System 3.3V Output
E1_9			GND		P	Ground
E1_10			3V3		P	System 3.3V Output
E1_11			GND		P	Ground
E1_12			1V8		P	System 1.8V Output (same as E1 connector I/O voltage levels)
E1_13			GND		P	Ground
E1_14			VSYS		P	System input power (4.0 to 5.25V)
E1_15			GND		P	Ground
E1_16	B8	USB_OTG1_DP	USB_OTG1_DP	3V3	I/O	Universal Serial Bus differential pair positive signal

PIN	CPU BALL	CPU PAD NAME	Signal	V	I/O	Description
E1_17	AC8	ONOFF	ONOFF	3V3	I	Power ON button input signal
E1_18	A8	USB_OTG1_DN	USB_OTG1_DN	3V3	I/O	Universal Serial Bus differential pair negative signal
E1_19	M1	UART3_RXD	USB_OTG1_OC	1V8	I	Over current detect input pin to monitor USB power over current
E1_20	C8	USB_OTG1_VBUS	USB_OTG1_VBUS	5V	I/O	Universal Serial Bus power
E1_21	M2	UART3_TXD	USB_OTG1_PWR	1V8	O	Universal Serial Bus power enable
E1_22	L1	I2C4_SCL	UART5_RXD	1V8	I	Universal Asynchronous Receive Transmit receive data signal
E1_23			VCC_RTC	3V3	P	RTC Power
E1_24	P20	EPDC1_DATA00	GPIO2_IO00	1V8	I/O	General Purpose Input Output
E1_25	M21	EPDC_D06	GPIO2_IO06	1V8	I/O	General Purpose Input Output
E1_26	P21	EPDC1_D01	GPIO2_IO01	1V8	I/O	General Purpose Input Output
E1_27	L2	I2C4_SDA	UART5_TXD	1V8	O	Universal Asynchronous Receive Transmit transmit data signal
E1_28	N20	EPDC1_D02	GPIO2_IO02	1V8	I/O	General Purpose Input Output
E1_29			NC			Not Connected
E1_30	N21	EPDC1_D03	GPIO2_IO03	1V8	I/O	General Purpose Input Output
E1_31			NC			Not Connected
E1_32	N22	EPDC1_D04	GPIO2_IO04	1V8	I/O	General Purpose Input Output
E1_33	R1	GPIO1_IO08	PWM1_OUT	1V8	O	General Purpose Input Output with PWM control
E1_34	M20	EPDC1_D05	GPIO2_IO05	1V8	I/O	General Purpose Input Output
E1_35	R2	GPIO1_IO09	PWM2_OUT	1V8	O	General Purpose Input Output with PWM control
E1_36	PMIC	RESET	RESET	1V8	I	Reset power signal
E1_37	R5	GPIO1_IO10	PWM3_OUT	1V8	O	General Purpose Input Output with PWM control
E1_38			NC			Not Connected
E1_39	T1	GPIO1_IO11	PWM4_OUT	1V8	O	General Purpose Input Output with PWM control
E1_40			NC			Not Connected
E1_41	L3	UART1_RXD	I2C1_SCL	1V8	I/O	I ² C bus clock line
E1_42	L22	EPDC1_D12	GPIO2_IO12	1V8	I/O	General Purpose Input Output
E1_43	L4	UART1_TXD	I2C1_SDA	1V8	I/O	I ² C bus data line
E1_44	L21	EPDC1_D13	GPIO2_IO13	1V8	I/O	General Purpose Input Output
E1_45	L5	UART2_RXD	I2C2_SCL	1V8	I/O	I ² C bus clock line

PIN	CPU BALL	CPU PAD NAME	Signal	V	I/O	Description
E1_46	L25	EPDC1_DATA09	UART6_TX_DATA	1V8	O	Universal Asynchronous Receive Transmit transmit data signal
E1_47	L6	UART2_TXD	I2C2_SDA	1V8	I/O	I ² C bus data line
E1_48	M22	EPDC1_D07	GPIO2_IO07	1V8	I/O	General Purpose Input Output
E1_49			NC			Not Connected
E1_50	D16	ENET1_TX_CLK	SAI1_RX_DATA	1V8	I	Integrated Interchip Sound (I ² S) channel receive data line
E1_51	M6	UART3_CTS	ECSPI1_SS0	1V8	O	Serial Peripheral Interface Chip Select Signal
E1_52	D15	ENET1_RX_CLK	SAI1_TX_BCLK	1V8	O	Integrated Interchip Sound (I ² S) channel word clock signal
E1_53	K3	I2C2_SDA	ECSPI3_SS0	1V8	O	Serial Peripheral Interface Chip Select signal
E1_54	E19	ENET1_CRS	SAI1_TX_SYNC	1V8	I/O	Integrated Interchip Sound (I ² S) channel frame synchronization signal
E1_55	K2	I2C2_SCL	ECSPI3_SCLK	1V8	I/O	Serial Peripheral Interface clock signal
E1_56	D19	ENET1_COL	SAI1_TX_DATA	1V8	O	Integrated Interchip Sound (I ² S) channel transmit data line
E1_57	K1	I2C1_SDA	ECSPI3_MOSI	1V8	I/O	Serial Peripheral Interface master output slave input signal
E1_58	B5	SD1_CLK	SD1_CLK	1V8	I/O	MMC/SDIO Clock
E1_59	J2	I2C1_SCL	ECSPI3_MISO	1V8	I/O	Serial Peripheral Interface master input slave output signal
E1_60	C6	SD1_CD_B	SD1_CD_B	1V8	I	SD Card detect input (Active low)
E1_61	M23	EPDC1_DATA08	UART6_RX_DATA	1V8	I	Universal Asynchronous Receive Transmit receive data signal
E1_62	C5	SD1_CMD	SD1_CMD	1V8	I/O	MMC/SDIO Command
E1_63	L24	EPDC1_DATA10	UART6_RTS_B	1V8	I	Universal Asynchronous Receive Transmit request to send signal
E1_64	A4	SD1_DATA2	SD1_DATA2	1V8	I/O	MMC/SDIO Data bit 2
E1_65	L23	EPDC1_DATA11	UART6_CTS_B	1V8	O	Universal Asynchronous Receive Transmit clear to send signal
E1_66	A5	SD1_DATA0	SD1_DATA0	1V8	I/O	MMC/SDIO Data bit 0
E1_67			NC			Not Connected
E1_68	D5	SD1_DATA3	SD1_DATA3	1V8	I/O	MMC/SDIO Data bit 3
E1_69			NC			Not Connected
E1_70	D6	SD1_DATA1	SD1_DATA1	1V8	I/O	MMC/SDIO Data bit 1

PIN	CPU BALL	CPU PAD NAME	Signal	V	I/O	Description
X1_1			GND		P	Ground
X1_2			GND		P	Ground
X1_3			NC			Not Connected
X1_4			NC			Not Connected
X1_5			NC			Not Connected
X1_6			NC			Not Connected
X1_7			GND		P	Ground
X1_8	G23	LCD1_DATA23	LCD_DATA23	3V3	O	LCD Pixel Data bit 23
X1_9			NC			Not Connected
X1_10	D25	LCD1_DATA22	LCD_DATA22	3V3	O	LCD Pixel Data bit 22
X1_11			NC			Not Connected
X1_12	E24	LCD1_DATA21	LCD_DATA21	3V3	O	LCD Pixel Data bit 21
X1_13			GND		P	Ground
X1_14	C25	LCD1_DATA20	LCD_DATA20	3V3	O	LCD Pixel Data bit 20
X1_15			NC			Not Connected
X1_16	D24	LCD1_DATA19	LCD_DATA19	3V3	O	LCD Pixel Data bit 19
X1_17			NC			Not Connected
X1_18	E23	LCD1_DATA18	LCD_DATA18	3V3	O	LCD Pixel Data bit 18
X1_19			GND		P	Ground
X1_20	G21	LCD1_DATA17	LCD_DATA17	3V3	O	LCD Pixel Data bit 17
X1_21			NC			Not Connected
X1_22	B25	LCD1_DATA16	LCD_DATA16	3V3	O	LCD Pixel Data bit 16
X1_23			NC			Not Connected
X1_24	C24	LCD1_DATA15	LCD_DATA15	3V3	O	LCD Pixel Data bit 15
X1_25			GND		P	Ground
X1_26	D23	LCD1_DATA14	LCD_DATA14	3V3	O	LCD Pixel Data bit 14
X1_27			NC			Not Connected
X1_28	E22	LCD1_DATA13	LCD_DATA13	3V3	O	LCD Pixel Data bit 13
X1_29			NC			Not Connected
X1_30	F21	LCD1_DATA12	LCD_DATA12	3V3	O	LCD Pixel Data bit 12
X1_31			GND		P	Ground
X1_32	G20	LCD1_DATA11	LCD_DATA11	3V3	O	LCD Pixel Data bit 11
X1_33	C3	SD2_WP	ENET1_MDC	3V3		Management data clock reference
X1_34	B24	LCD1_DATA10	LCD_DATA10	3V3	O	LCD Pixel Data bit 10
X1_35	D3	SD2_CD_B	ENET1_MDIO	3V3		Management data
X1_36	C23	LCD1_DATA09	LCD_DATA09	3V3	O	LCD Pixel Data bit 9
X1_37	G1	SD3_RESET_B	GPIO6_IO11	3V3		Ethernet reset
X1_38	E21	LCD1_DATA08	LCD_DATA08	3V3	O	LCD Pixel Data bit 8
X1_39	J1	SD3_STROBE	GPIO6_IO10	3V3		Ethernet interrupt output
X1_40	F20	LCD1_DATA07	LCD_DATA07	3V3	O	LCD Pixel Data bit 7
X1_41	N2	GPIO1_IO01	CCM_ENET_REF_CLK3	3V3		Synchronous Ethernet recovered clock
X1_42	A24	LCD1_DATA06	LCD_DATA06	3V3	O	LCD Pixel Data bit 6
X1_43	E16	ENET1_TX_CTL	RGMII1_TX_CTL	1V8	O	RGMII transmit enable
X1_44	B23	LCD1_DATA05	LCD_DATA05	3V3	O	LCD Pixel Data bit 5
X1_45	E15	ENET1_RX_CTL	RGMII1_RX_CTL	1V8	I	RGMII receive data valid
X1_46	C22	LCD1_DATA04	LCD_DATA04	3V3	O	LCD Pixel Data bit 4

PIN	CPU BALL	CPU PAD NAME	Signal	V	I/O	Description
X1_47			GND		P	Ground
X1_48	A23	LCD1_DATA03	LCD_DATA03	3V3	O	LCD Pixel Data bit 3
X1_49	F16	ENET1_TXC	RGMII1_TXC	1V8	O	RGMII transmit clock
X1_50	B22	LCD1_DATA02	LCD_DATA02	3V3	O	LCD Pixel Data bit 2
X1_51	F17	ENET1_TDATA0	RGMII1_TD0	1V8	O	RGMII transmit data 0
X1_52	A22	LCD1_DATA01	LCD_DATA01	3V3	O	LCD Pixel Data bit 1
X1_53	E17	ENET1_TDATA1	RGMII1_TD1	1V8	O	RGMII transmit data 1
X1_54	D21	LCD1_DATA00	LCD_DATA00	3V3	O	LCD Pixel Data bit 0
X1_55	E18	ENET1_TDATA2	RGMII1_TD2	1V8	O	RGMII transmit data 2
X1_56	C21	LCD1_RESET	LCD_RS	3V3	O	LCD backlight enable/disable
X1_57	D18	ENET1_TDATA3	RGMII1_TD3	1V8	O	RGMII transmit data 3
X1_58	E25	LCD1_HSYNC	LCD_HSYNC	3V3	O	LCD Horizontal Synchronization
X1_59			GND		P	Ground
X1_60	F25	LCD1_ENABLE	LCD_ENABLE	3V3	O	LCD dot enable pin signal
X1_61	F15	ENET1_RXC	RGMII1_RXC	1V8	I	RGMII receive clock
X1_62	F24	LCD1_VSYNC	LCD_VSYNC	3V3	O	LCD Vertical Synchronization
X1_63	E14	ENET1_RDATA0	RGMII1_RD0	1V8	I	RGMII transmit data 0
X1_64	E20	LCD1_CLK	LCD_CLK	3V3	O	LCD Pixel Clock
X1_65	F14	ENET1_RDATA1	RGMII1_RD1	1V8	I	RGMII receive data 1
X1_66	T1	GPIO1_IO11	PWM4_OUT	3V3	O	LCD Backlight brightness Control
X1_67	D13	ENET1_RDATA2	RGMII1_RD2	1V8	I	RGMII receive data 2
X1_68	P2	GPIO1_IO06	GPIO1_IO06	3V3	O	LCD Voltage On
X1_69	E13	ENET1_RDATA3	RGMII1_RD3	1V8	I	RGMII receive data 3
X1_70			GND		P	Ground

PIN	CPU BALL	CPU PAD NAME	Signal	V	I/O	Description
X2_1			GND		P	Ground
X2_2			GND		P	Ground
X2_3	G20	BT_CFG11	BT_CFG11	1V8	I	Boot Select pin
X2_4			NC			Not Connected
X2_5	C22	BT_CFG4	BT_CFG4	1V8	I	Boot Select pin
X2_6			NC			Not Connected
X2_7	F21	BT_CFG12	BT_CFG12	1V8	I	Boot Select pin
X2_8			GND		P	Ground
X2_9	E22	BT_CFG13	BT_CFG13	1V8	I	Boot Select pin
X2_10			NC			Not Connected
X2_11			GND		P	Ground
X2_12			NC			Not Connected
X2_13	C12	SAI1_RXFS	I2C4_SCL	3V3	I/O	I ² C bus clock line
X2_14			GND		P	Ground
X2_15	D12	SAI1_RXC	I2C4_SDA	3V3	I/O	I ² C bus data line
X2_16			NC			Not Connected
X2_17			GND		P	Ground
X2_18			NC			Not Connected
X2_19	C11	SAI1_TXC	FLEXCAN1_TX	3V3	O	CAN (controller Area Network) transmit signal
X2_20			GND		P	Ground
X2_21	E12	SAI1_RXD	FLEXCAN1_RX	3V3	I	CAN (controller Area Network) receive signal
X2_22			NC			Not Connected
X2_23			GND		P	Ground
X2_24			NC			Not Connected
X2_25	E11	SAI1_TXD	FLEXCAN2_TX	3V3	O	CAN (controller Area Network) transmit signal
X2_26			GND		P	Ground
X2_27	D11	SAI1_TXFS	FLEXCAN2_RX	3V3	I	CAN (controller Area Network) receive signal
X2_28			NC			Not Connected
X2_29			GND		P	Ground
X2_30			NC			Not Connected
X2_31	A15	MIPI_CSI_CLK_N		2V5	I	MIPI Camera Serial Interface clock pair negative signal
X2_32			GND		P	Ground
X2_33	B15	MIPI_CSI_CLK_P		2V5	I	MIPI Camera Serial Interface clock pair positive signal
X2_34			NC			Not Connected
X2_35	A16	MIPI_CSI_D0_N		2V5	I	MIPI Camera Serial Interface data pair 0 negative signal
X2_36			NC			Not Connected
X2_37	B16	MIPI_CSI_D0_P		2V5	I	MIPI Camera Serial Interface data pair 0 positive signal
X2_38			GND		P	Ground
X2_39	B14	MIPI_CSI_D1_P		2V5	I	MIPI Camera Serial Interface data pair 1 positive signal
X2_40			NC			Not Connected

PIN	CPU BALL	CPU PAD NAME	Signal	V	I/O	Description
X2_41	A14	MIPI_CSI_D1_N		2V5	I	MIPI Camera Serial Interface data pair 1 negative signal
X2_42			NC			Not Connected
X2_43			NC			Not Connected
X2_44			GND		P	Ground
X2_45			NC			Not Connected
X2_46	A10	USB_OTG2_DN		3V3	I/O	Universal Serial Bus differential pair negative signal
X2_47			NC			Not Connected
X2_48	B10	USB_OTG2_DP		3V3	I/O	Universal Serial Bus differential pair positive signal
X2_49			NC			Not Connected
X2_50	C10	USB_OTG2_VBUS		5V	I/O	Universal Serial Bus power
X2_51			GND		P	Ground
X2_52	M5	UART3_RTS	USB_OTG2_OC	3V3	I	Active low input, to inform USB overcurrent condition (low = overcurrent detected)
X2_53	B20	MIPI_DSI_D0_P		2V5	O	MIPI Display Serial Interface data pair 0 positive signal
X2_54			GND		P	Ground
X2_55	A20	MIPI_DSI_D0_N		2V5	O	MIPI Display Serial Interface data pair 0 negative signal
X2_56	AB10	PCIE_REFCLKOUT_P		2V5	O	PCI Express clock differential pair positive signal
X2_57	B18	MIPI_DSI_D1_P		2V5	O	MIPI Display Serial Interface data pair 1 positive signal
X2_58	AC10	PCIE_REFCLKOUT_N		2V5	O	PCI Express clock differential pair negative signal
X2_59	A18	MIPI_DSI_D1_N		2V5	O	MIPI Display Serial Interface data pair 1 negative signal
X2_60			GND		P	Ground
X2_61	A19	MIPI_DSI_CLK_N		2V5	O	MIPI Display Serial Interface clock pair negative signal
X2_62	AB11	PCIE_TX_P		2V5	O	PCI Express Transmit output differential pair positive signal
X2_63	B19	MIPI_DSI_CLK_P		2V5	O	MIPI Display Serial Interface clock pair positive signal
X2_64	AC11	PCIE_TX_N		2V5	O	PCI Express Transmit output differential pair negative signal
X2_65	P1	GPIO1_IO05	GPIO1_IO05	3V3	I/O	General Purpose Input Output

PIN	CPU BALL	CPU PAD NAME	Signal	V	I/O	Description
X2_66			GND		P	Ground
X2_67	N6	GPIO1_IO04	GPIO1_IO04	3V3	I/O	General Purpose Input Output
X2_68	AD11	PCIE_RX_P		2V5	I	PCI Express Receive input differential pair positive signal
X2_69	N3	GPIO1_IO02	GPIO1_IO02	3V3	I/O	General Purpose Input Output
X2_70	AE11	PCIE_RX_N		2V5	I	PCI Express Receive input differential pair negative signal

5. Ordering Information

TechNexion provides a complete product portfolio for the PICO-IMX7 to assist our customers to evaluate, proto-type, integrate and mass produce solutions with our PICO Compute Modules.

5.1. PICO Compute Module Product Ordering Part Numbers

The PICO-IMX7 is available in a number of standard configurations. Custom tailored versions with other memory configuration, de-population of interfaces or extended and industrial temperature options are available upon request.

5.1.1 Standard Part Numbers

Standard part numbers can be easily found on the PICO-IMX7 product page on the TechNexion corporate homepage.

5.4.2. Custom Part Number Creation Rules

The PICO-IMX7 can be ordered in custom tailored to meet special application requirements and conditions according to the following custom part number creation rules.

Custom part numbers carry minimum order quantities. Please connect with your TechNexion representative for conditions and availability.

Part number format:

PICO-IMX7x-R20-E04-BW-xx-xxxx

Interface	Code	Description
Processor	S	i.MX7 Solo
	D	i.MX7 Dual
Memory	R05	512 MB DDR3
	R10	1GB DDR3
	R20	2GB DDR3
Storage	MSD	MicroSD Cardslot
	E04	eMMC 4GB (Default)
	Exx	Other capacities of eMMC are possible (8GB, 16GB, 32GB, 64GB)
Wireless Networking	-	No
	BB	802.11bgn + Bluetooth 4.1 (BCM43438)
	BW	802.11ac + Bluetooth 4.1 (BCM4339)
Temperature Range	-	Commercial Temperature range (0~60°C) (Default)
	TE	Extended Temperature range (-20~70°C)
	TI	Industrial Temperature range (-35~85°C)
Custom ID	XXXX	Custom Partnumber ID for customized software loader and special component (BOM)

NOTE: Wireless Networking option is not available in “TI” Industrial Temperature Range.

6. Important Notice

TechNexion reserve the right to make corrections, modifications, enhancements, improvements, and other changes to its products and services at any time and to discontinue any product or service without notice. Customers should obtain the latest relevant information before placing orders and should verify that such information is current and complete. All products are sold subject to TechNexion terms and conditions of sale supplied at the time of order acknowledgment.

TechNexion warrants performance of its hardware products to the specifications applicable at the time of sale in accordance with TechNexion's standard warranty. Testing and other quality control techniques are used to the extent TechNexion deems necessary to support this warranty. Except where mandated by government requirements, testing of all parameters of each product is not necessarily performed.

TechNexion assumes no liability for applications assistance or customer product design. Customers are responsible for their products and applications using TechNexion components. To minimize the risks associated with customer products and applications, customers should provide adequate design and operating safeguards.

TechNexion does not warrant or represent that any license, either express or implied, is granted under any TechNexion patent right, copyright, mask work right, or other TechNexion intellectual property right relating to any combination, machine, or process in which TechNexion products or services are used. Information published by TechNexion regarding third-party products or services does not constitute a license from TechNexion to use such products or services or a warranty or endorsement thereof. Use of such information may require a license from a third party under the patents or other intellectual property of the third party, or a license from TechNexion under the patents or other intellectual property of TechNexion.

TechNexion products are not authorized for use in safety-critical applications (such as life support) where a failure of the TechNexion product would reasonably be expected to cause severe personal injury or death, unless officers of the parties have executed an agreement specifically governing such use. Buyers represent that they have all necessary expertise in the safety and regulatory ramifications of their applications, and acknowledge and agree that they are solely responsible for all legal, regulatory and safety-related requirements concerning their products and any use of TechNexion products in such safety-critical applications, notwithstanding any applications-related information or support that may be provided by TechNexion. Further, Buyers must fully indemnify TechNexion and its representatives against any damages arising out of the use of TechNexion products in such safety-critical applications.

TechNexion products are neither designed nor intended for use in military/aerospace applications or environments unless the TechNexion products are specifically designated by TechNexion as military grade or "enhanced plastic." Only products designated by TechNexion as military-grade meet military specifications. Buyers acknowledge and agree that any such use of TechNexion products which TechNexion has not designated as military-grade is solely at the Buyer's risk, and that they are solely responsible for compliance with all legal and regulatory requirements in connection with such use.

TechNexion products are neither designed nor intended for use in automotive applications or environments unless the specific TechNexion products are designated by TechNexion as compliant with ISO/TS 16949 requirements. Buyers acknowledge and agree that, if they use any non-designated products in automotive applications, TechNexion will not be responsible for any failure to meet such requirements.