

PICO-IMX8M



- The PICO-IMX8M is a System on Module (SOM) based on an NXP i.MX8M Quad core Cortex-A53™ + M4™ processor clocking up to 1.5GHz.
- The PICO-IMX8M operates in commercial and industrial temperature ranges from -40 to 85°C. The on-board Vivante GC7000Lite GPU OpenGL® ES 3.1, OpenGL® 3.0, Vulkan®, OpenCL™ 1.2 yield superb 4K HDR content on HDMI and MIPI-DSI display complementing 2 MIPI-CSI2 camera interfaces.
- The PICO-IMX8M is a member of the TechNexion “PICO pin-to-pin” product family, providing scalable embedded solutions targeting pixel rich and audio applications.
- Accelerate your time-to-market and reduce development costs with TechNexion pre-certified FCC / IC / CE / RCM / TELEC dual-band Wi-Fi 802.11 ac/a/b/g/n, Bluetooth.
- Linux, Yocto, Android runtime images and full source code available.

Specifications



yocto
PROJECT



Core System

Processor	NXP i.MX8M Quad
Processor Speed	up to 1.5GHz
Architecture	ARM Cortex-A53 + M4
PMIC	RoHM BD71837
Memory	up to 4GB LPDDR4
Storage	eMMC
Board-to-Board Connector	Edison compatible connector PICO 70-pin Hirose connectors
System on Module	PICO SOM

Connectivity

Network LAN	RGMII
Wi-Fi/Bluetooth	Qualcomm QCA9377
Antenna	802.11 a/b/g/n/ac + BT (BR+EDR+BLE) MHF4 connector

Signaling

I/O	HDMI	I ² S
	MIPI CSI	UART
	MIPI DSI	SPI
	RGMII	I ² C
	PCIe	PWM
	USB	GPIO
	USB OTG	

Video

Graphic Engine	Vivante GC7000Lite
Video Decode	4K UltraHD HDR 4Kp60 H.265 VP9
Camera	MIPI CSI (4 lanes)

Audio

Audio Codec	On carrier board
Audio Interface	I ² S (2 channel)

Operation Systems

Standard Support	Linux Yocto Android
------------------	---------------------------

Certification and Compliance

USA	FCC ID: 2AKZA-QCA9377
Canada	IC: 22364-QCA9377
Japan	TELEC: 201-180629
European Union	EN 55032 / EN 55024 EN 300 328 v2.1.1 EN 301 893 v2.1.1
Australia/New Zealand	RCM
Bluetooth Logo Certification	QDID150839 (Bluetooth 4.2) Compliant with RoHS / REACH directives

Block Diagram

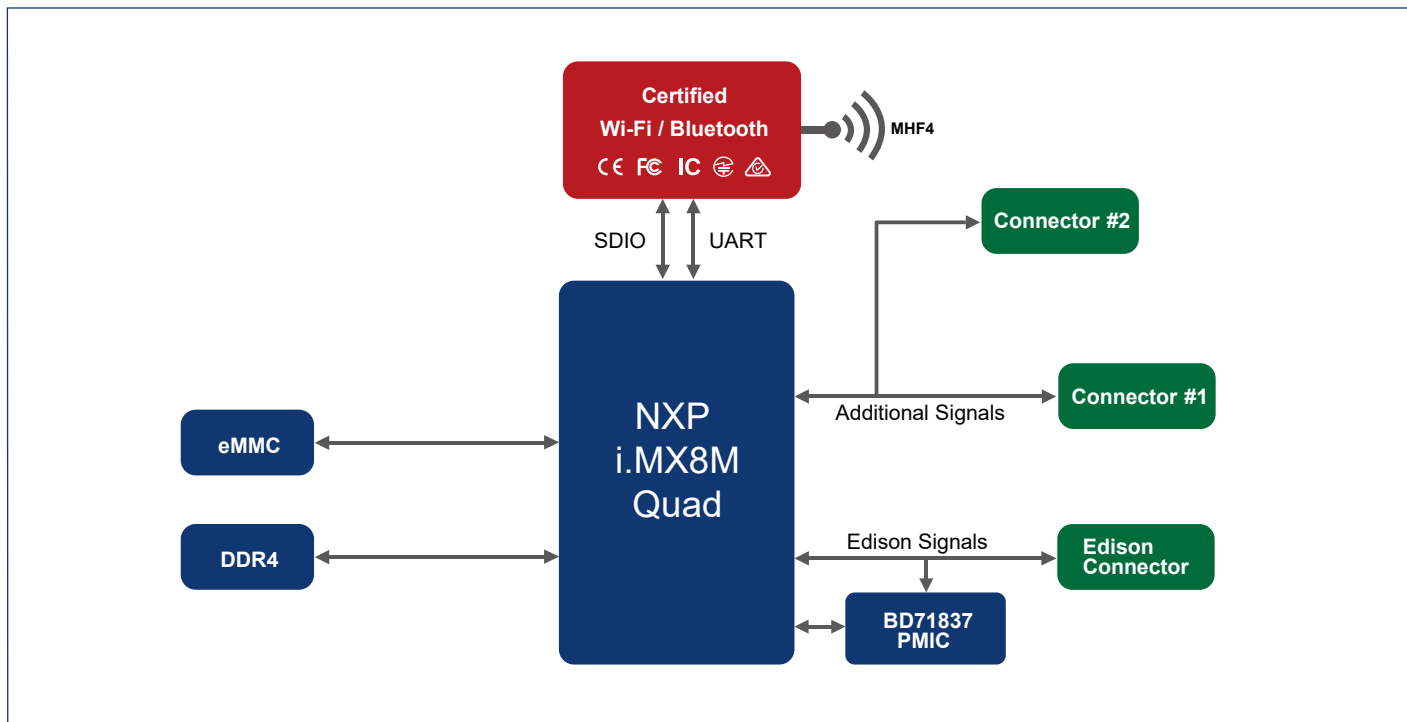

Environmental and Mechanical

Dimensions	37 x 40 mm / 1 3/8 x 1 5/8 inch
Form Factor	PICO Compute Module
Weight	8 grams
Temperature	Commercial: 0° to +60°C Industrial: -35° to +85°C
Relative Humidity	10 to 90 %
MTBF	>100 000 Hours
Shock	50G/25ms
Vibration	20G/0-600Hz

Power Specifications

Power Input	4.25-5.25 VDC
Power Consumption	Depending on Configuration

Dimensions

(units in mm)

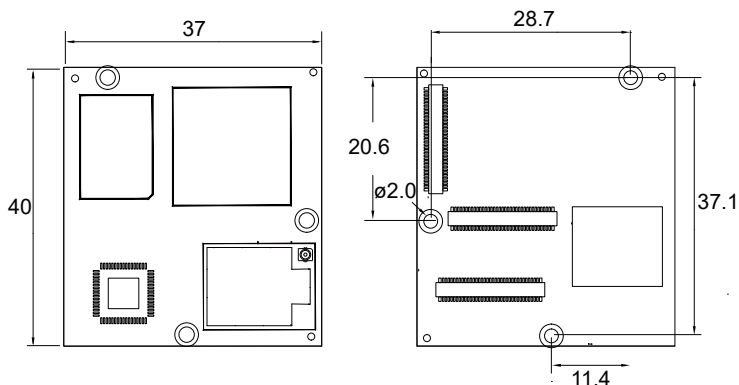

Order Information :

PICO-IMX8Mx-xx-Rxx-Exx-xxxx-xx-xxxx

	Code	Description
Processor	IMX8MQ	NXP i.MX8MQuad
Processor Speed	13	1.3GHz
	15	1.5GHz
Memory	R10	1GB LPDDR4
	R20	2GB LPDDR4
	R40	4GB LPDDR4
Storage	E16	eMMC 16GB
	EXX	eMMC other capacity
Wi-Fi / Bluetooth	-	-
	9377	Qualcomm QCA9377 802.11a/b/g/n/ac (2.4 + 5GHz) + Bluetooth
Temperature Range	-	Commercial Temperature range (0° to +60°C) (Default)
	T1	Industrial Temperature range (-40° to +85°C)
Custom ID	XXXX	Custom Part number ID for customized Software loader and special component (BOM)