



PJU4NA60 / PJD4NA60 / PJP4NA60 / PJF4NA60

600V N-Channel MOSFET

Voltage

600 V

Current

4 A

Features

- $R_{DS(ON)}, V_{GS}@10V, I_D@2A < 2.4\Omega$
- High switching speed
- Improved dv/dt capability
- Low Gate Charge
- Low reverse transfer capacitance
- Lead free in compliance with EU RoHS 2011/65/EU directive.
- Green molding compound as per IEC61249 Std.
(Halogen Free)

Mechanical Data

- Case: TO-251AA, TO-252AA, TO-220AB, ITO-220AB-F Package
- Terminals : Solderable per MIL-STD-750, Method 2026
- TO-251AA Approx. Weight : 0.0104 ounces, 0.297grams
- TO-252AA Approx. Weight : 0.0104 ounces, 0.297grams
- TO-220AB Approx. Weight : 0.067 ounces, 1.9 grams
- ITO-220AB-F Approx. Weight : 0.068 ounces, 2 grams

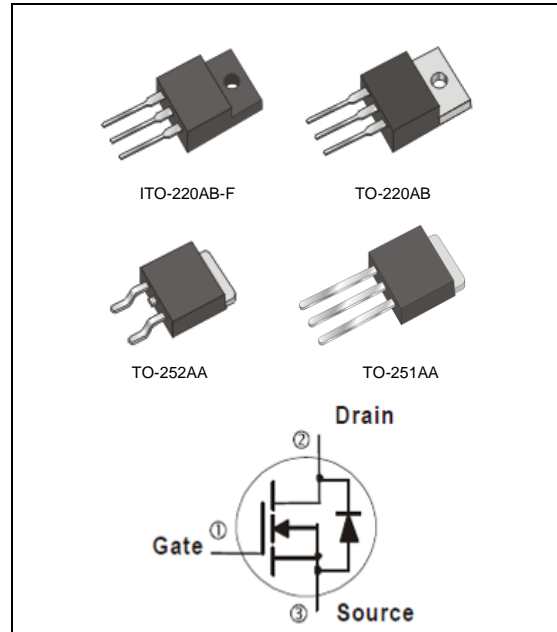

Maximum Ratings and Thermal Characteristics ($T_A=25^\circ\text{C}$ unless otherwise noted)

PARAMETER		SYMBOL	TO-251AA	TO-220AB	ITO-220AB-F	TO-252AA	UNITS
Drain-Source Voltage		V_{DS}	600				V
Gate-Source Voltage		V_{GS}	± 30				V
Continuous Drain Current		I_D	4				A
Pulsed Drain Current		I_{DM}	16				A
Single Pulse Avalanche Energy ^(Note 1)		E_{AS}	217				mJ
Power Dissipation	$T_C=25^\circ\text{C}$	P_D	77	100	33	77	W
	Derate above 25°C		0.62	0.8	0.26	0.62	W/ $^\circ\text{C}$
Operating Junction and Storage Temperature Range		T_J, T_{STG}	-55~150				$^\circ\text{C}$
Typical Thermal resistance							
- Junction to Case		$R_{\theta JC}$	1.62	1.25	3.79	1.62	$^\circ\text{C/W}$
- Junction to Ambient		$R_{\theta JA}$	110	62.5	120	110	

- Limited only By Maximum Junction Temperature



PJU4NA60 / PJD4NA60 / PJP4NA60 / PJF4NA60

Electrical Characteristics ($T_A=25^\circ\text{C}$ unless otherwise noted)

PARAMETER	SYMBOL	TEST CONDITION	MIN.	TYP.	MAX.	UNITS
Static						
Drain-Source Breakdown Voltage	BV_{DSS}	$V_{GS}=0V, I_D=250\mu A$	600	-	-	V
Gate Threshold Voltage	$V_{GS(th)}$	$V_{DS}=V_{GS}, I_D=250\mu A$	2	3.2	4	V
Drain-Source On-State Resistance	$R_{DS(on)}$	$V_{GS}=10V, I_D=2A$	-	1.92	2.4	Ω
Zero Gate Voltage Drain Current	I_{DSS}	$V_{DS}=600V, V_{GS}=0V$	-	0.03	1.0	μA
Gate-Source Leakage Current	I_{GSS}	$V_{GS}=\pm 30V, V_{DS}=0V$	-	± 10	± 100	nA
Diode Forward Voltage	V_{SD}	$I_S=4A, V_{GS}=0V$	-	0.86	1.4	V
Dynamic (Note 4)						
Total Gate Charge	Q_g	$V_{DS}=480V, I_D=4A,$ $V_{GS}=10V$ (Note 2,3)	-	11.1	-	nC
Gate-Source Charge	Q_{gs}		-	3.3	-	
Gate-Drain Charge	Q_{gd}		-	4.2	-	
Input Capacitance	C_{iss}	$V_{DS}=25V, V_{GS}=0V,$ $f=1.0\text{MHz}$	-	450	-	pF
Output Capacitance	C_{oss}		-	67	-	
Reverse Transfer Capacitance	C_{rss}		-	0.7	-	
Turn-On Delay Time	$t_{d(on)}$	$V_{DD}=300V, I_D=4A,$ $R_G=25\Omega$ (Note 2,3)	-	10	-	ns
Turn-On Rise Time	t_r		-	23	-	
Turn-Off Delay Time	$t_{d(off)}$		-	24	-	
Turn-Off Fall Time	t_f		-	24	-	
Drain-Source Diode						
Maximum Continuous Drain-Source Diode Forward Current	I_S	---	-	-	4	A
Maximum Pulsed Drain-Source Diode Forward Current	I_{SM}	---	-	-	16	A
Reverse Recovery Time	t_{rr}	$V_{GS}=0V, I_S=4A$	-	400	-	ns
Reverse Recovery Charge	Q_{rr}	$di_f/dt=100A/\mu s$ (Note 2)	-	1.7	-	μC

NOTES :

1. $L=30\text{mH}, I_{AS}=3.7A, V_{DD}=50V, R_G=25\text{ohm}$, Starting $T_J=25^\circ\text{C}$
2. Pulse width $\leq 300\mu s$, Duty cycle $\leq 2\%$
3. Essentially independent of operating temperature typical characteristics.
4. Guaranteed by design, not subject to production testing



PJU4NA60 / PJD4NA60 / PJP4NA60 / PJF4NA60

TYPICAL CHARACTERISTIC CURVES

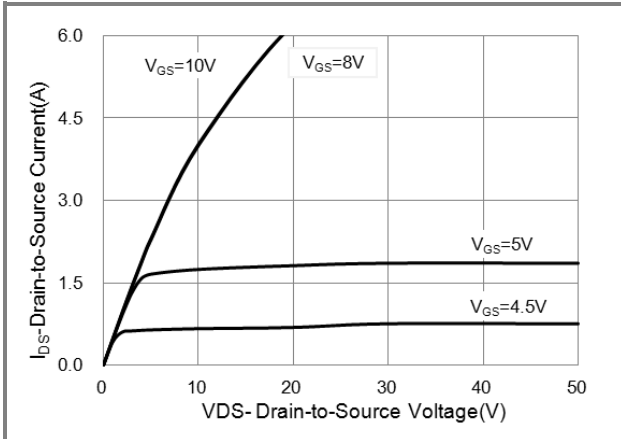

Fig.1 Output Characteristics

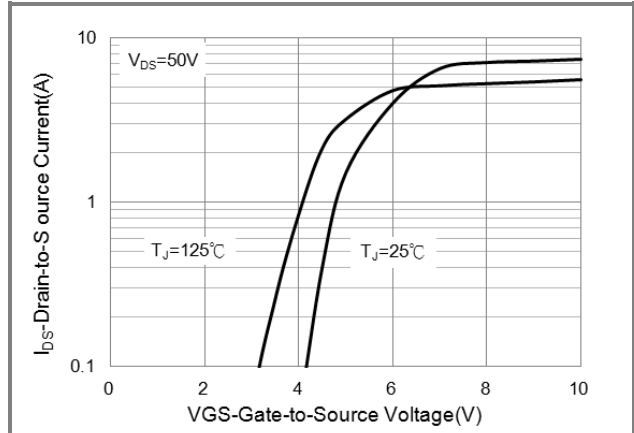

Fig.2 Transfer Characteristics

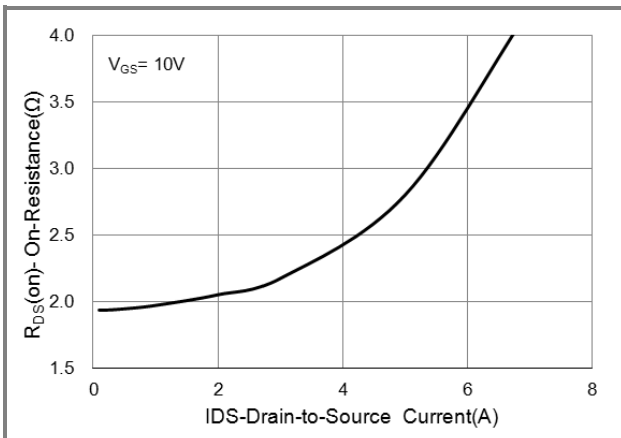

Fig.3 On-Resistance vs. Drain Current

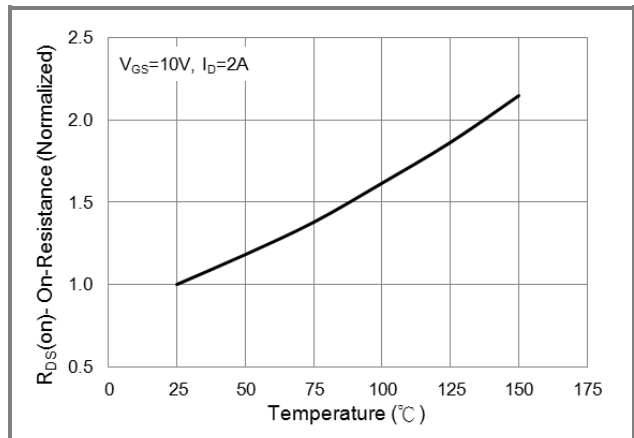

Fig.4 On-Resistance vs. Junction Temperature

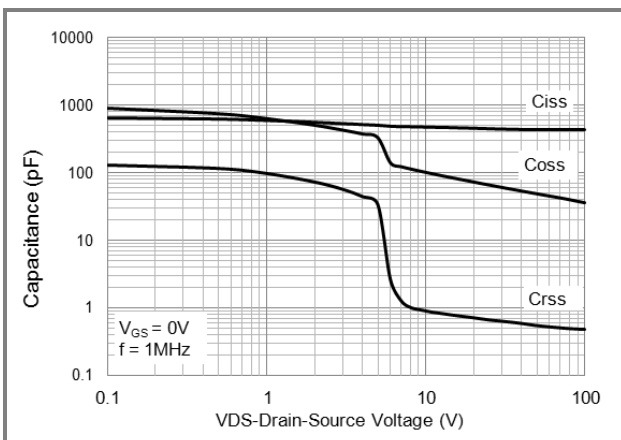

Fig.5 Capacitance vs. Drain-Source Voltage

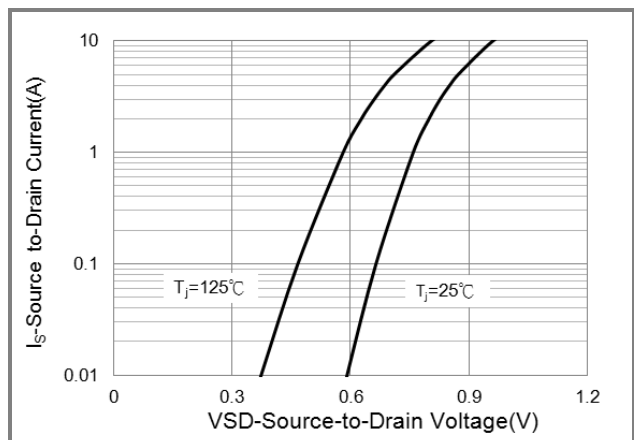
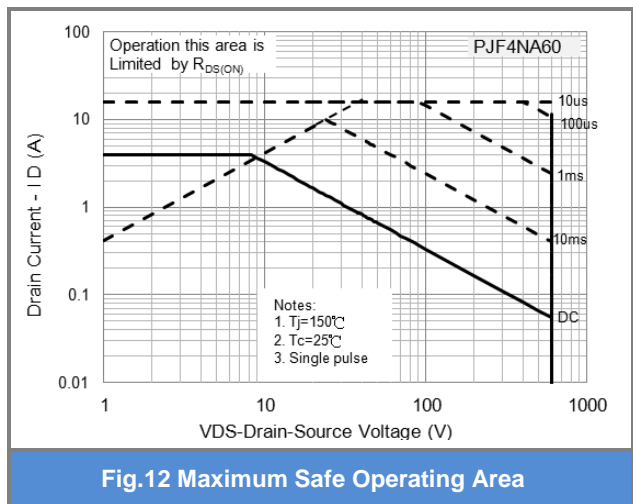
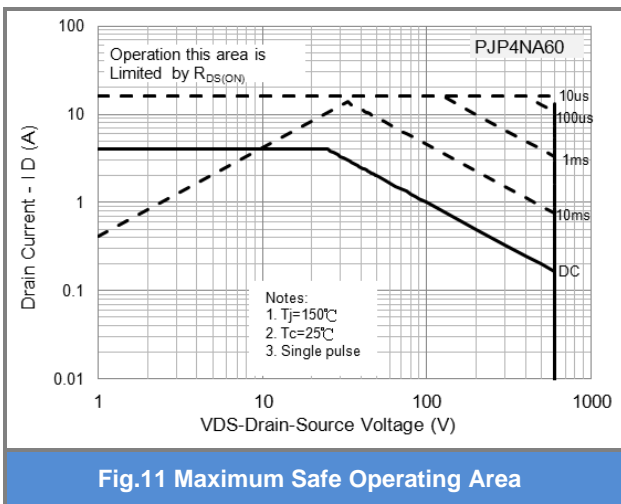
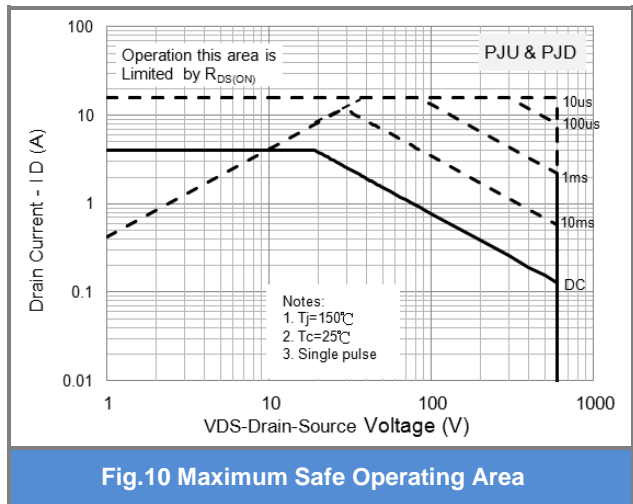
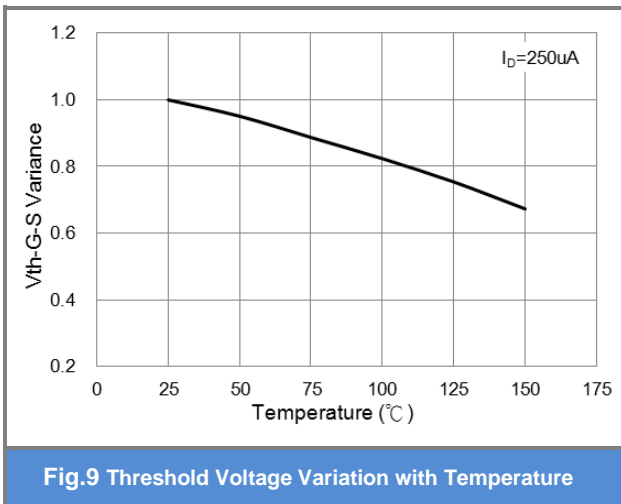
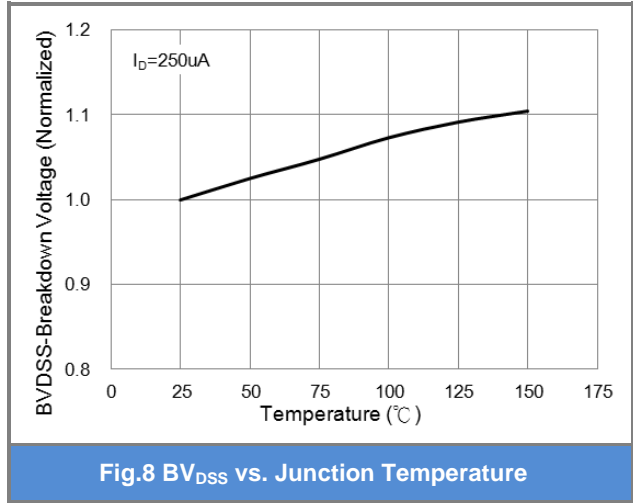
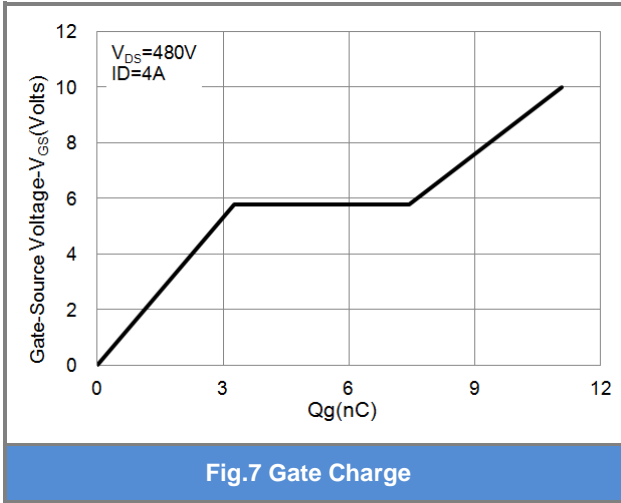

Fig.6 Source-Drain Diode Forward Voltage



PJU4NA60 / PJD4NA60 / PJP4NA60 / PJF4NA60

TYPICAL CHARACTERISTIC CURVES





PJU4NA60 / PJD4NA60 / PJP4NA60 / PJF4NA60

TYPICAL CHARACTERISTIC CURVES

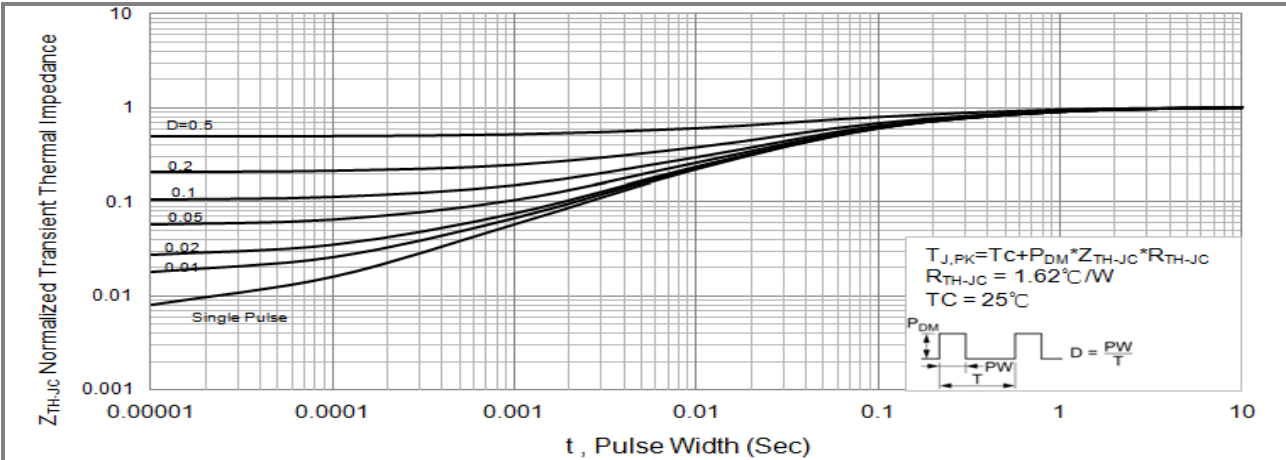

Fig.13 PJU/PJD Normalized Transient Thermal Impedance vs. Pulse Width

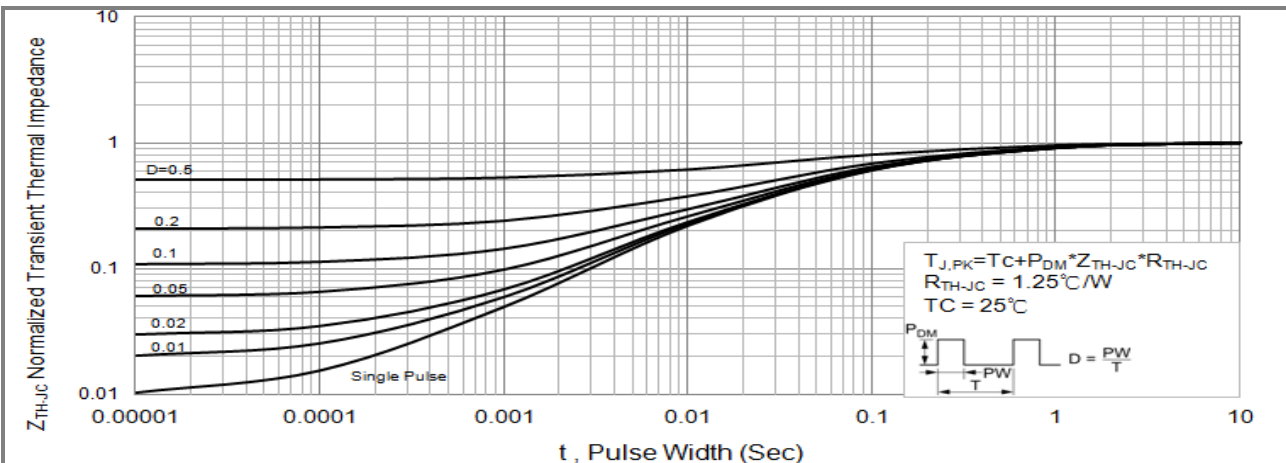

Fig.14 PJP4NA60 Normalized Transient Thermal Impedance vs. Pulse Width

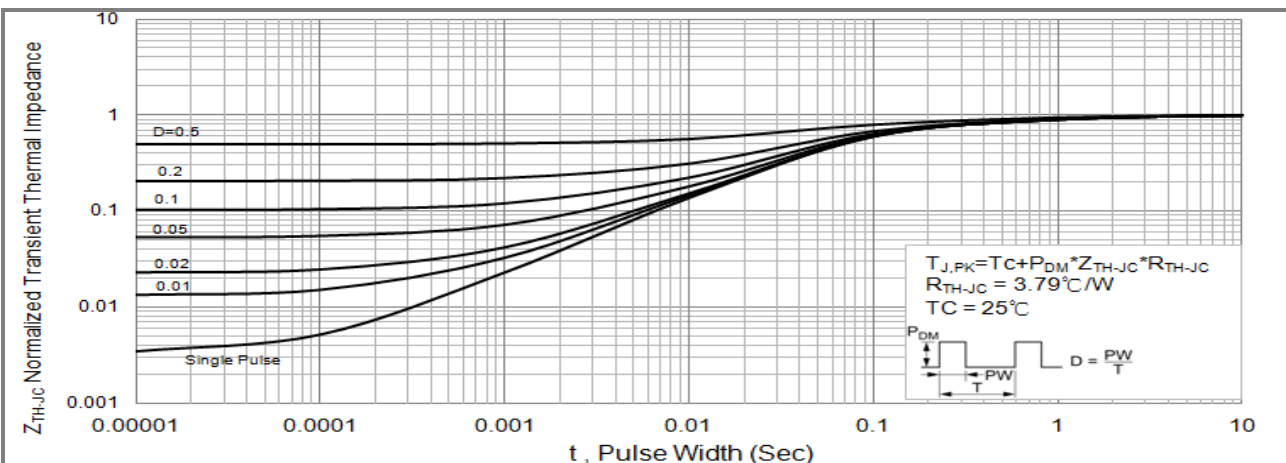
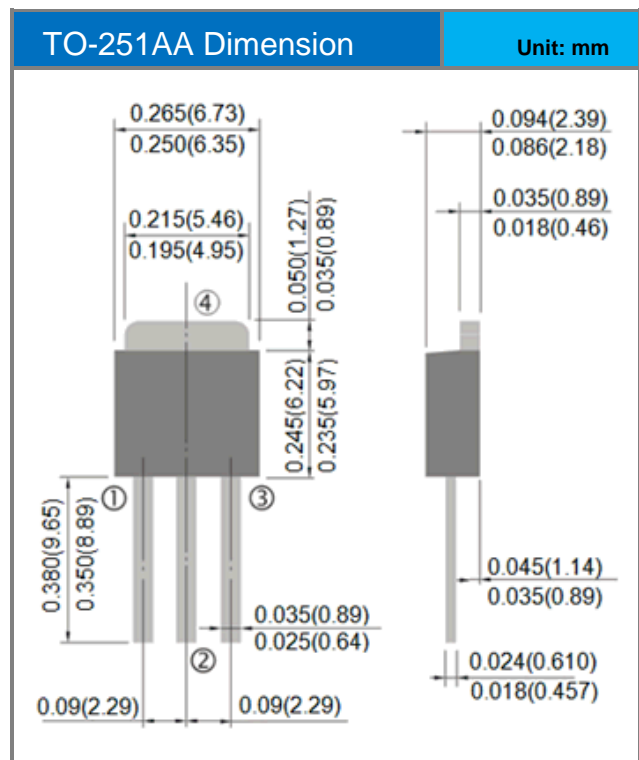
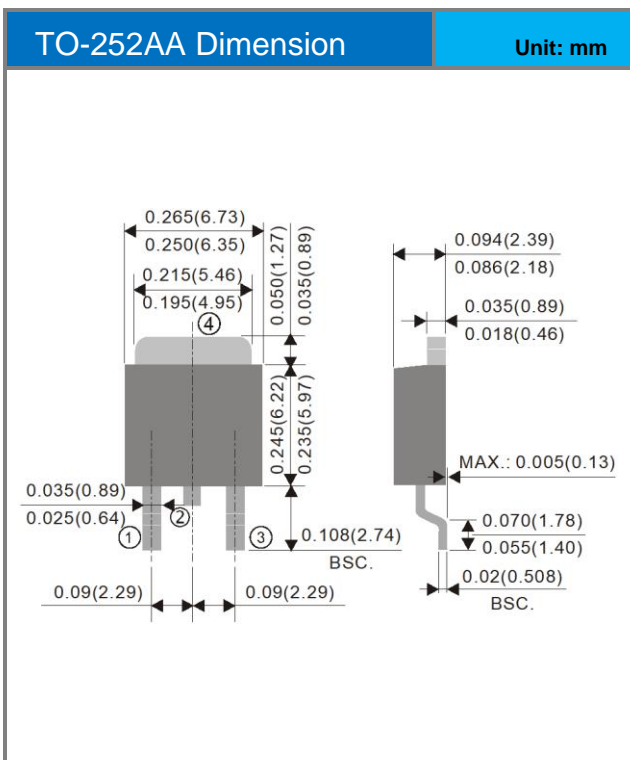
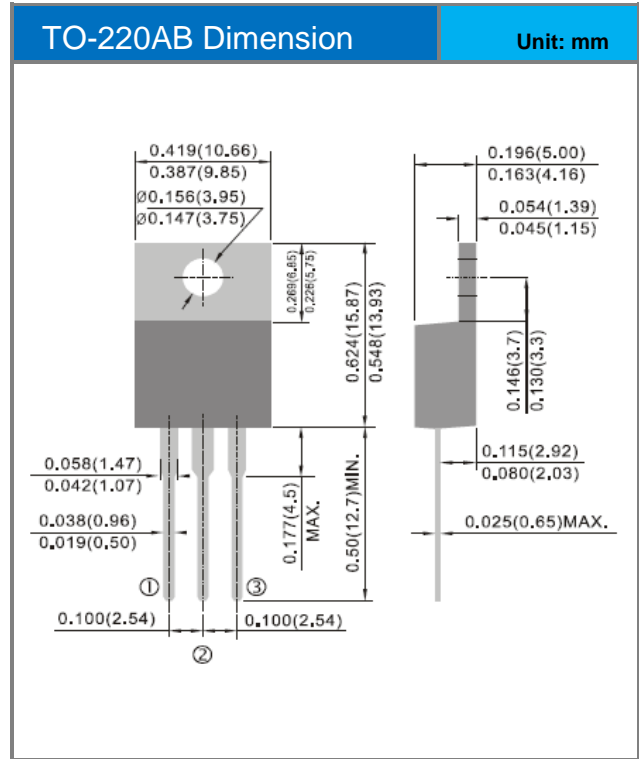
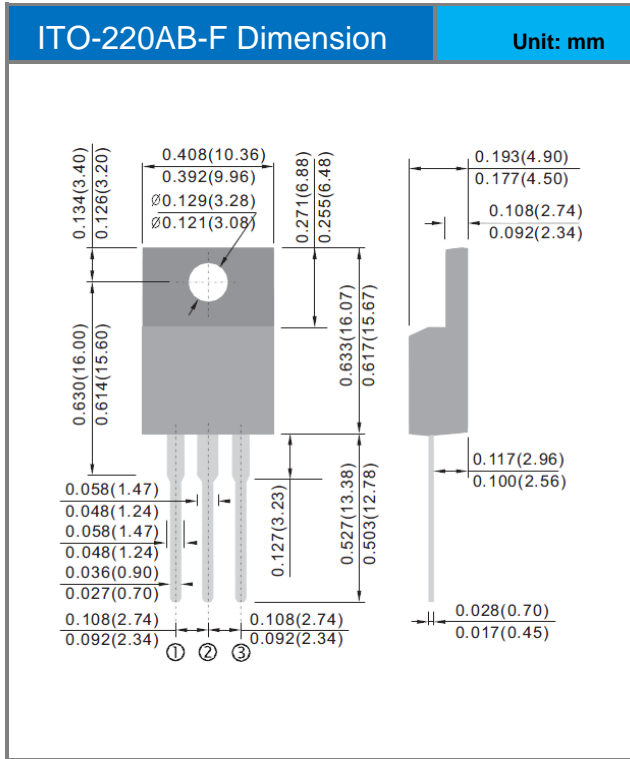

Fig.15 PJF4NA60 Normalized Transient Thermal Impedance vs. Pulse Width



PJU4NA60 / PJD4NA60 / PJP4NA60 / PJF4NA60

Packaging Information





PJU4NA60 / PJD4NA60 / PJP4NA60 / PJF4NA60

PART NO PACKING CODE VERSION

Part No Packing Code	Package Type	Packing type	Marking	Version
PJU4NA60_T0_00001	TO-251AA	80pcs / Tube	U4NA60	Halogen free
PJD4NA60_L2_00001	TO-252AA	3,000pcs / 13" reel	D4NA60	Halogen free
PJP4NA60_T0_00001	TO-220AB	50pcs / Tube	P4NA60	Halogen free
PJF4NA60_T0_00001	ITO-220AB-F	50pcs / Tube	F4NA60	Halogen free