

600V N-Channel Super Junction MOSFET

Voltage	600 V	Rdson	360 mΩ
Current	11 A	Qg	22 nC

Feature:

- $R_{DS(ON) Max, V_{GS}@10V}$: 360mΩ
- Easy to use/ drive
- High Speed Switching and Low $R_{DS(ON)}$
- 100% Avalanche Tested
- 100% Rg Tested
- Lead free in compliance with EU RoHS 2.0
- Green molding compound as per IEC 61249 standard

Mechanical Data

- Case: ITO-220AB-F package
- Terminals: Solderable per MIL-STD-750, Method 2026
- Approx. Weight: 0.068 ounces, 2 grams

Application

- PFC, TV Power, PC Power, PD Charger, Adapter, UPS

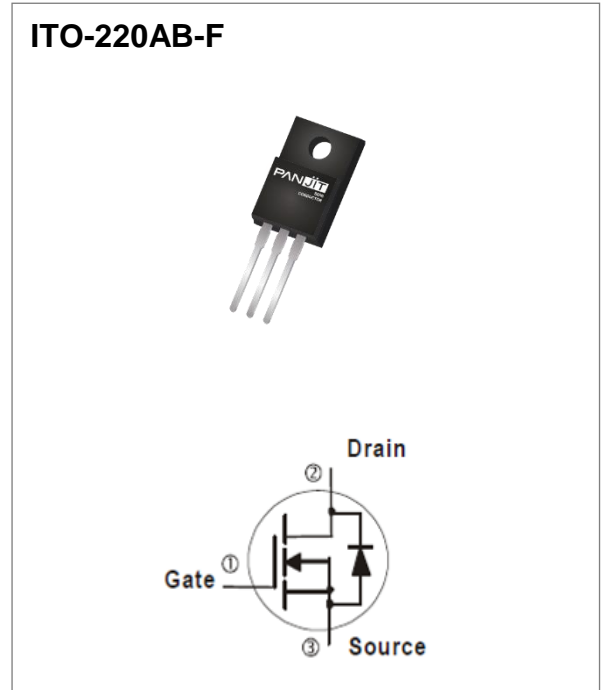

Absolute Maximum Ratings ($T_A = 25^\circ\text{C}$ unless otherwise specified)

PARAMETER		SYMBOL	LIMIT	UNITS
Drain-Source Voltage @ T_{jmax}		V_{DS}	650	V
Drain-Source Voltage		V_{DS}	600	
Gate-Source Voltage		V_{GS}	± 30	
Continuous Drain Current	$T_C=25^\circ\text{C}$	I_D	11	A
	$T_C=100^\circ\text{C}$		7	
Pulsed Drain Current	$T_C=25^\circ\text{C}$	I_{DM}	33	A
Single Pulse Avalanche Energy		E_{AS}	140	mJ
MOSFET dv/dt ruggedness		dv/dt	50	V/ns
Power Dissipation	$T_C=25^\circ\text{C}$	P_D	32	W
	$T_C=100^\circ\text{C}$		13	
Insulation Withstand Voltage for ITO-220AB-F		V_{ISO}	3.5	kV
Operating Junction and Storage Temperature Range		T_J, T_{STG}	-55~150	$^\circ\text{C}$

Thermal Characteristics

PARAMETER		SYMBOL	MAXIMUM	UNITS
Thermal Resistance	Junction-to-Case	$R_{\theta JC}$	3.9	$^\circ\text{C/W}$
	Junction-to-Ambient (Note 3)	$R_{\theta JA}$	62.5	$^\circ\text{C/W}$

Electrical Characteristics (T_A = 25 °C unless otherwise specified)

PARAMETER	SYMBOL	TEST CONDITION	MIN.	TYP.	MAX.	UNITS
Static						
Drain-Source Breakdown Voltage	BV _{DSS}	V _{GS} =0V, I _D =250uA	600	680	-	V
Gate Threshold Voltage	V _{GS(th)}	V _{DS} =V _{GS} , I _D =250uA	2	3.2	4	
Drain-Source On-State Resistance	R _{DS(on)}	V _{GS} =10V, I _D =3.8A ^(Note 1)	-	323	360	mΩ
Zero Gate Voltage Drain Current	I _{DSS}	V _{DS} =600V, V _{GS} =0V	-	-	1	uA
Gate-Source Leakage Current	I _{GSS}	V _{GS} =±30V, V _{DS} =0V	-	-	±100	nA
Transfer characteristics	gfs	V _{DS} =20V, I _D =11A	-	9	-	S
Dynamic ^(Note 5)						
Total Gate Charge	Q _g	V _{DS} =480V, I _D =11A, V _{GS} =10V	-	22	-	nC
Gate-Source Charge	Q _{gs}		-	4	-	
Gate-Drain Charge	Q _{gd}		-	10	-	
Input Capacitance	C _{iss}	V _{DS} =400V, V _{GS} =0V, f=250kHz	-	717	-	pF
Output Capacitance	C _{oss}		-	33	-	
Reverse Transfer Capacitance	C _{rss}		-	10	-	
Effective Output Capacitance Energy Related	C _{o(er)}	V _{DS} =0V to 480V, V _{GS} =0V, f=250kHz ^(Note 4)	-	42	-	
Turn-On Delay Time	t _{d(on)}	V _{DD} =300V, I _D =11A, V _{GS} =10V, R _G =25Ω ^(Note 2)	-	35	-	ns
Turn-On Rise Time	t _r		-	58	-	
Turn-Off Delay Time	t _{d(off)}		-	125	-	
Turn-Off Fall Time	t _f		-	52	-	
Gate Resistance	R _g	f=1.0MHz	-	20	-	Ω
Drain-Source Diode						
Maximum Continuous Drain-Source Diode Forward Current	I _S		-	-	11	A
Diode Forward Voltage	V _{SD}	I _S =11A, V _{GS} =0V	-	-	1.4	V
Reverse Recovery Charge	Q _{rr}	I _S =11A	-	3.9	-	μC
Reverse Recovery Time	T _{rr}	di/dt=100A/μs	-	295	-	ns

NOTES :

1. Pulse width ≤ 300us, Duty cycle ≤ 2%
2. Essentially independent of operating temperature typical characteristics.
3. R_{θJA} is the sum of the junction-to-case and case-to-ambient thermal resistance.
4. C_{o(er)} is a capacitance that gives the same stored energy as C_{oss} while V_{DS} is rising from 0V to 80% V_{(BR)DSS}
5. Guaranteed by design, not subject to production testing

TYPICAL CHARACTERISTIC CURVES

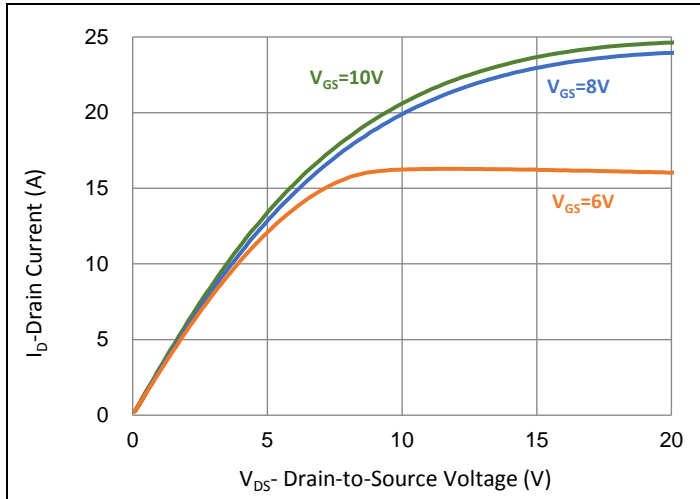

Fig.1 Output Characteristics

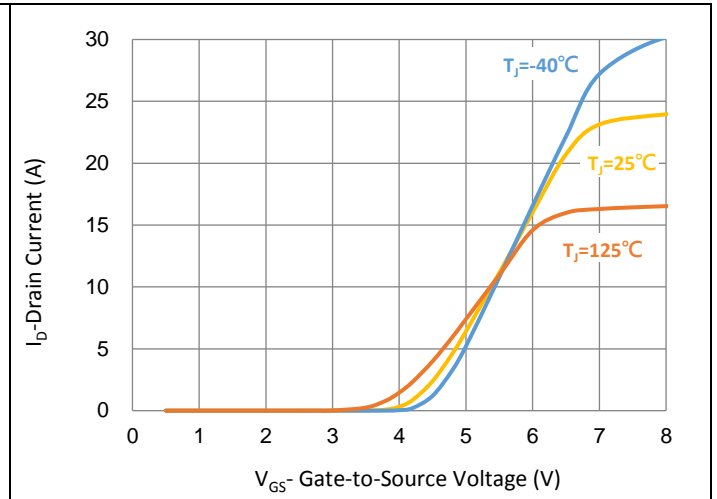

Fig.2 Transfer Characteristics

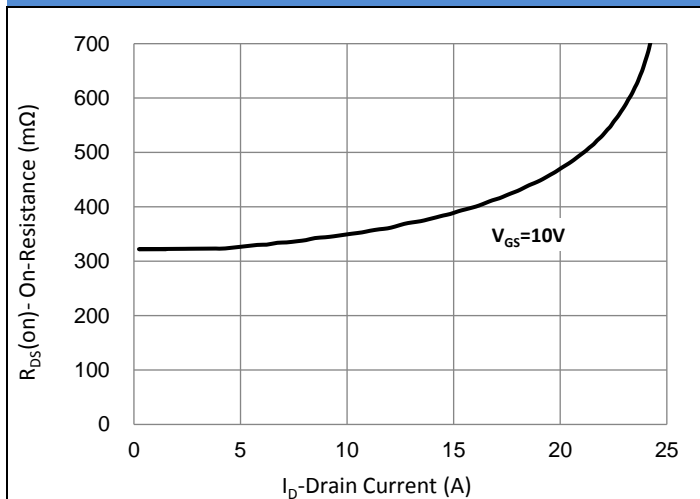

Fig.3 On-Resistance vs. Drain Current

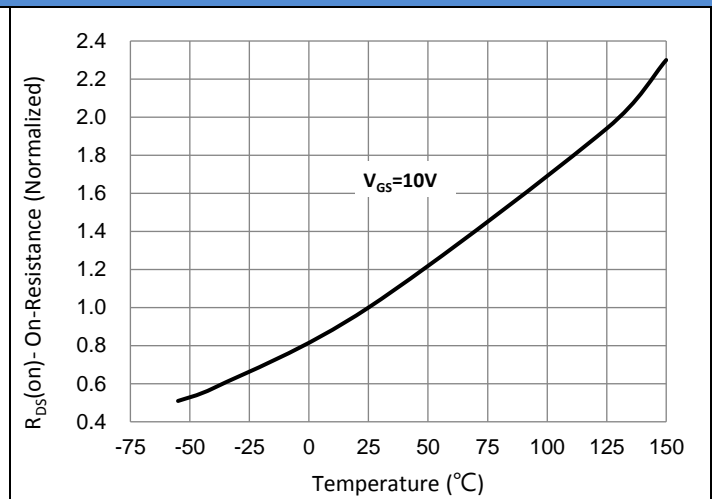

Fig.4 On-Resistance vs. Junction Temperature

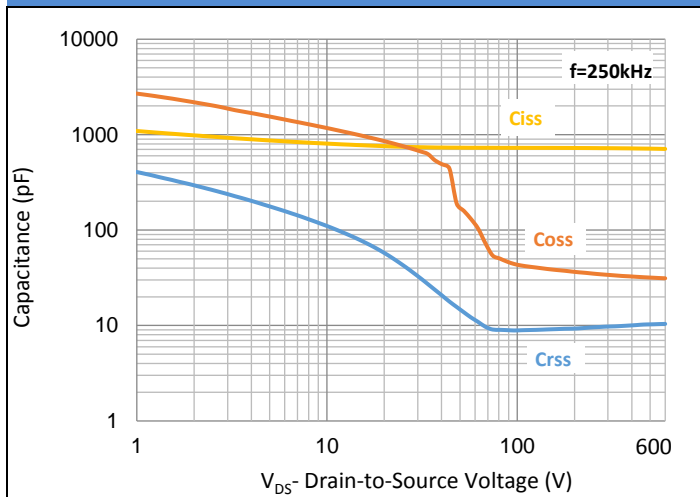

Fig.5 Capacitance vs. Drain-Source Voltage

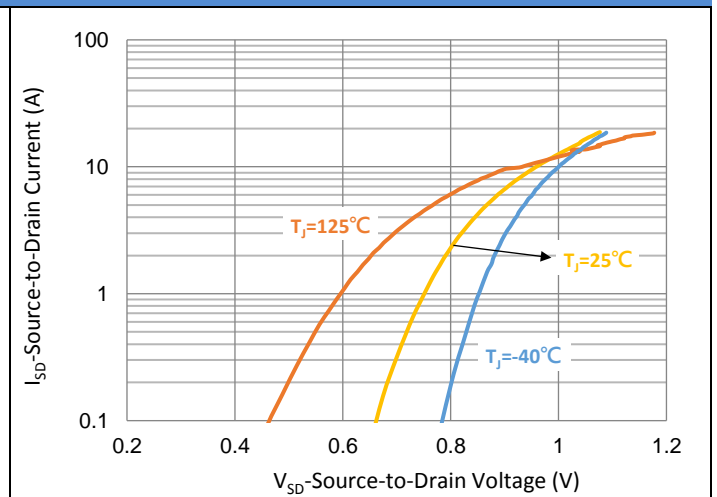

Fig.6 Source-Drain Diode Forward Voltage

TYPICAL CHARACTERISTIC CURVES

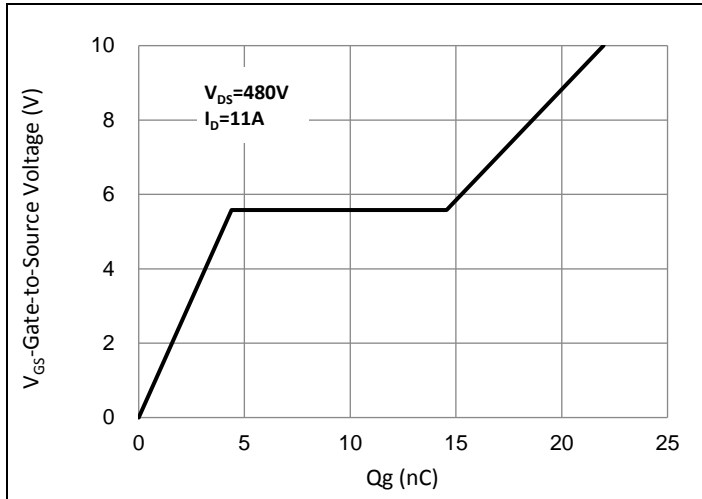

Fig.7 Gate-Charge Characteristics

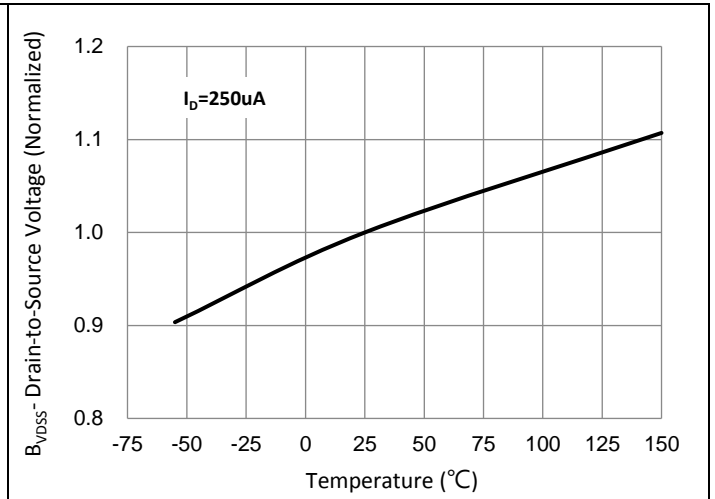

Fig.8 Breakdown Voltage Variation vs. Temperature

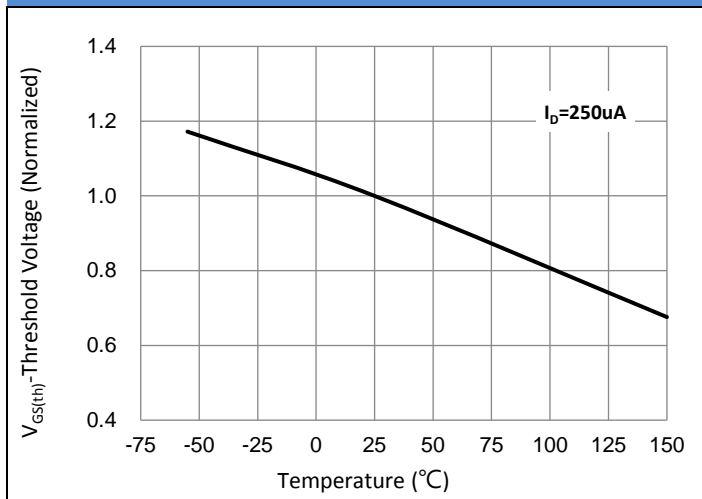

Fig.9 Threshold Voltage Variation with Temperature

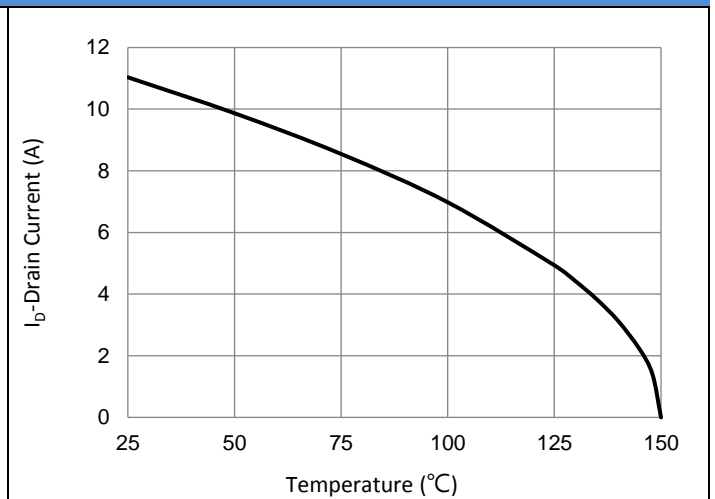

Fig.10 Drain Current vs. Case Temperature

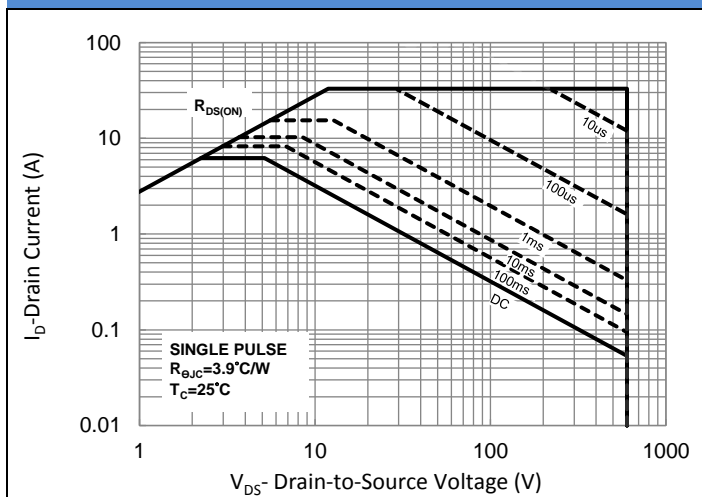

Fig.11 Maximum Safe Operating Area

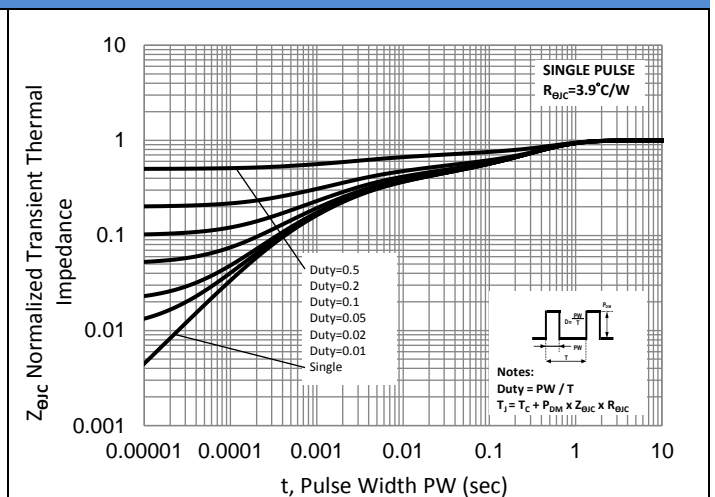

Fig.12 Normalized Transient Thermal Impedance

TYPICAL CHARACTERISTIC CURVES

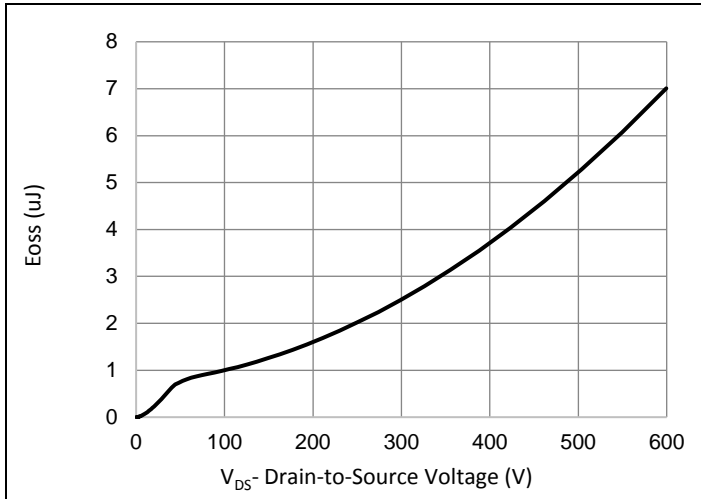
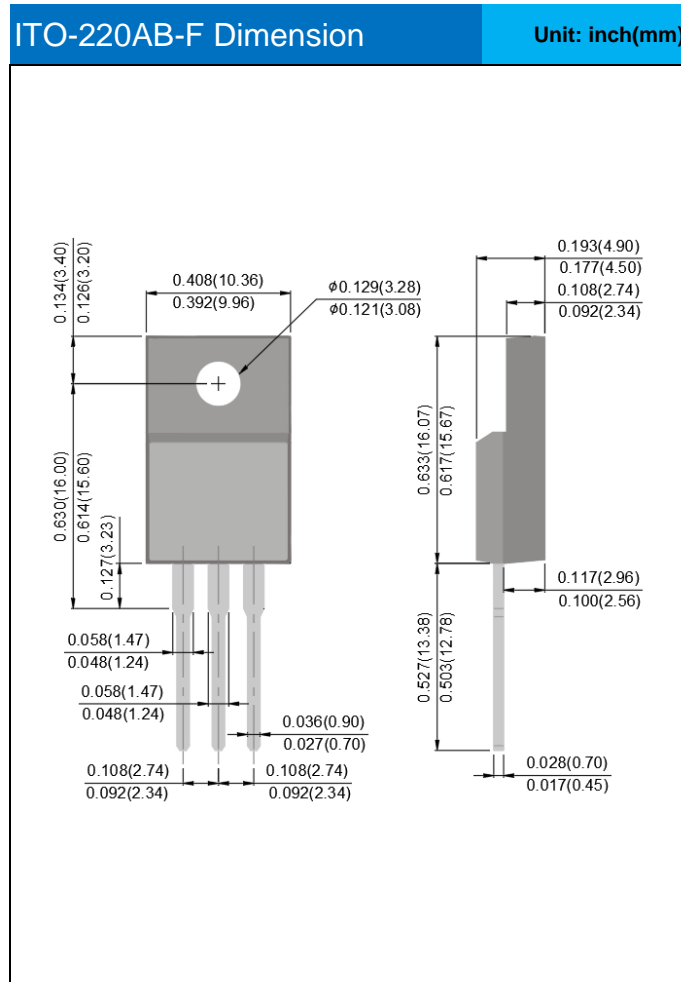

Fig.13 Typ. Coss Stored Energy

Product and Packing Information

Part No.	Package Type	Packing Type	Marking
PJMF360N60E1	ITO-220AB-F	50pcs / Tube	360N60E1

Packaging Information



Marking Diagram

PJ	Y = Year Code
360N60E1	W = Week Code (A~Z)
YWLL x	LL = Lot Code (00~99)
	x = Production Line Code