

THIS DRAWING IS UNPUBLISHED.

RELEASED FOR PUBLICATION

ALL RIGHTS RESERVED.

LOC AD DIST 0

REVISIONS

P	LTR	DESCRIPTION	DATE	DWN	APVD
D1		REVISED PER ECO-11-004917	11MAR11	RK	HMR

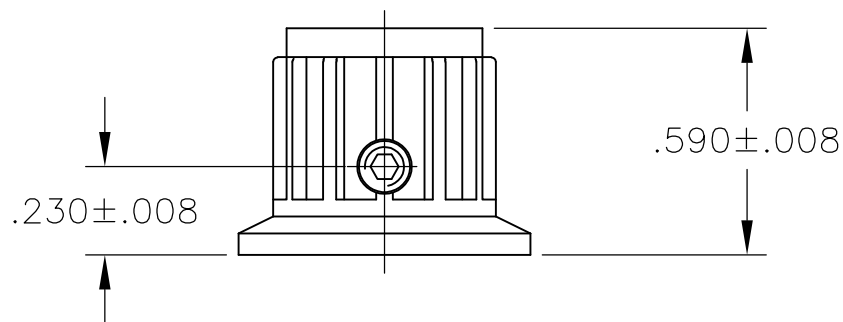
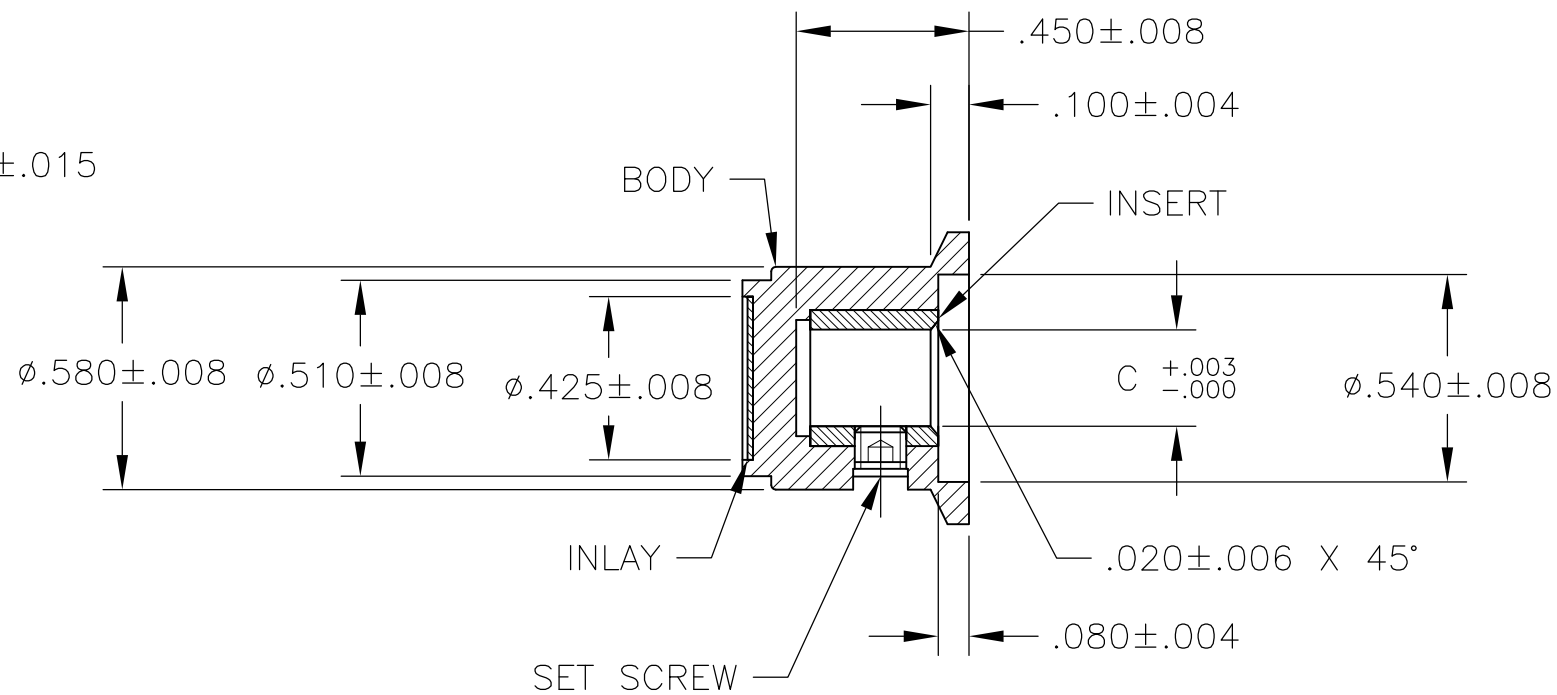
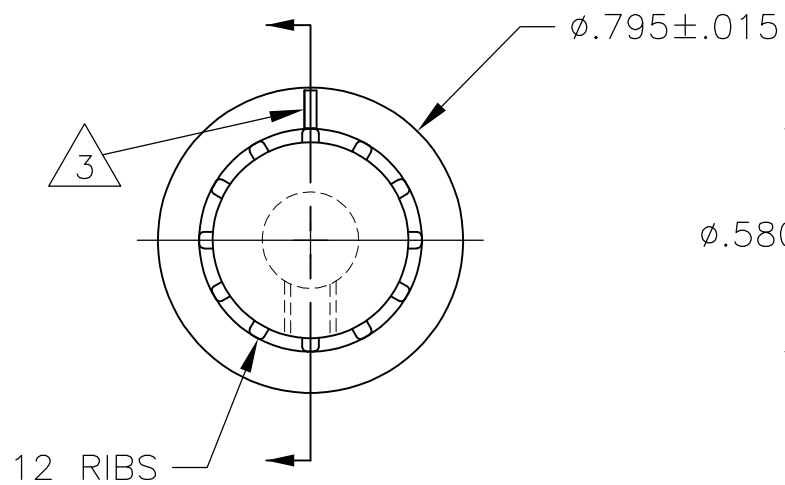

- MATERIAL AND FINISH:
 SKIRT AND INLAY: ALUMINUM .016 THK., CLEAR ACRYLIC COATED
 BODY: PHENOLIC, BLACK, HIGH GLOSS FINISH (SPE/SP1#A2)
 SET SCREW: 303 STAINLESS STEEL, BLACK ANODIZED
 INSERT: BRASS

- SET SCREW ARE UNC-2A, CUP POINT, HEX SOCKET TYPE.
- INDICATOR, PAINTED FULL, COLOR: WHITE; .02 ± 0.01 DEEP
- RETENTION FORCE OF INSERT IN KNOB BODY: 2 LBS MIN.

#6-32 X .188	.126	PKA50B1/8	1-1437624-1
#6-32 X .125	.251	PKA50B1/4	1-1437624-0
SET SCREW	C	MODEL NUMBER	PART NUMBER
	SHAFT HOLE		

THIS DRAWING IS A CONTROLLED DOCUMENT.		DWN M.BINNER	25MAR03	STE TE Connectivity													
DIMENSIONS: INCHES		CHK -	APVD -			PKA KNOB SERIES STANDARD											
TOLERANCES UNLESS OTHERWISE SPECIFIED:		PRODUCT SPEC -	APPLICATION SPEC -	NAME -													
<table border="0"> <tr><td>0 PLC</td><td>± -</td></tr> <tr><td>1 PLC</td><td>± -</td></tr> <tr><td>2 PLC</td><td>± -</td></tr> <tr><td>3 PLC</td><td>± -</td></tr> <tr><td>4 PLC</td><td>± -</td></tr> <tr><td>ANGLES</td><td>± -</td></tr> </table>		0 PLC	± -	1 PLC	± -	2 PLC	± -	3 PLC	± -	4 PLC	± -	ANGLES	± -	WEIGHT -	SIZE A3	CAGE CODE 00779	DRAWING NO C-1-1437624-0
0 PLC	± -																
1 PLC	± -																
2 PLC	± -																
3 PLC	± -																
4 PLC	± -																
ANGLES	± -																
MATERIAL -		CUSTOMER DRAWING		RESTRICTED TO -	SCALE 2:1												
FINISH -		SHEET 1 OF 4		REV D1													

THIS DRAWING IS UNPUBLISHED. RELEASED FOR PUBLICATION
 © COPYRIGHT - By - ALL RIGHTS RESERVED.

LOC	DIST	REVISIONS					
AD	0	P	LTR	DESCRIPTION	DATE	DWN	APVD
		-		SEE SHEET 1	-	-	-

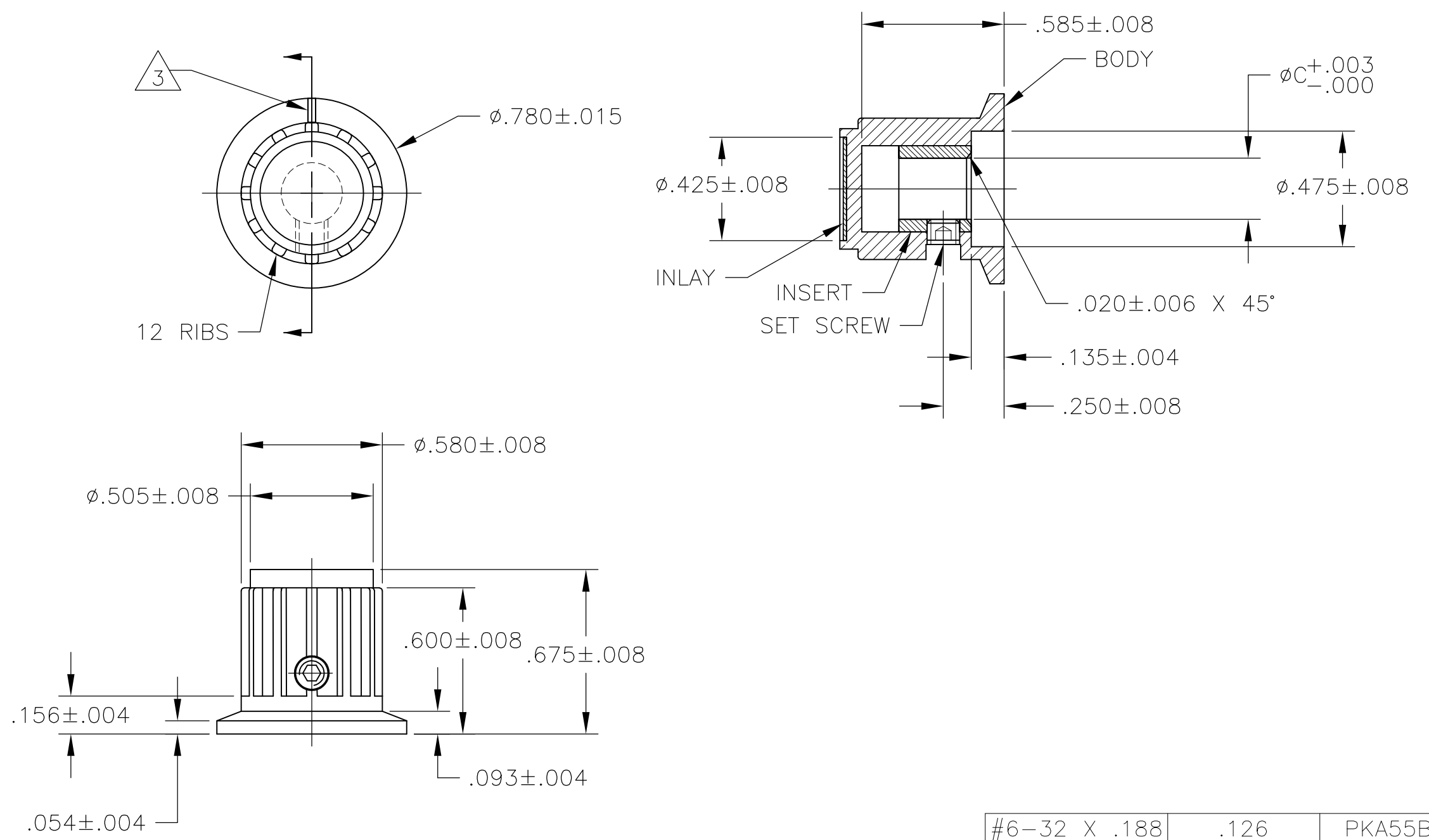

#6-32 X .188	.126	PKA55B1/8	1-1437624-4
#6-32 X .125	.251	PKA55B1/4	1-1437624-3
SET SCREW	C	MODEL NUMBER	PART NUMBER
2	SHAFT HOLE		

THIS DRAWING IS A CONTROLLED DOCUMENT.		DWN	M.BINNER	25MAR03	STE TE Connectivity		
DIMENSIONS: INCHES		CHK	-	-			
TOLERANCES UNLESS OTHERWISE SPECIFIED:		APVD	-	-	NAME		
0 PLC ± -		PRODUCT SPEC	-	-	SIZE		
1 PLC ± -		APPLICATION SPEC	-	-	CAGE CODE	DRAWING NO	RESTRICTED TO
2 PLC ± -			-	-	A3	00779	C-1-1437624-0
3 PLC ± -			-	-	SCALE		
4 PLC ± -			-	-	1:1		
ANGLES ± -		WEIGHT	-	-	SHEET		
FINISH			-	-	2 OF 4		
MATERIAL			-	-	REV		
			-	-	D1		
CUSTOMER DRAWING							

THIS DRAWING IS UNPUBLISHED.

RELEASED FOR PUBLICATION

ALL RIGHTS RESERVED.

© COPYRIGHT - By -

LOC AD DIST 0

REVISIONS

P	LTR	DESCRIPTION	DATE	DWN	APVD
-	-	SEE SHEET 1	-	-	-

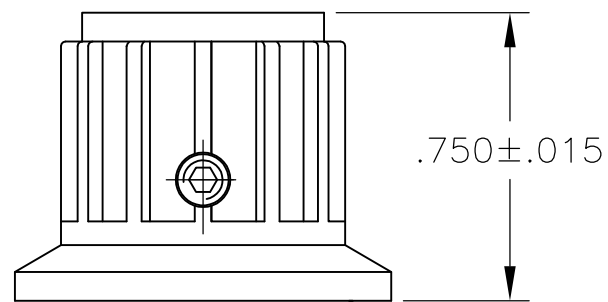
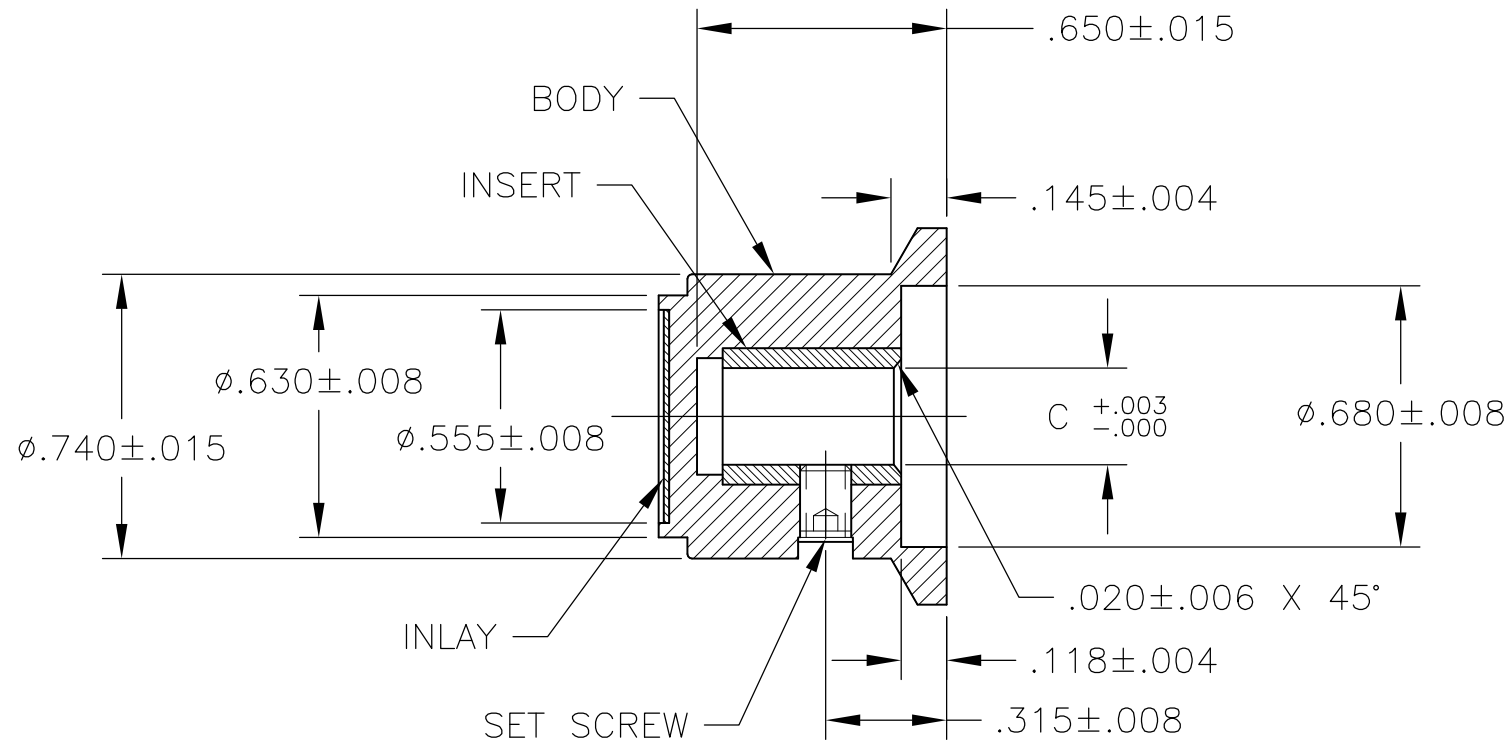
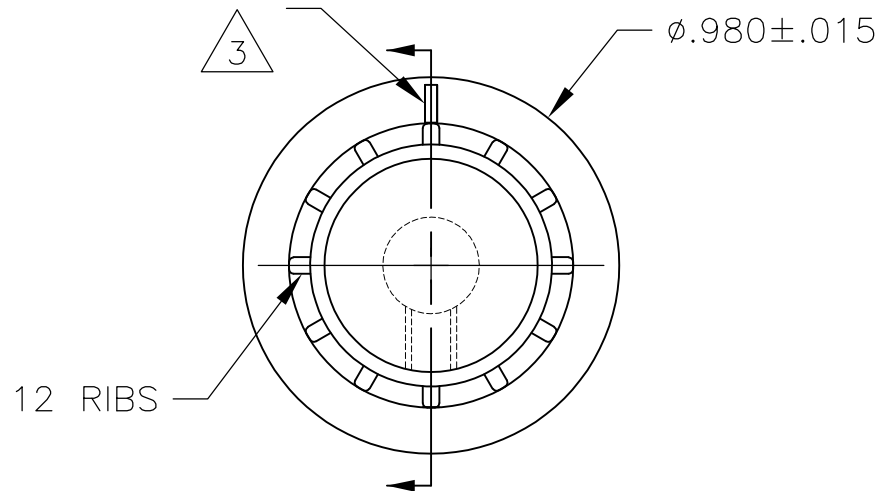

#6-32 X .188	.251	PKA70B1/4	1-1437624-5
SET SCREW	C SHAFT HOLE	MODEL NUMBER	PART NUMBER

THIS DRAWING IS A CONTROLLED DOCUMENT.		DWN M.BINNER	25MAR03	STE TE Connectivity													
DIMENSIONS: INCHES		CHK -	APVD -			NAME											
TOLERANCES UNLESS OTHERWISE SPECIFIED:		PRODUCT SPEC		PKA KNOB SERIES STANDARD													
<table border="0"> <tr><td>0 PLC</td><td>± -</td></tr> <tr><td>1 PLC</td><td>± -</td></tr> <tr><td>2 PLC</td><td>± -</td></tr> <tr><td>3 PLC</td><td>± -</td></tr> <tr><td>4 PLC</td><td>± -</td></tr> <tr><td>ANGLES</td><td>± -</td></tr> </table>		0 PLC	± -	1 PLC	± -	2 PLC	± -	3 PLC	± -	4 PLC	± -	ANGLES	± -	APPLICATION SPEC		RESTRICTED TO	
0 PLC	± -																
1 PLC	± -																
2 PLC	± -																
3 PLC	± -																
4 PLC	± -																
ANGLES	± -																
MATERIAL -		WEIGHT -		SIZE A3	CAGE CODE 00779												
FINISH -		CUSTOMER DRAWING		DRAWING NO C-1-1437624-0	RESTRICTED TO -												
		SCALE 1:1		SHEET 3 OF 4	REV D1												