

THIS DRAWING IS UNPUBLISHED. RELEASED FOR PUBLICATION
 © COPYRIGHT - By - ALL RIGHTS RESERVED.

LOC	DIST	REVISIONS					
AD	00	P	LTR	DESCRIPTION	DATE	DWN	APVD
		F		REVISED PER ECO-14-003814	12JUN2014	NK	RH

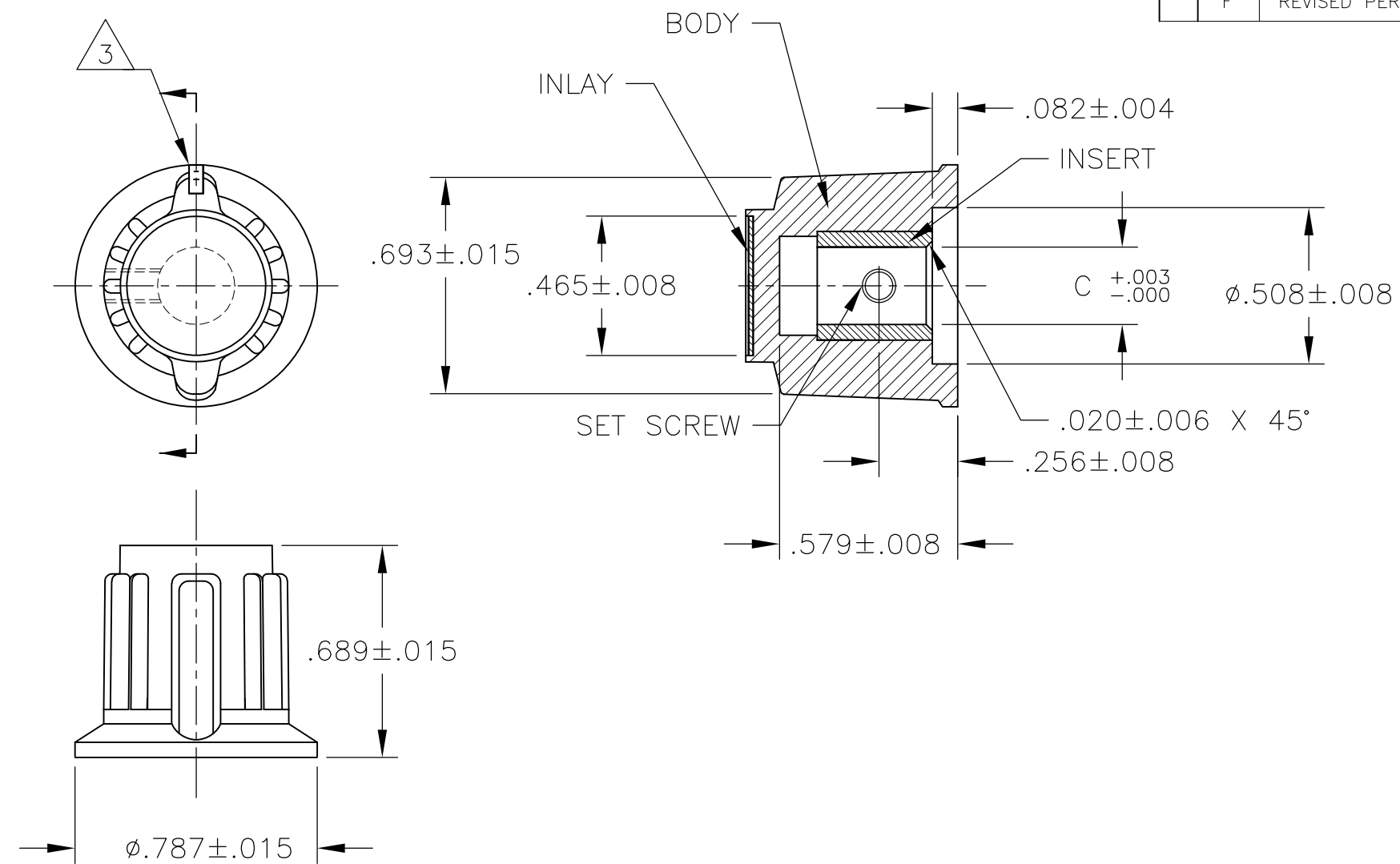

- 1 MATERIAL AND FINISH:
 INLAY: ALUMINUM .016 THK., CLEAR ACYLIC COATED
 BODY: PHENOLIC, BLACK, HIGH GLOSS FINISH (SPE/SPI#A2)
 SET SCREW: 303 STAINLESS STEEL, BLACK ANODIZED
 INSERT: BRASS

- 2 SET SCREW ARE UNC-2A, CUP POINT, HEX SOCKET TYPE.
 3 INDICATOR, PAINTED FULL, COLOR: WHITE; .030±.010 DEEP
 4 RETENTION FORCE OF INSERT IN KNOB BODY: 50 LBS MIN.

OBSOLETE	#6-32 X .125	.126	PKAP50B1/8	1-1437624-9
	#6-32 X .125	.251	PKAP50B1/4	1-1437624-8
	2 SET SCREW	C SHAFT HOLE	MODEL NUMBER	PART NUMBER

THIS DRAWING IS A CONTROLLED DOCUMENT.		DWN	M.BINNER	25MAR03	STE TE Connectivity		
DIMENSIONS: INCHES		CHK	-	-			
TOLERANCES UNLESS OTHERWISE SPECIFIED:		APVD	-	-	NAME		
0 PLC ± -		PRODUCT SPEC	-	-	SIZE		
1 PLC ± -		APPLICATION SPEC	-	-	CAGE CODE	DRAWING NO	RESTRICTED TO
2 PLC ± -			-	-	A3	00779	C-1-1437624-8
3 PLC ± -			-	-	SCALE		
4 PLC ± -			-	-	2:1		
ANGLES ± 2'			-	-	SHEET		
MATERIAL -		FINISH -		-	1 OF 3		
					REV		
					F		

THIS DRAWING IS UNPUBLISHED. RELEASED FOR PUBLICATION
 © COPYRIGHT - By - ALL RIGHTS RESERVED.

LOC	DIST	REVISIONS					
AD	00	P	LTR	DESCRIPTION	DATE	DWN	APVD
		-		SEE SHEET 1	-	-	-

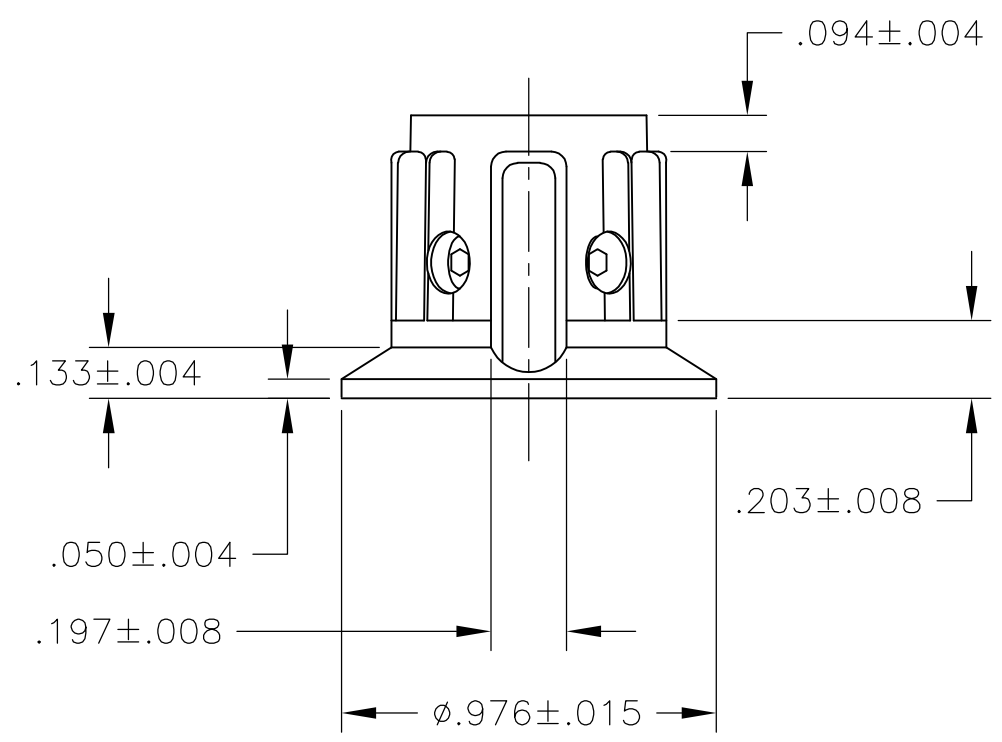
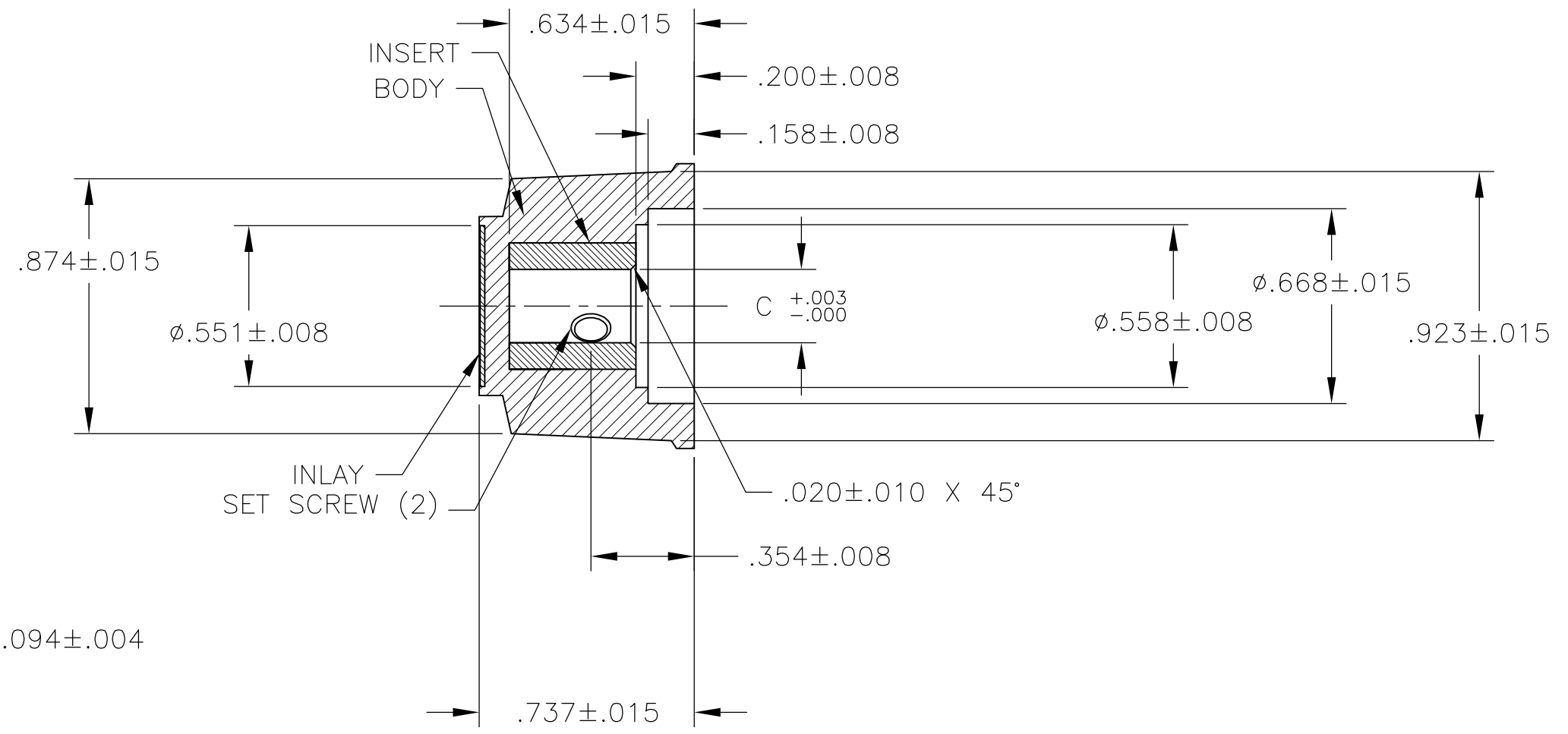
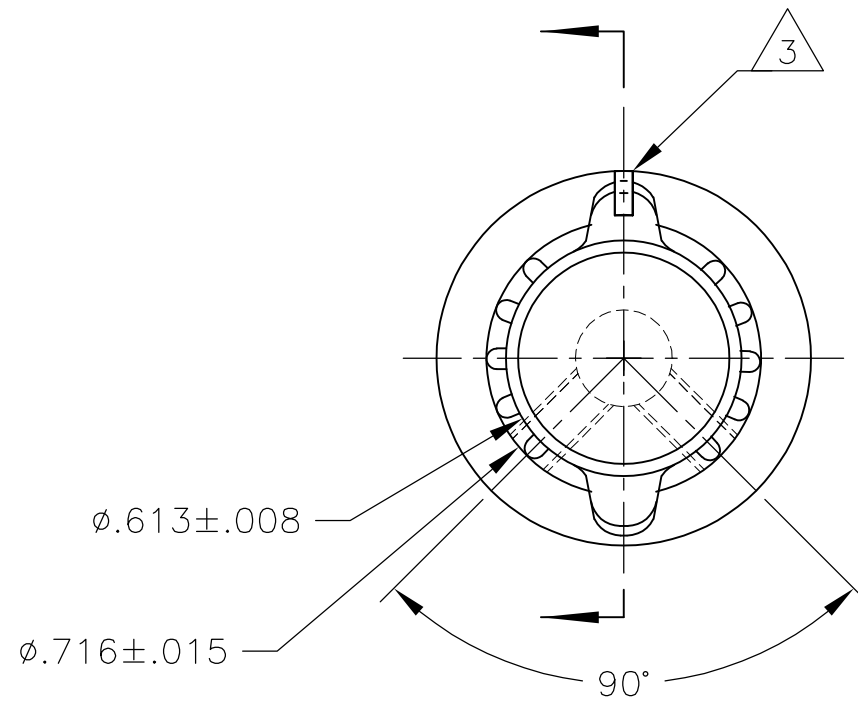

#6-32 X .188	.251	PKAP70B1/4	2-1437624-0
$\triangle 2$ SET SCREW	C SHAFT HOLE	MODEL NUMBER	PART NUMBER

THIS DRAWING IS A CONTROLLED DOCUMENT.		DWN M.BINNER	25MAR03	STE TE Connectivity													
DIMENSIONS: INCHES		CHK -	APVD -			NAME											
TOLERANCES UNLESS OTHERWISE SPECIFIED:		PRODUCT SPEC -		PKA KNOB SERIES STANDARD													
<table border="0"> <tr><td>0 PLC</td><td>± -</td></tr> <tr><td>1 PLC</td><td>± -</td></tr> <tr><td>2 PLC</td><td>± -</td></tr> <tr><td>3 PLC</td><td>± -</td></tr> <tr><td>4 PLC</td><td>± -</td></tr> <tr><td>ANGLES</td><td>± 2'</td></tr> </table>		0 PLC	± -	1 PLC	± -	2 PLC	± -	3 PLC	± -	4 PLC	± -	ANGLES	± 2'	APPLICATION SPEC -		SIZE	RESTRICTED TO
0 PLC	± -																
1 PLC	± -																
2 PLC	± -																
3 PLC	± -																
4 PLC	± -																
ANGLES	± 2'																
MATERIAL -		WEIGHT -		CAGE CODE A300779	DRAWING NO C-1-1437624-8												
CUSTOMER DRAWING				SCALE 1:1	SHEET 2 OF 3												
				REV F													