

HIGH FREQUENCY PLANAR TRANSFORMERS



Ruggedized

NJ / . / VV Qcpgcq

- ⊗ Fcgefr8 5,2kk K_v
- ⊗ Dmmrnpgl r8 /7,6kk v /7,4kk K_v
- ⊗ AsppcIr P_rgl e8 sn rm 51?
- ⊗ Glbsar_lac P_l ec8 ,2.3ØF rm 4,0ØF
- ⊗ Kmqrspc Qc l qgrtgrw Jctcjb /

Electrical Specifications @ 25 °C – Operating Temperature – 40°C to +130 °C

Part Number ^{5,7}	Inductance @ Irated (µH ±15%)	Irated ¹ (A _{DC})	DCR (mΩ)		Inductance @ 0 A _{DC} (µH ±15%)	Saturation Current ²		Heating Current ³ (A)
			TYP	MAX		25°C	100°C	
2-TURN (LOW - LOSS) SERIES								
PL10100	0.45	73	.38	.48	0.45	95	80	73
PL10101	0.63	54	.38	.48	0.65	63	53	73
PL10102	0.85	39	.38	.48	0.91	46	37	73
PL10103	1.05	30	.38	.48	1.10	35	30	73
PL10104	1.25	25	.38	.48	1.30	29	26	73
PL10105	1.45	21	.38	.48	1.50	24	22	73
2-TURN SERIES								
PL10106	0.45	52	.78	.98	0.45	95	80	52
PL10107	0.63	52	.78	.98	0.65	63	53	52
PL10108	0.85	39	.78	.98	0.91	46	37	52
PL10109	1.05	30	.78	.98	1.10	35	30	52
PL10110	1.25	25	.78	.98	1.30	29	26	52
PL10111	1.45	21	.78	.98	1.50	24	22	52
3-TURN SERIES								
PL10112	0.95	42	1.15	1.43	1.0	68	54	42
PL10113	1.40	36	1.15	1.43	1.5	43	35	42
PL10114	1.90	25	1.15	1.43	2.0	29	25	42
PL10115	2.40	20	1.15	1.43	2.5	23	21	42
PL10116	2.80	15	1.15	1.43	3.0	18	16	42
PL10117	3.40	12	1.15	1.43	3.5	15	13	42
4-TURN SERIES								
PL10118	1.60	37	1.44	1.80	1.60	55	43	37
PL10119	2.40	30	1.44	1.80	2.42	35	27	37
PL10120	3.30	17	1.44	1.80	3.60	20	18	37
PL10121	4.00	14	1.44	1.80	4.40	16	15	37
PL10122	4.90	11	1.44	1.80	5.34	13	12	37
PL10123	5.80	9	1.44	1.80	6.20	11	10	37

- NOTES:
- Parts can be ordered Non-Lead by adding "NL" to the part number (i.e. **PL10303NL**)
 - Optional Tape & Reel packaging can be ordered by adding a "T" suffix at the end of the part number (i.e. **PL10301T**)
 - The rated current as listed is either 85% of the saturation current or the heating current, depending on which value is lower.
 - The saturation current is the current which causes the inductance to drop by 15% at the stated ambient temperatures (25°C and 100°C). This current is determined by placing the component in the specified ambient environment and applying a short duration pulse current (to eliminate self-heating effects) to the component.
 - The heating current is the DC current which causes the temperature of the part to increase by approximately 45°C. This current is determined by mounting the component on a PCB with .25" wide, 2 oz. equivalent copper traces, and applying the current to the device for 30 minutes with no forced air cooling.
 - In high volt*time applications, additional heating in the component can occur due to core losses in the inductor which may necessitate derating the current in order to limit the temperature rise of the component. In order to determine the approximate total losses (or temperature rise) for a given application, the total copper and core losses should be taken into account. For approximate value of core losses, in a given application, use the core loss graph on page 24.
 - Meets solderability test per IPC/EIA J-STD-002B using flux type ORLO.



HIGH FREQUENCY PLANAR TRANSFORMERS

Ruggedized



Mechanical

PL101XX

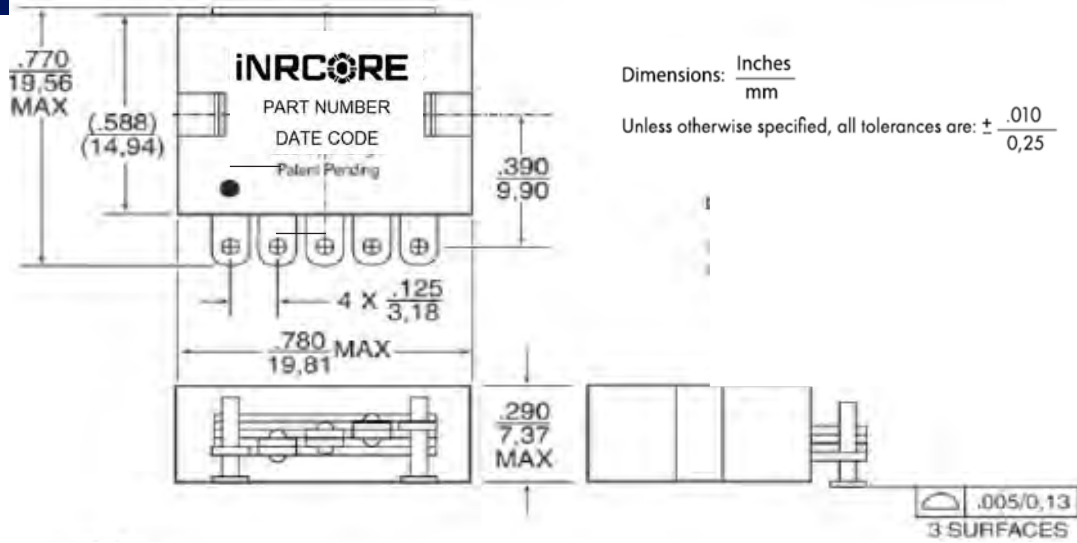

Suggested Pad Layouts and Schematics

PL101XX

PL10100 - PL10111
 .405 to 1.50 μH
 21 to 73 Adc

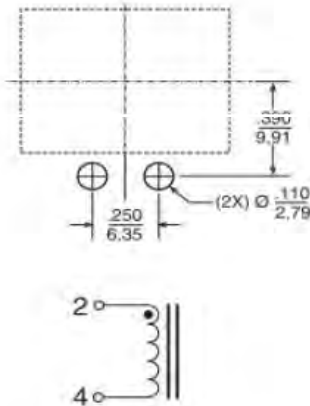

PL10112 - PL10117
 1.00 to 3.40 μH
 12 to 42 Adc

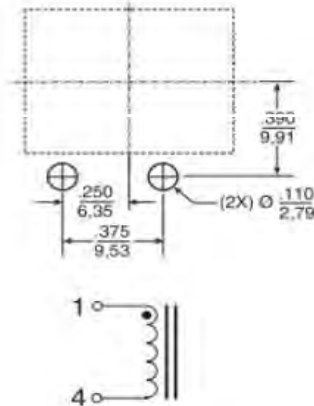

PL10118 - PL10123
 1.60 to 6.20 μH
 9 to 37 Adc

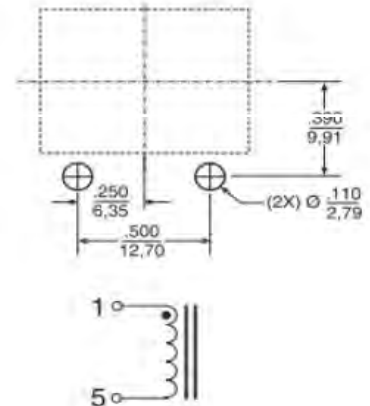

Ruggedized

Inductance vs. Current Characteristics (25°C)

PL101XX

PL10100 - PL10111

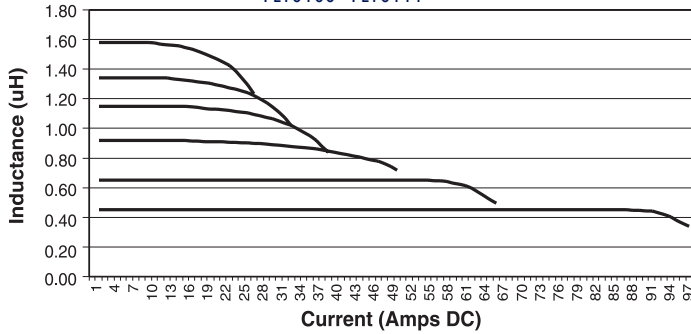

PL10112 - PL10117

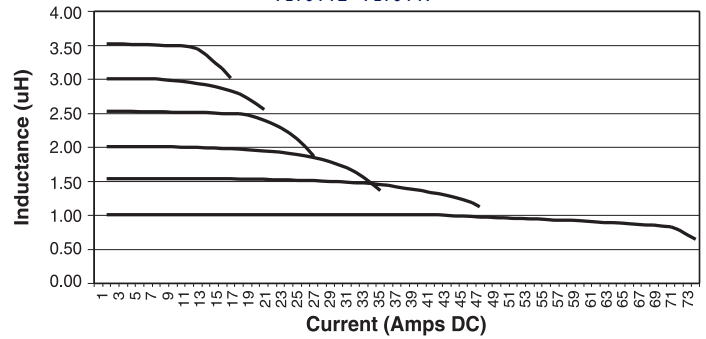

PL10118 - PL10123

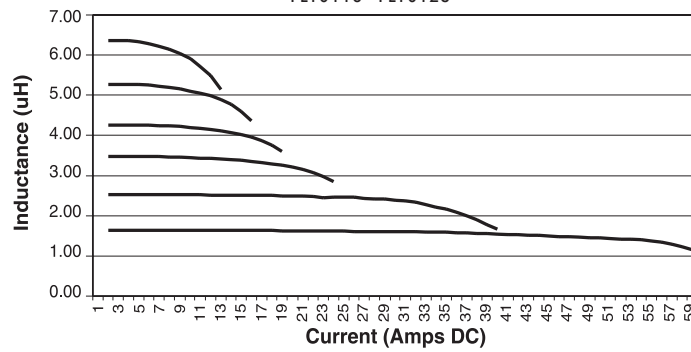

Measurements Charts

PL101XX

Core Loss vs. Flux Density

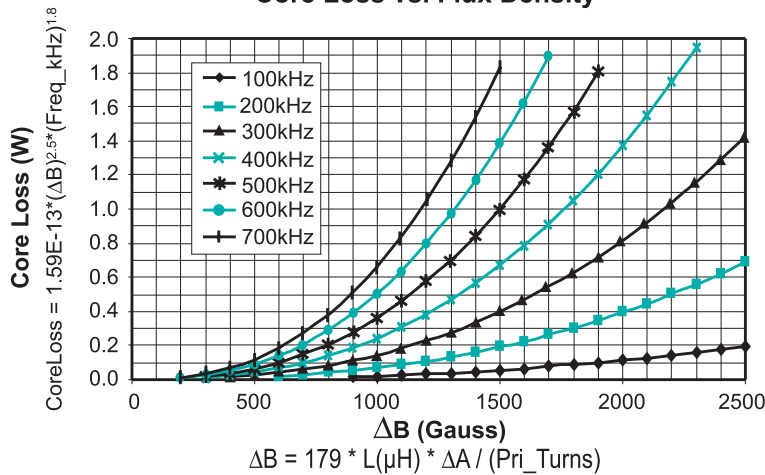

Temperature Rise vs. Power (W) Dissipation

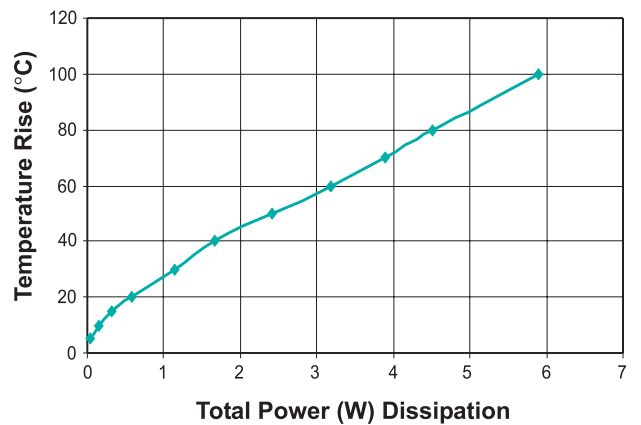

Total Power Dissipation = Copper Loss (W) + Core Loss (W)

Copper Loss (W) = $\text{Current (rms)}^2 * \text{DCR (m}\Omega) / 1000$
Core Loss (W) = per table

