

- ⊗ Surface Mount Package: Pick and Place Compatible
- ⊗ Moisture Sensitivity Level: 1
- ⊗ Storage Temperature: -55°C to +130°C
- ⊗ Reflow Peak Temperature: 235°C

Electrical Specifications @ 25 °C — Operating Temperature - 55 °C to +130 °C

Part 5 Number	Turns Ratio	Current 2 Rating (A)	Secondary Inductance (mH MIN)	DCR (mΩ MAX)		Hipot (VRMS)
				Primary (8-7)	Secondary (1-3)	
PL2035	1:50	20	0.50	0.75	1500	500

NOTES:

1. The temperature of component (ambient temperature plus temperature rise) must be within the specified operating temperature range.
2. The maximum current rating is based upon temperature rise of the component and represents the DC current which will cause a typical temperature rise of 40°C with no airflow when both one turn windings connected in parallel.
3. To calculate value of terminating resistor (Rt) use the following formula:

$$R_t (\Omega) = V_{REF} * N / (I_{peak_primary})$$
4. The peak flux density of the device must remain below 2000 Gauss. To calculate the peak flux density for uni-polar current use following formula:

$$B_{pk} = 37.59 * V_{REF} * (Duty_Cycle_Max) * 10^5 / (N * Freq_kHz)$$
 - * for bi-polar current applications divide Bpk (as calculated above) by 2.
5. Optional Tape & Reel packaging can be ordered by adding a "T" suffix to the part number (i.e. PL2035 becomes PL2035T).

Mechanical

Electrical Schematic

PL2035

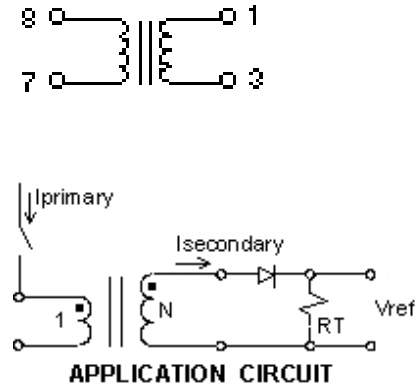
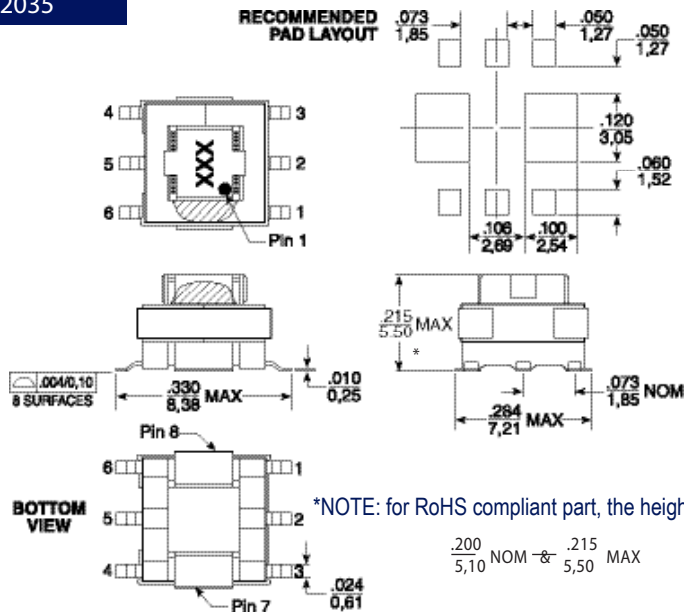

Tin/Lead Recommended Reflow Profile (Based on J-STD-020D)

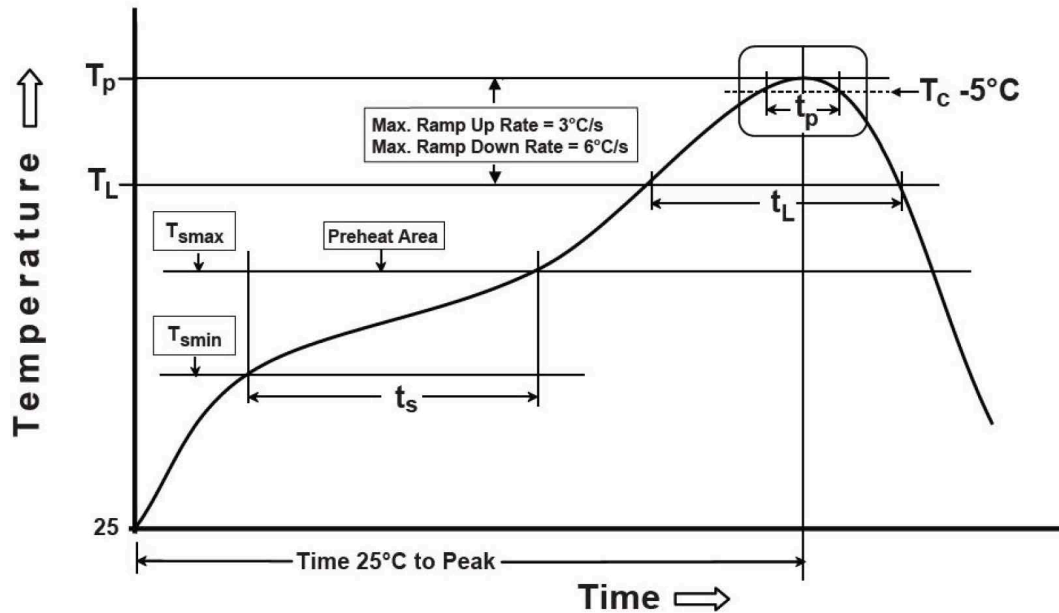

T_{SMIN} (°C)	T_{SMAX} (°C)	T_L (°C)	T_P (°C MAX)	t_s (s)	t_L (s)	t_p (s MAX)	Ramp-up rate (T_L to T_P)	Ramp-down rate (T_P to T_L)	Time 25°C to peak temperature (s MAX)
100	150	183	235	60-120	60-150	20	3°C/s MAX	6°C/s MAX	360

Notes:

1. All temperatures measured on the package leads.
2. Maximum times of reflow cycle: 2.

For More Information

iNRCORE, LLC
311 Sinclair Road
Bristol,
PA 19007-6812 U.S.A
Tel: + 1.215.781.6400
Fax: +1.215.7816430

**Global Sales Representatives
and Locations:** <http://www.inrcore.com>

Performance warranty of products offered on this data sheet is limited to the parameters specified. Data is subject to change without notice. Other brand and product names mentioned herein may be trademarks or registered trademarks of their respective owners. © Copyright, 2020. iNRCORE, LLC. All rights reserved.

