

SMT Current Sense Transformer

Ruggedized



- ⊗ Height: 5.5mm Max
- ⊗ Footprint: 8.4mm x 7.2mm
- ⊗ Max Current Rating: up to 20A
- ⊗ Frequency Range: 50kHz to 1MHz

Electrical Specifications @ 25 °C – Operating Temperature – 55 °C to +125 °C¹

Part Number	Turns Ratio	Current Rating (A)	Secondary Inductance (mH MIN)	DCR (mΩ MAX)		Hipot (V _{RMS})
				Primary (8-7)	Secondary (1-3)	
PL2264	1:100	20	2.00	0.75	5500	500

- Notes:
- The temperature of the component (ambient temperature plus temperature rise) must be within the specified operating temperature range.
 - The maximum current rating is based upon temperature rise of the component and represents the DC current which will cause a typical temperature rise of 40°C with no airflow when both one turn windings connected in parallel.
 - To calculate the value of the terminating resistor (R_t) use the following formula: $RT (\Omega) = V_{ref} * N / (I_{peak_primary})$.
 - The peak flux density of the device must remain below 2000 Gauss. To calculate the peak flux density for uni-polar current use following formula:
 $BPK = 37.59 * (Duty_Cycle_Max) * 105 / (N * Freq_kHz)$ * for bi-polar current applications divide BPK (as calculated above) by 2.
 - Optional Tape & Reel packaging can be ordered by adding a "T" suffix to the part number (i.e. PL2264 becomes **PL2264T**).
 - The "NL" suffix indicates an RoHS-compliant part number. Non-NL suffixed parts are not necessarily RoHS compliant, but are electrically and mechanically equivalent to NL versions. If a part number does not have the "NL" suffix, but an RoHS compliant version is required, please contact iNRCORE for availability.
 - This part is limited by core dissipation. The core can be run at 2000 gauss bipolar at frequencies up to 300 kHz, after 300 kHz the flux density recommended limits are as follows: 400kHz-1200 gauss, 500kHz-1000 gauss, 750kHz- 900 gauss, 1 MHz-800 gauss. B_{max} can be doubled for unipolar applications, as delta B is halved.

Mechanical

Electrical Schematic

XXXX

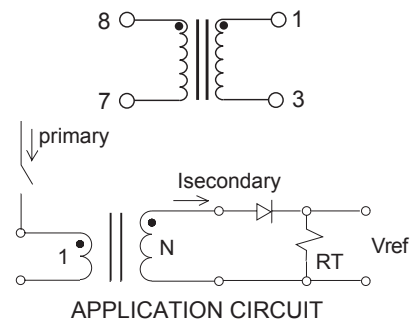
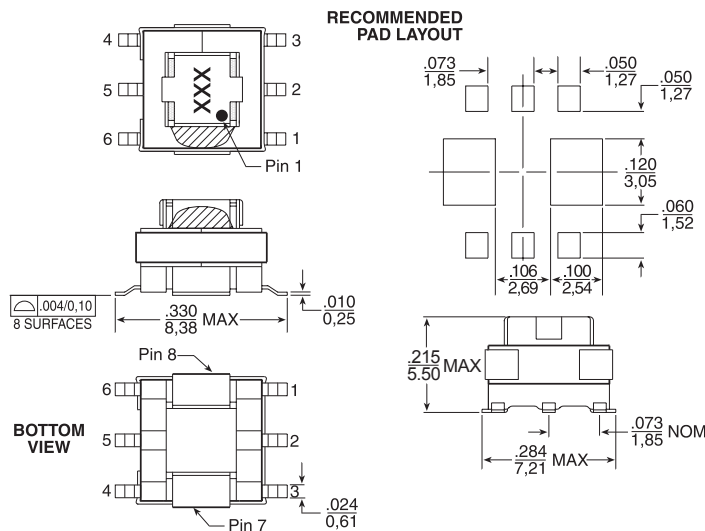

Dimensions: $\frac{\text{Inches}}{\text{mm}}$

Unless otherwise specified, all tolerances are: $\pm \frac{.010}{0,25}$



Tin/Lead Recommended Reflow Profile (Based on J-STD-020D)

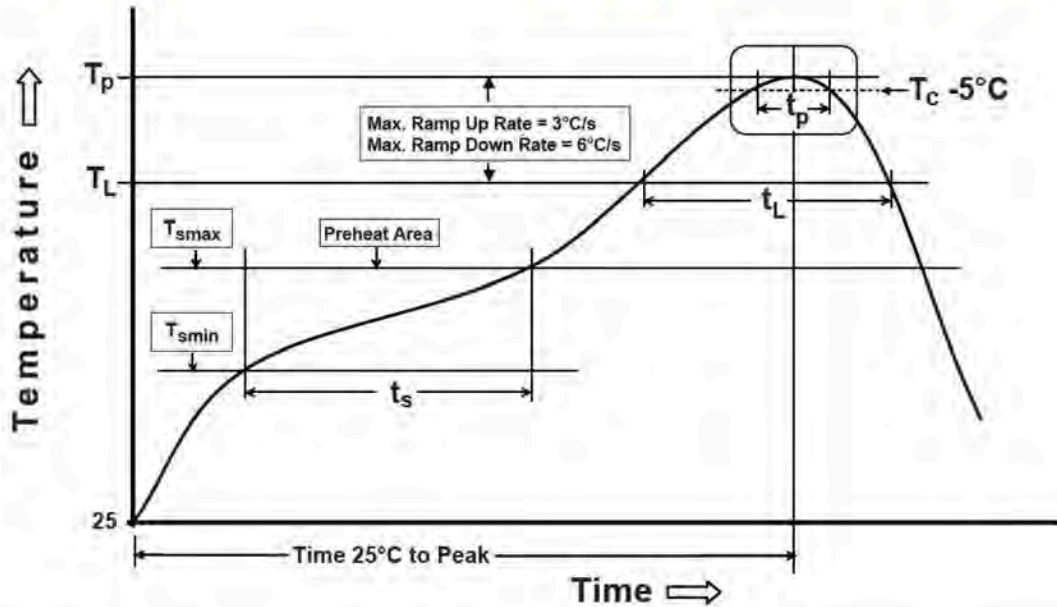

T_{SMIN} (°C)	T_{SMAX} (°C)	T_L (°C)	T_P (°C MAX)	t_s (s)	t_L (s)	t_p (s MAX)	Ramp-up rate (T_L to T_P)	Ramp-down rate (T_P to T_L)	Time 25°C to peak temperature (s MAX)
100	150	183	235	60-120	60-150	20	3°C/s MAX	6°C/s MAX	360

Notes:

1. All temperatures measured on the package leads.
2. Maximum times of reflow cycle: 2.

For More Information

iNRCORE, LLC
 311 Sinclair Road Bristol,
 PA 19007-6812 U.S.A
 Tel: + 1.215.781.6400
 Fax: +1.215.7816430

Global Sales Representatives and Locations:
<http://www.inrcore.com>

Performance warranty of products offered on this data sheet is limited to the parameters specified. Data is subject to change without notice. Other brand and product names mentioned herein may be trademarks or registered trademarks of their respective owners. © Copyright, 2020. iNRCORE, LLC. All rights reserved.

