

DASH NO	CABLES ACCOMMODATED	TABLE 1					CABLE ENTRY DIA	ASSEMBLE PER	CABLE TYPE		
		A DIM	B DIM	C FLATS	D FLATS	E DIA					
-7	TRC-50-2 TRC-75-2	1.165	.096	.438	.438	.500	.274	TAI-189	TRIAx		
-8	8227, BELDEN	1.740	.130	.625	.688	.750	.345	TAI-103	TWINAX		
-9	TWC-78-2 TWC-124-2	1.165	.096	.438	.438	.500	.285	TAI-102			
-A9 3	BL782, TIMES BL982, TIMES BL1242, TIMES									3	3
-10	RG-22 754E, AT&T									1.740	.130
-11	760A, AT&T										
-12	16PEVL, AT&T VI-AL, GENERAL	1.740	.130	.625	.688	.750	.485	TAI-128			
-13	TRF-59, TIMES										
-13A	8232, BELDEN										
-14	8233, BELDEN										
-23	250-3884, MICRODOT	1.165	.096	.438	.438	.500	.183	TAI-189		TRIAx	
-24	202-3934, MICRODOT										
-24A	9530A5117, RAYCHEM										
-25	T-43M, GENERAL										
-25A	5021H5331, RAYCHEM										
-26	7028A5518, RAYCHEM										
-27	1191PSJ2619EN, WOVEN 202-3927, MICRODOT 202-3942, MICRODOT										
-29	TWC-78-1/TWC-124-1A										
-30	761A, AT&T 8441, BELDEN										
-32	TRC-50-1										
-33	TRC-75-1										
-42	21-204, ESSEX 4463, CONSOLIDATED	1.740	.130	.625	.688	.750	.300	TAI-189	TRIAx		
-43	250-4044/250-4045 293-3930, MICRODOT										
-45	M27500-22TE2114 1100-66F, STANDARD										
-46	9860, BELDEN	1.165	.096	.438	.438	.500	.475	TAI-103	TWINAX		
-47	M177176-00002										
-49	TWAC-78-1F2										
-54	89207, BELDEN										
-55	89272, BELDEN	1.740	.130	.625	.688	.750	.250	TAI-102	TRIAx		
-56	GC875GCI, GRUMMAN										
-57	GC875GB1, GRUMMAN										
-58	GC875TM24H, GRUMMAN										
-59	GC875LNI, GRUMMAN										
-60	M177177, THERMATICS 380-10045, BOEING										
-64	7528A5314, RAYCHEM										

REV		DESCRIPTIONS	DATE	APPROVED
AD	ECO 52460		6/18/10	CSM

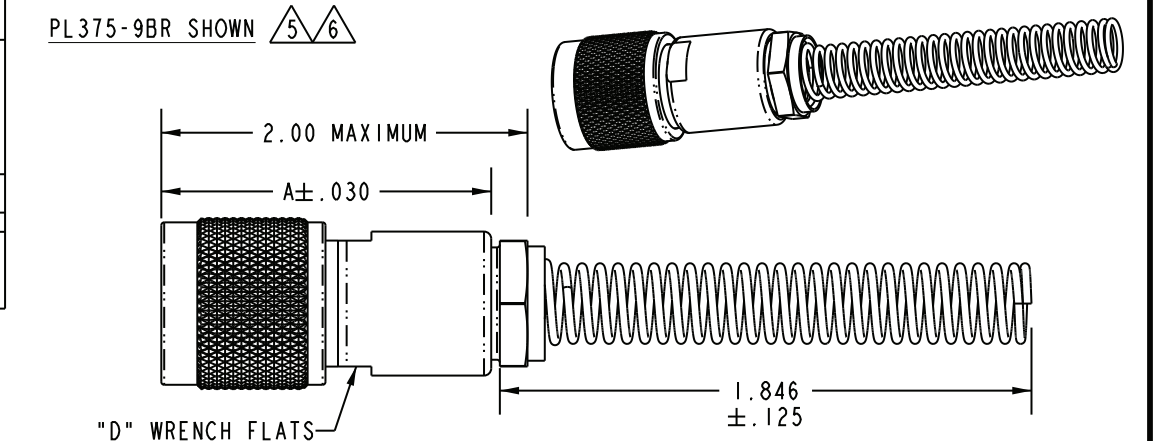
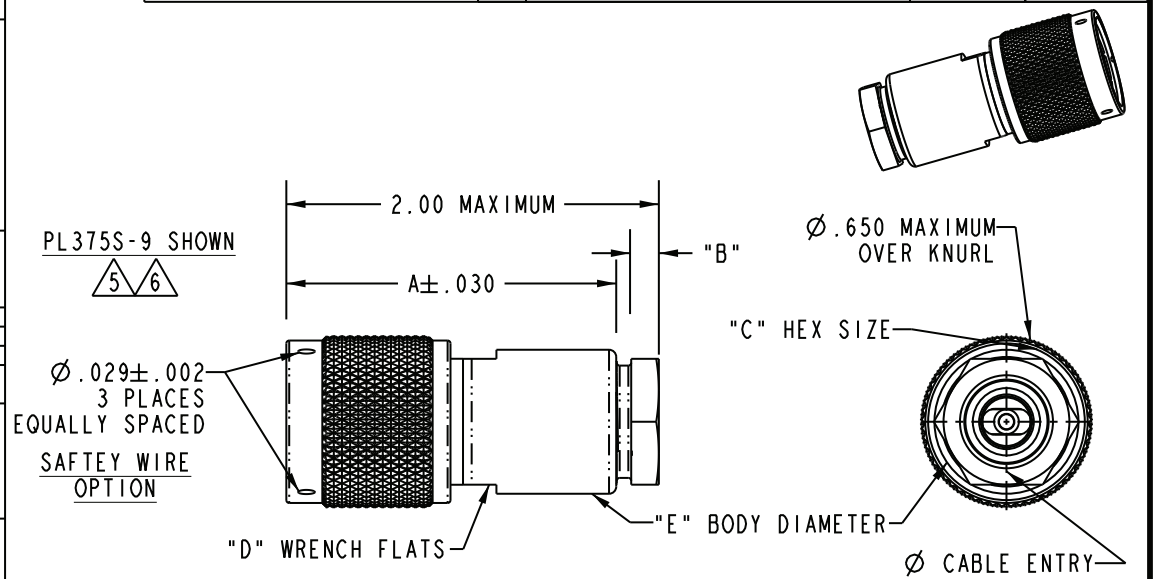

- 6 IF SAFETY WIRE TYPE & BEND RELIEF SPRING RECD ADD SUFFIX "SBR" TO MODEL NO (NOT AVAILABLE WITH CABLE GROUPS -8, -10, -11, -12, -13, -13A, -14, -46, & -54)
  - 5 IF BEND RELIEF SPRING RECD (SEE FIG 2) ADD SUFFIX "BR" TO MODEL NO (NOT AVAILABLE WITH CABLE GROUPS -8, -10, -11, -12, -13, -13A, -14, -46, & -54)
  - 4 IF SAFETY WIRE TYPE RECD ADD SUFFIX "S" TO MODEL NO (PL375S)
  - 3 CLAMP NUT OMITTED
  - 2 CONCENTRIC TWINAX/TRIAx TRT CABLE PLUG
  - 1 FINISH: TFS-1A (NICKEL)
- NOTES: UNLESS OTHERWISE SPECIFIED.

7. EXAMPLE OF COMPLETE MODEL NO:  
**PL375 S -7 BR**

BASIC MODEL NO

BEND RELIEF (OMIT IF NOT RECD)

SAFETY WIRE TYPE (OMIT IF NOT RECD)

DASH NO (CABLE GROUP, TABLE 1)

INTERPRET DRAWING PER MIL-STD-100. DIMENSIONS ARE IN INCHES AND INCLUDE FINISH THICKNESS UNLESS OTHERWISE SPECIFIED.		TOL: UNLESS SPECIFIED. .XX ± .02 .XXX ± .010 .XXXX ± .0010 ANGLE ± 1° 00' CRITICAL		<p>Cinch Connectivity Solutions 299 Johnson Ave. Ste. 100 Waseca, MN 56093 1-800-247-8256</p>	
DRW	BPK	7/29/11		MATERIAL:	
CHK	CSM	8/1/11		FINISH:	
QUALITY				TITLE: PL375 / PL375S PL375BR / PL375SBR	
MANUF				SIZE	CAGE CODE
APPROVED				Δ	14949
PROF TITLE NO		315-0011		DRAWING NO.	315-0011
SURFACE AREA				SCALE	1/1
		DO NOT SCALE DWG		DATE	5/23/73
				SHEET	1 OF 2