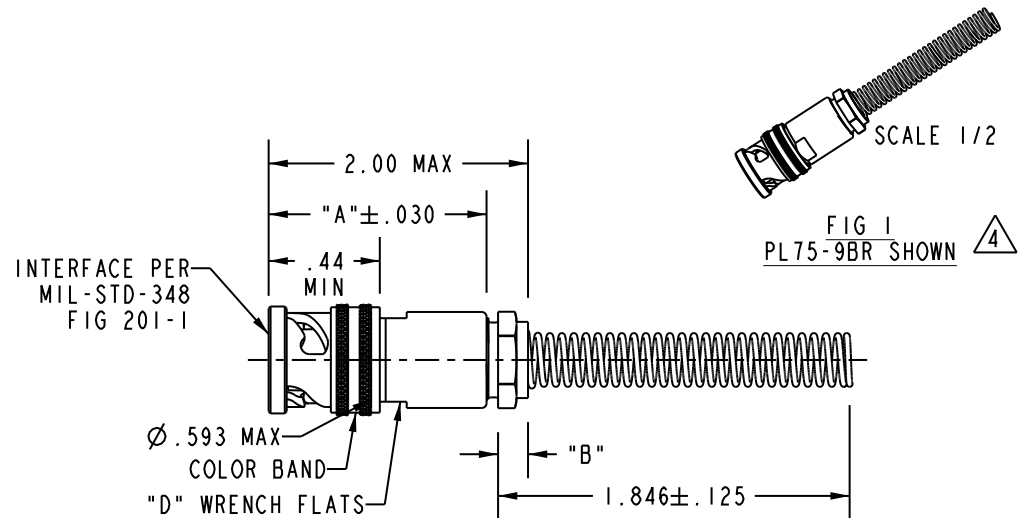
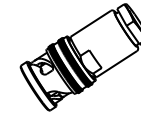
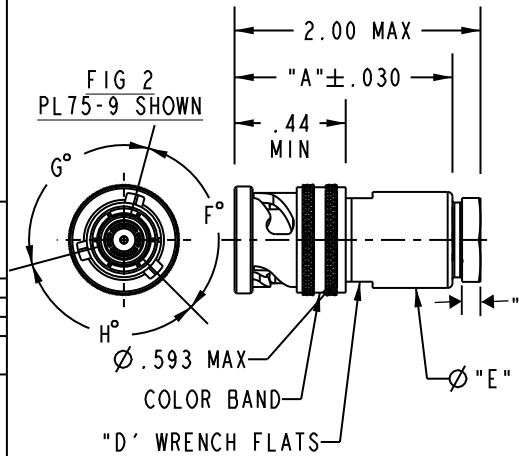

TABLE 1									
DASH NO	CABLES ACCOMMODATED	A DIM	B DIM	C FLATS	D FLATS	E DIA	CABLE ENTRY DIA	ASSEMBLE PER	CABLE TYPE
-7	TRC-50-2, MI77134-00001 TRC-75-2	1.135	.096	.438	.438	.500	.274	TAI-189	TRIAx
-8	8227, BELDEN	1.716	.130	.625	.688	.750	.345	TAI-103	TWINAX
-9	TWC-78-2 TWC-124-2, MI7745-RG 308	1.135	.096	.438		.500	.285	TAI-102	
-A9	BL782, TIMES BL982, TIMES BL1242, TIMES	1.135	$\triangle 3$	$\triangle 3$.500		TAI-102	TWINAX
-10	RG-22 754E, AT&T	1.716					.455	TAI-103	
-11	760A, AT&T						.345	TAI-103	TWINAX
-12	16PEVL, AT&T VI-AL, GENERAL		.130	.625	.688	.750	.485	TAI-128	
-13	TRF-59, TIMES						.362	TAI-129	TRIAx
-13A	8232, BELDEN						.352	TAI-165	
-14	8233, BELDEN						.510	TAI-129	TWINAX
-23	250-3884, MICRODOT						.183	TAI-189	
-24	202-3934, MICRODOT						.191	TAI-102	TWINAX
-24A	9530A5117, RAYCHEM						.200	TAI-189	
-25	T-43M, GENERAL						.285	TAI-102	TWINAX
-25A	5021H5331, RAYCHEM						.183	TAI-189	
-26	7028A5518, RAYCHEM						.183	TAI-189	TWINAX
-27	119TPS12619EN, WOVEN 202-3927, MICRODOT 202-3942, MICRODOT						.145	TAI-102	
-29	TWC-78-1/TWC-124-1A 761A, AT&T	1.135	.096	.438	.438	.500	.191	TAI-102	TWINAX
-30	8441, BELDEN						.235	TAI-102	
-32	TRC-50-1						.191	TAI-189	TRIAx
-33	TRC-75-1						.217	TAI-189	
-42	21-204, ESSEX 4463, CONSOLIDATED						.300	TAI-189	TRIAx
-43	250-4044/250-4045 293-3930, MICRODOT						.200	TAI-102	
-45	M27500-22TE2T14 1100-66F, STANDARD						.183	TAI-102	TWINAX
-46	9860, BELDEN	1.716	.130	.625	.688	.750	.475	TAI-103	
-47	MI77176-00002	1.135	.096	.438	.438	.500	.164	TAI-102	TWINAX
-49	TWC-78-1F2	1.716	.130	.625	.688	.750	.132	TAI-103	
-54	89207, BELDEN						.323	TAI-102	TRIAx
-55	89272, BELDEN						.250	TAI-102	
-56	GC875GCI, GRUMMAN						.191	TAI-189	QUADRAX
-57	GC875GB1, GRUMMAN						.191	TAI-102	
-58	GC875TM24H, GRUMMAN	1.135	.096	.438	.438	.500	.198	TAI-102	TRIAx
-59	GC875LNI, GRUMMAN						.198	TAI-189	
-60	MI77177-00002, THERMATICS 380-10045, BOEING						.217	TAI-189	TRIAx
-64	7528A5314, RAYCHEM						.183	TAI-189	

DATA CONTAINED IN THIS DOCUMENT IS PROPRIETARY TO EMERSON CONNECTIVITY SOLUTIONS AND SHALL NOT BE DISCLOSED, COPIED OR USED FOR PROCUREMENT OR MANUFACTURE WITHOUT EXPRESS WRITTEN PERMISSION

REVISIONS			
REV	DESCRIPTIONS	DATE	APPROVED
BS	ECO 52461	6/18/10	C. MONAHAN

TABLE 3				
KEYING LETTER	F DEGREES	G DEGREES	H DEGREES	COLOR BAND
NONE	120°	120°	120°	NONE
T	100°	150°	110°	RED
U	120°	130°	110°	ORANGE
V	115°	130°	115°	YELLOW
W	125°	110°	125°	GREEN
X	130°	100°	130°	BLUE
Y	110°	140°	110°	VIOLET
Z	100°	160°	100°	GRAY
S	135°	135°	90°	WHITE



5. EXAMPLE OF COMPLETE MODEL NO:
 PL75 T -9 BR $\triangle 4$
 BASIC MODEL NO. ———— BEND RELIEF (OMIT IF NOT REQD)
 POLARIZATION LETTER ———— DASH NO (CABLE GROUP, SEE TABLE 1)
 NONE REQD FOR STD ———— POLARIZATION (SEE TABLE 3)

$\triangle 4$ IF BEND RELIEF SPRING REQUIRED (SEE FIG 1) ADD SUFFIX "BR" TO MODEL NUMBER (NOT AVAILABLE WITH CABLE GROUPS -8, -10, -11, -12, -13, -13A, -14, -46, & -54)

$\triangle 3$ CLAMP NUT OMITTED

2. CONCENTRIC TWINAX/TRIAx 3-LUG TRB CABLE PLUG

1. PLATING: 310-0002-XX PER TFS-1 OR -U FOR UNPLATED

INTERPRET DRAWING PER MIL-STD-100. DIMENSIONS ARE IN INCHES AND INCLUDE FINISH THICKNESS UNLESS OTHERWISE SPECIFIED.	TOL: UNLESS SPECIFIED. .XX ± .02 .XXX ± .010 ANGLE ± 1°
DRW M. JOHNSON 3-18-09	MATERIAL:
CHK LM 4/1/09	TITLE:
QUALITY	PL75/T/U/V/W/ X/Y/Z/S/BR
MANUF	FINISH:
APPROVED	SIZE CAGE CODE DRAWING NO. REV. \triangle 14949 310-0002 BS
PROF TITLE NO. 310-0002	DO NOT SCALE DWG SCALE 1/1 DATE 1-12-66 SHEET 1 OF 2