

RED INDICATES ORIGINAL

DWG SIZE C	DATA CONTAINED IN THIS DOCUMENT IS PROPRIETARY TO TROMPETER ELECTRONICS, INC. AND SHALL NOT BE DISCLOSED, COPIED OR USED FOR PROCUREMENT OR MANUFACTURE WITHOUT EXPRESS WRITTEN PERMISSION.			REVISIONS		310-0073	SH 1
	REV	ED	DESCRIPTION	DWN	APPROVED	DATE	
	G	12387	ADDED -224 & -225; ADDED NOTE [4] SHEET 2; SEE ECO	DKC	WM NAM.	7/22/88	

DASH NO	CABLES ACCOMMODATED	A HEX	B MAX	ASSEMBLE PER
-201	M17/176-00002	.344	1.77	TAI-169
-202	TWC-78-1			
-203	TWC-124-1A			
-204	10802, RAYCHEM			
-205	TWAC-78-1F2			
-206	7B26D0130, RAYCHEM			
-207	B3310 BELDEN			
-208	202-3827 MICRODOT			
-209	202-3842 MICRODOT			
-210	B451 BELDEN			
-211	202-3934 MICRODOT	.344	1.52	TAI-161
-212	2524E0114, RAYCHEM			
-213	TWC-78-2			
-214	TWC-124-2			
-215	BL-982 TIMES			
-216	BL-1242 TIMES			
-217	GCB75TM24H, GRUMMAN			
-218	EPO 221688, RAYCHEM			
-219	2526D1114, RAYCHEM			
-220	GCB75RR1, GRUMMAN			
-221	10614, RAYCHEM	.344	1.77	TAI-169
-222	10613, RAYCHEM			
-223	HMS2-1149, HUGHES			
-224	TWCP-124-3			
-225	PS689PL, PRIME STOCK			
-301	GCB75SC1, GRUMMAN			
-302	GCB75GB1, GRUMMAN 5022E5111, RAYCHEM			
-303	7528A5314, RAYCHEM			
-304				
-305	M17/177-00001, THERMATICS			
-306	TRC-50-2 M17/134-00002			
-307	TRC-75-1			
-308	TRC-75-2			
-309	TRC-50-1			

INCH	MM
.005	0.13
.030	0.76
.050	1.27
.344	8.74
.484	12.29
.933	23.70
1.00	25.40
1.25	31.75
1.317	33.45
1.47	37.34
1.52	38.61
1.75	44.45
1.76	44.70
1.77	44.96

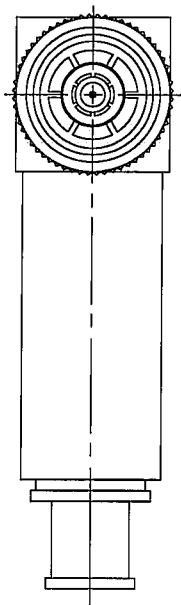
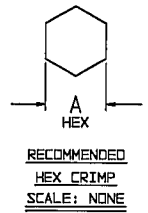

-201 SHOWN

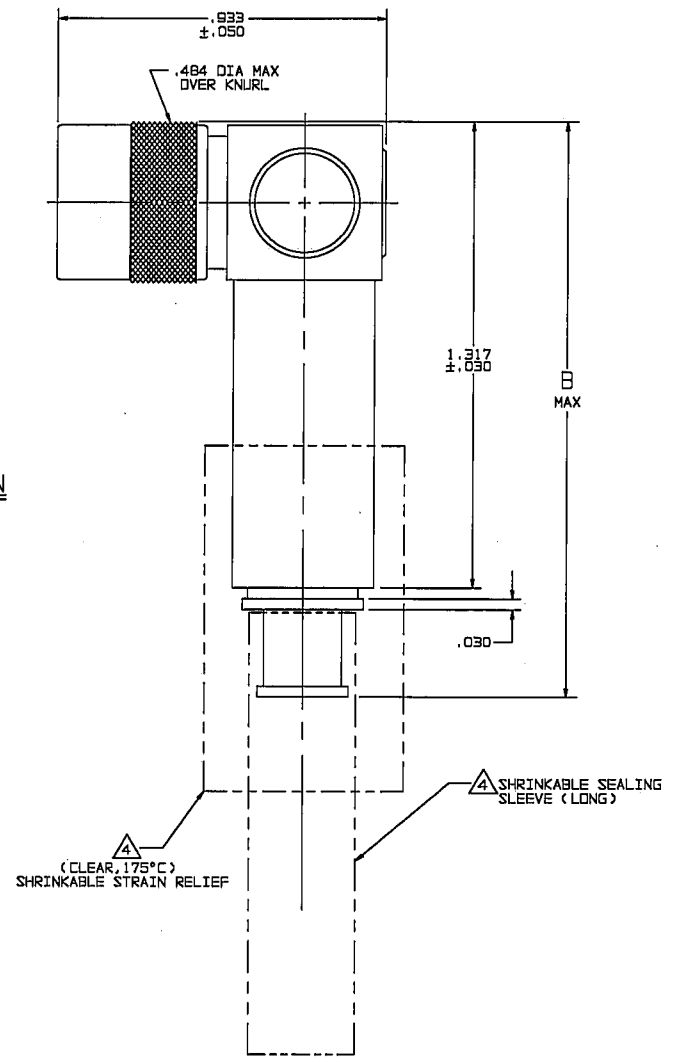

- A** 1 SHRINKABLE STRAIN RELIEF AND/OR SHRINKABLE SEALING SLEEVE SUPPLIED LOOSE AS FOLLOWS:
- a. CABLE GROUPS -201 THROUGH -210, -217 THROUGH -223, -301, -302, -303, -305, -307 & -309
 - 1 SHRINKABLE STRAIN RELIEF (1.00 LONG)
 - 1 SHRINKABLE SEALING SLEEVE (1.25 LONG)
 - b. CABLE GROUPS -211 THROUGH -216, -306 & -308
 - 1 SHRINKABLE STRAIN RELIEF (1.75 LONG)
3. CONCENTRIC TWINAX/TRIAx TTM THREADED RIGHT ANGLE FULL CRIMP CABLE PLUG
2. FINISH: TFS-1A (NICKEL)
1. ALL DIM ARE IN INCHES

6. EXAMPLE OF COMPLETE MODEL NO:
PLR3155AC S-201
 BASIC MODEL NO ———— CABLE GROUP DASH NO
 SAFETY WIRE ————
5. EXAMPLE OF COMPLETE PART NO:
310-0073 S-201
 BASIC PART NO ———— CABLE GROUP DASH NO
 SAFETY WIRE ————

QTY	DESCRIPTION	PART NUMBER	ITEM
TOL UNLESS SPECIFIED +.005 ± .03 .005 ± .005 NONE NONE	TROMPETER ELECTRONICS, INC.	PLR3155AC/ PLR3155ACS	
DWN	DKC	5-19-88	MATERIAL
CHK	WM	6-2-88	CODE IDENT
ENGR			DRAWING NO.
APPR	WM	7/16/88	14949
			310-0073
			REV G
NEXT ASSY			SCALE 4/1
			DATE 4/19/89
			SHEET 1 OF 2