

# PM5450 HyPHY-20Gflex

## High-Capacity Single-Chip Multi-Rate/Multi-Protocol OTN Processor

### Summary

The PM5450 HyPHY-20Gflex device represents Microchip's 2nd generation of OTN-enabled, high-capacity system-on-a-chip solutions for Multi-Service Provisioning Platforms (MSPPs), Wavelength Division Multi-plexing (WDM) Platforms, Reconfigurable Optical Add-Drop Multiplexers (ROADMs), Optical Transport Platforms (OTPs), Packet-OTPs and Optical Access Platforms. The HyPHY-20Gflex brings ODU0 and ODUflex capabilities to universal multi-rate, multiservice line, transponder and muxponder cards.

The HyPHY-20Gflex is pin-compatible to the PM5420 HyPHY 20G and delivers unprecedented single-chip scalability and feature integration to enable optimal footprint, power and cost efficiency. The HyPHY-20Gflex provides a rich set of framing, mapping and multiplexing resources for a variety of protocols, including OTN, SONET/SDH, Ethernet, Fibre Channel, ESCON, FICON and multi-rate bit transparent services such as video.

### The HyPHY-20Gflex Adds Several Capabilities to the HyPHY Family

- Support for 32x ODU0 and 16x ODUflex
- G.709 compliant GMP mapping
- G.709 compliant mapping of FC-1200
- Full suite of Ethernet and SONET/SDH ingress and egress PMON
- Two stage ODUjk multiplexing
- 16x OTU1 support (8 more than HyPHY 20G)
- VLAN aggregation of GE traffic onto XAUI interface
- OIF compliant OTN over packet format header extensions

### Benefits

- Carrier OPEX and CAPEX savings
  - Simplifies equipment deployment and network management by enabling hybrid TDM/packet platforms
  - Dramatically reduces cost of ownership by simplifying line card inventory management
- Unprecedented service delivery flexibility
  - Supports per-port configurable OTN, SONET/SDH, Ethernet, SAN and bit transparent client services
  - Rich suite of client service mappings into OTN & SONET/SDH
  - OTN Tri-FEC for maximum network interoperability
  - Enables full SNCP-base protection switching for meshed network topologies
- Processor-based Carrier Ethernet
  - Flexible implementations of Synchronous Ethernet, IEEE 1588 Precision Timing Protocol (PTP) and Ethernet Link OAM (IEEE 802.3ah)
- Optimized power and footprint for OEMs
  - Direct connect to SFP, SFP+ (limiting) and XFP modules for all rates with no external SERDES or PLL components required
  - All frequencies derived from a single 155.52 MHz reference clock
  - Single-chip solution for muxponders, transponders and optical access platforms
  - Glueless interconnect to many off-the-shelf NPs and fabrics

## Block Diagram

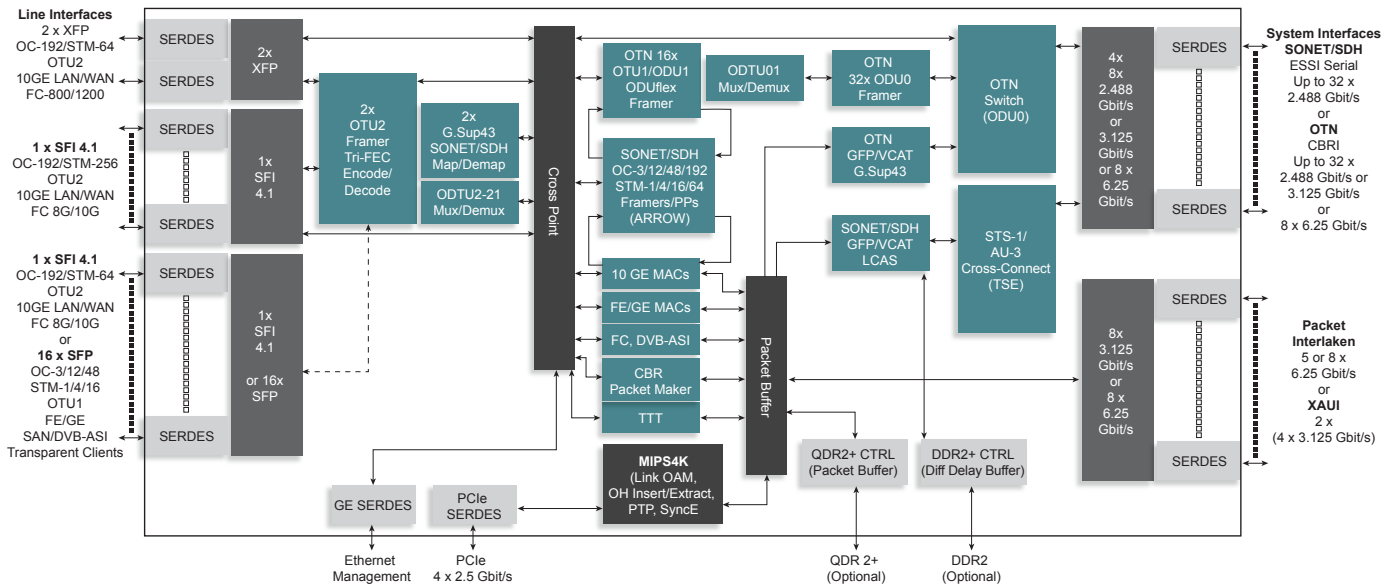

## Product Highlights

### SFP Client Interfaces

- 16x multi-rate SERDES for direct connection to SFP optical transceivers, independently tunable from 16 Mbit/s to 5 Gbit/s
- Any-Service Any-Port configurability
  - OTU1 (up to 16)
  - OC-3/12/48 or STM-1/4/16
  - 100/1000 Mbps full-duplex Ethernet
  - Bit transparent clients, including, but not limited to DVB-ASI, SD-SDI, HD-SDI, DV6000, ISC, ISCIll and 2.5G/5G Infiniband
  - Fibre Channel FC-15, FC-25, FC-50, FC-100, FC-200, FC-400, FICON and ESCON
  - CPRI clients up to 4.9 Gbit/s

### 10G Client and WAN Interfaces

- 2x multi-rate SERDES for direct connection to XFP/SFP+ (limiting) modules, independently tunable from 8.5 Gbit/s to 11.32 Gbit/s
- 2x SFI 4.1 interface for chip-to-chip interconnect or for direct connection to MSA modules
- Any-Service Any-Port configurability
  - OTU2 (including overclocked rates up to 11.32 Gbit/s)
  - OC-192/STM-64
  - 10GE-LAN
  - 10GE-WAN
  - Fibre Channel (FC-800 and FC-1200)
  - CPRI 9.8304 Gbit/s client

### SONET/SDH Subsystem (ARROW + TSE)

- Integration of field-proven CHES SONET/SDH IP, reducing development cycles through reuse of CHES software base
- SONET/SDH framing, overhead and high-order pointer processing
- Tandem connection monitoring
- Transport overhead transparency
- BLSR and MSSPRing protection switching with alarm processing, K-byte express, automatic payload configuration
- Non-blocking 100 Gbit/s STS-1/AU-3 cross-connect
- 50 Gbit/s of floating delay management to adapt between frame alignment domains
- TOH byte insertion and extraction
- Active and standby configuration memory page support permits new switch settings to be updated in one page while the TSE operates from the control settings of the other page

### Fibre Channel Subsystem

- FICON, ESCON and Fibre Channel (FC-12, 25, 50, 100, 200, 400, 800)
- Performs 8B/10B Physical Coding Sub-layer (PCS) on a per-link basis with loss of signal and transmission error monitoring
- Per-link rate adaptation to bridge between local and transmit link timing domains
- FC-1200 is supported as a transparent client

## Ethernet Subsystem

- Integrated IEEE 802.3 compliant media access controllers (MAC)
- Integrated 10 GE WAN Interface sublayer (WIS) framing and descrambling
- 4B/5B, 8B/10B and 64B/66B physical coding sub-layer (PCS) on a per link basis for FE, GE and 10GE respectively
- Lossless IEEE 802.3 local flow control; integrated packet buffers
- Comprehensive per-port Ethernet statistics
- Frame delineation and generation with configurable IPG, Preamble and CRC
- Transparent transmission of VLAN tagged Ethernet frames
- Frame sizes of 64 bytes to 9.6 Kbytes
- Dynamic programmable depth full-packet store-and-forward buffers for burst tolerance and rate adaptation
- Transmit and receive of IEEE 802.3ah Link OAM, LACP and Management VLAN messages
- Firmware-based (MIPS4K CPU), hardware assisted G.8261 Synchronous Ethernet and IEEE 1588v2 PTP Ethernet timing
- On-chip central packet buffer

## OTN Subsystem

- Compatible with ITU-T G.709, ITU-T G.798 and ITU-T G.975
- Supports 32x ODU0 and 16x ODUflex(CBR) and ODUflex(GFP)
- Flexible OTU, ODU and OPU overhead/data processing and frame alignment
- Transmit and receive facility and terminal loop back configurations
- Two-stage ODU multiplexing
- Support for GMP multiplexing as well as 1.25G Timeslots
- Up to six levels of Tandem Connection Monitoring (TCM)
- Independent performance counters for the accumulation of BIP-8, BEI and other error conditions with optional interrupts
- O-E-O regeneration with adaptive clocking using Microchip's OTN Phase Signaling Algorithm (OPSA)

## Forward Error Correction (FEC)

- Two instantiations of independently-configurable Tri-FEC for OTU2
  - Interoperable G.709 RS (255, 239) FEC with 6.2 dB coding gain at 10-15 BERout
  - Interoperable G.975.1 Annex I.4 Strong FEC (8.9 db gain at BERout = 10-15 @ 7% OH)
  - Interoperable G.975.1 Annex I.7 Strong FEC (8.4 db gain at BERout = 10-15 @ 7% OH)
- Comprehensive statistics for use in EDC tuning, limited amplifier tuning and performance monitoring

## Client Mapping into OTN and SONET/SDH

- Maps a wide variety of protocols into OTN and SONET/SDH
- Encapsulates packet streams into ITU-T G.7041 GFP-F, GFP-T, HDLC, LAPS or PPP
- Inserts and extracts GFP client management frames (CMF) as well as LCP, NCP and BCP control frames
- OTN client mapping
  - AMP, BMP, and GMP as per G.709
  - TTT mode for mapping clients such as GE into ODU0
  - ODUflex(CBR) and ODUflex(GFP)
  - High-order (ODU1) virtual and contiguous concatenation performed according to G.709
  - Available OPTM for mapping/multiplexing of sub-ODU1 client data into OTN
  - GFP with extension headers for multiplexing of sub-ODU1 client data streams into ODUks or OPTM tributary slots
  - OPSA for rate encoding and adaptation of transparent client data streams over OTN
  - 10GE mapping into OTN compliant with ITU G.Sup43 6.1, 6.2, 7.1, 7.2 and 7.3
  - FC-1200 mapping as per G.709
- SONET/SDH client mapping
  - High-order (STS-1-Xv/VC-3-xv & STS-3c-Xv/VC-4-Xv) virtual and contiguous concatenation performed according to ITU-T G.707 and ANSI T1.105
  - Up to 64 SONET/SDH virtual concatenation groups (VCGs) supported
  - Hitless Link Capacity Adjustment Scheme (LCAS) according to ITU-TG.7042
  - Up to 128 ms of differential delay between VCG members

## System Expansion Interfaces

- SONET/SDH
  - 4 x 8 x 2.488 Gbit/s ESSI serial links (up to 16 x working/16 x protect) supporting slicing and de-slicing for byte, nibble, di-bit, and bit modes
- OTN
  - 4 x 8 x lanes of CBRI links (up to 16 x working/16 x protect) configurable to 2.48832 Gbit/s or 3.125 Gbit/s
  - 1 x 8 lanes of CBRI links operating at 6.25 Gbit/s
  - Enables grooming of ODUk using off-the-shelf packet fabric
  - CBRI and ESSI can be configured to run simultaneously (in groups of eight links)
- Packet traffic
  - 1 Interlaken v1.1 interface configurable to 5 or 8 lanes at 6.25 Gbit/s
  - 2 x XAUI interfaces (2 x 4 lanes at 3.125 GHz), including support for VLAN aggregation
  - 2 x extended XAUI mode (2 x 4 lanes at 3.125 GHz) that adds format and flow-control channelization extensions to 802.3ae