

Prodigy®/CME Machine Controller Board



Prodigy®/CME Machine Controller Boards

provide high performance motion control for medical, scientific, automation, industrial, and robotic applications. Available in 1, 2, 3, and 4-axis configurations, these boards support DC Brush, Brushless DC, and step motors and allow user-written C-language code to be downloaded and run directly on the board. The Prodigy/CME Machine Controller has on-board Atlas® amplifiers that eliminate the need for external amplifiers. To build a fully functioning system only a power supply, motors, and cabling are needed.

Built on the Magellan Motion Control IC

Based on PMD's industry-leading Magellan® Motion Processor, the Prodigy/CME Machine Controller boards provide user-selectable profile modes including S-curve, trapezoidal, velocity contouring, and electronic gearing with on-the-fly parameter change. Servo loop compensation utilizes a full 32-bit position error, PID with velocity and acceleration feedforward, integration limit and dual biquad filters for sophisticated control of complex loads.

On-Board Amplifiers

Up to four on-board Atlas amplifiers provide high performance amplification for even the most demanding applications. These compact and powerful units provide field oriented control, safety monitoring, and industry-leading drive efficiencies.

Easy to Use and Program

The Pro-Motion® GUI makes it easy to set-up and analyze system parameters and motion performance. PMD's C-Motion and VB-Motion® libraries simplify the program development process and allow the use of industry standard C/C++ or Visual Basic programming languages.

FEATURES

- Complete all-in-one machine controller
- Available in 1, 2, 3, and 4-axis configurations
- Uses PMD's advanced Magellan® Motion Processor
- Supports DC Brush, Brushless DC, and step motors
- On-board high performance Atlas® amplifiers
- S-curve, trapezoidal, electronic gearing, and velocity-contouring
- Ethernet, CANbus and serial communications
- Board-level execution of user application code at 96 MIPS
- High speed loop rate: 50 μ sec/axis
- Up to 256 microsteps per full step resolution
- Up to 1KW peak output power per axis
- Extensive fault detection including over and undervoltage, motor short, and overtemp
- Single voltage supply drives motors and board logic
- Incremental quadrature and Absolute SSI encoder support
- 6-step commutation and field oriented control modes
- Profile and servo changes on-the-fly
- Advanced PID filter with feedforward and dual biquad filters
- High-speed hardware performance trace (up to 468 KB)
- 8 channels of high precision 16-bit analog input and output
- 12+ channels of general purpose digital I/O
- Two directional limit switches, high speed index, and home inputs per axis
- C-Motion Engine development tools
- Support for external amplifiers via +/- 10V analog output
- Includes Pro-Motion®, C-Motion® and VB-Motion® development software

CONFIGURATION

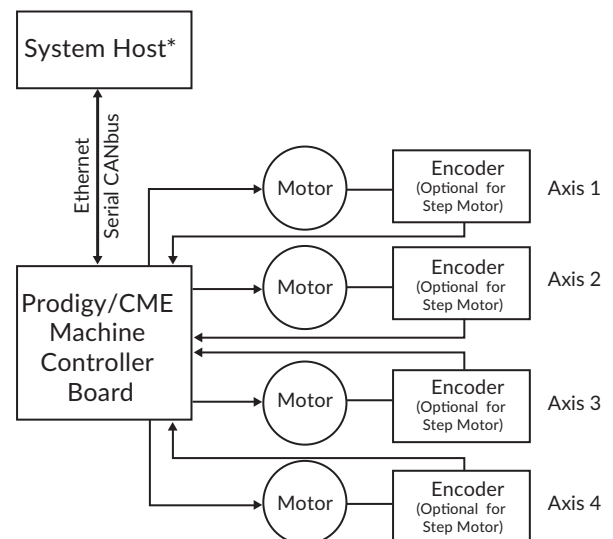

*System host optional

Technical Overview

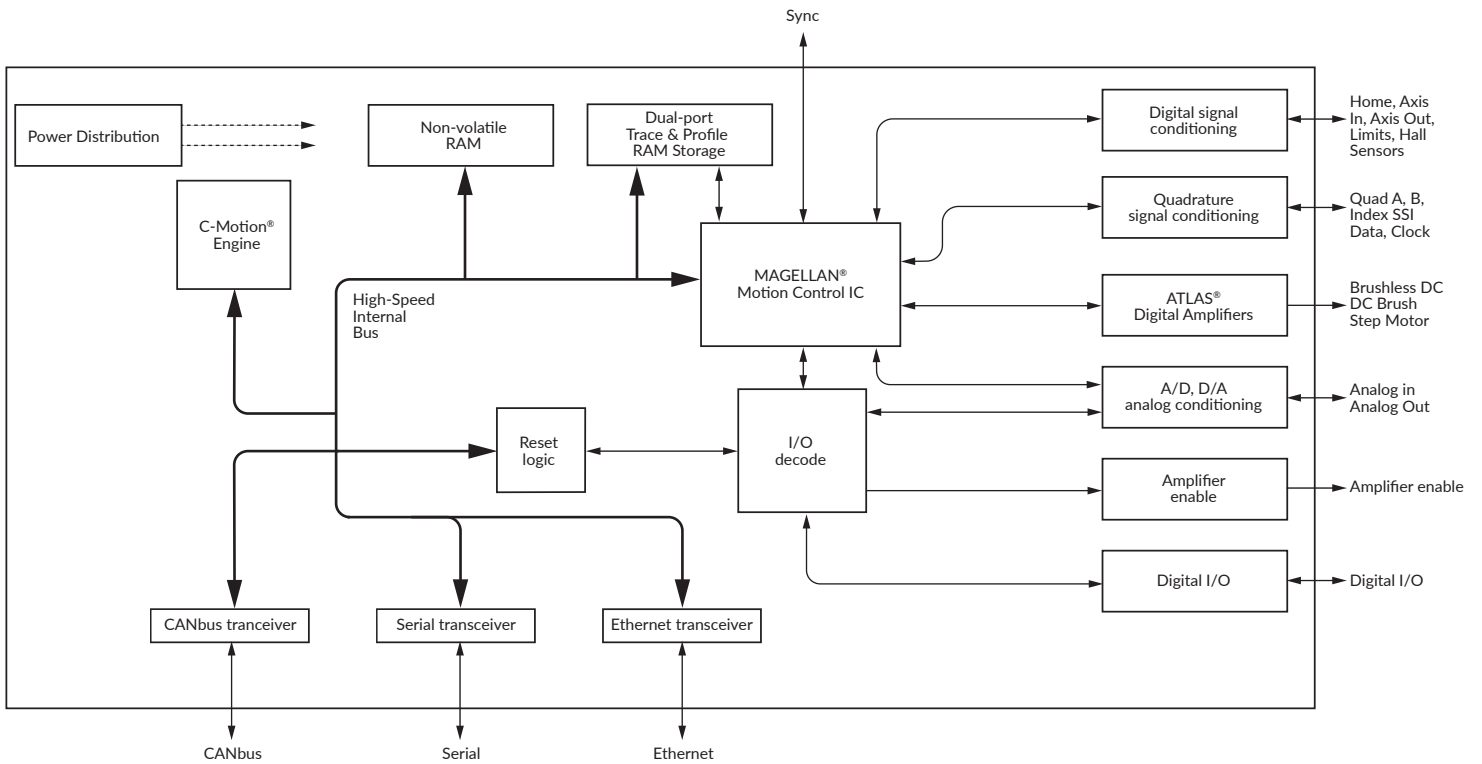

SPECIFICATIONS

	Machine Controller
Number of axes supported	1, 2, 3 or 4 axes
Supported motor types	DC Brush, Brushless DC, Step motor
Servo loop rates	51.2 μ sec to 1.6 sec. Minimum depends upon number of enabled axes and use of trace
Encoder formats supported	Quadrature, Absolute SSI
Quadrature decode rate	40 Mcounts/sec
Capability for onboard amplifier	Yes, Atlas Digital Amplifier
Motor output signals	Analog \pm 10V
General purpose digital I/O	8 bi-directional, 4 input, 4 output
General purpose analog input	8 16-bit channels (\pm 10V)
General purpose analog outputs	8 16-bit channels (\pm 10V)
Limit switches	2 per axis: one for each direction of travel
User program memory	256 KB Flash / 8 KB RAM
User program stack memory	8 KB RAM
Dual ported RAM	128 KB or 468 KB (enhanced memory option)
Communication modes	Serial, CANbus, Ethernet
Dimensions	7.80" x 4.88" x .78" (19.8cm x 12.4cm x 1.98cm)
On-board amplifier voltage range	12 - 56V
On-board amplifier continuous current output	DC Brush Motor: 14 ADC Brushless DC Motor: 10 Arms Step motor: 9Arms

ATLAS® Digital Amplifiers

ATLAS® Digital amplifiers are compact single-axis amplifiers that provide high performance torque control of DC brush, brushless DC, and step motors. They are packaged in a Compact or Ultra Compact solderable module and utilize standard through-hole pins for all connections.

Voltage Input	12-56 VDC
Microstepping resolution	256
PWM frequency	20, 40, 80 kHz
Current Loop rate	20 kHz
Power rating options	75W, 250W, 500W



Mechanical Dimensions

Ultra Compact size:
1.05" x 1.05" x .53" (27mm x 27mm x 13mm)
Compact size:
1.52" x 1.52" x .60" (39mm x 39mm x 15mm)

Profile modes

S-curve point-to-point:	Position, velocity, acceleration, deceleration, jerk
Trapezoidal point-to-point:	Position, velocity, acceleration, deceleration
Velocity-contouring:	Velocity, acceleration, deceleration
Electronic gearing:	Encoder trajectory position of one axis used to drive a second axis. Master and slave axes and gear ratio parameters

Filter modes

Scalable PID with Velocity, Acceleration feedforward, Integration limit, Offset bias, Dual biquad filter, Settable derivative sampling time, Output motor command limiting.

Development Tools

1 EASY START-UP Developers Kit

INCLUDES

- Prodigy Machine Controller Developer Kit
- Pro-Motion software
- Software Development Kit (SDK) with C-Motion
- Complete manual set
- Complete cable and prototyping connector set

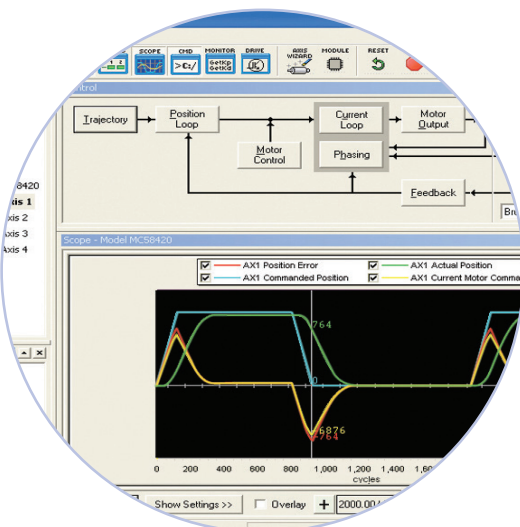

2 TUNE & OPTIMIZE Pro-Motion® GUI

Pro-Motion is a sophisticated, easy-to-use Windows-based exerciser program for use with PMD motion control ICs, modules, and boards.

FEATURES

- Motion oscilloscope graphically displays processor parameters in real-time
- Autotuning
- Ability to save and load settings
- Axis wizard
- Distance and time units conversion
- Motor-specific parameter setup
- Axis shuttle performs programmable motion between two positions
- Communications monitor echoes all commands sent by Pro-Motion to the board
- Advanced Bode analysis for frequency machine response

3 BUILD THE APP C-Motion®

C-Motion is a complete, easy-to-use, motion programming language that includes a source library containing all the code required for communicating with PMD motion ICs, board, and modules.

C-MOTION FEATURES INCLUDE:

- Extensive library of commands for virtually all motion design needs
- Develop embeddable C/C++ applications
- Complete, functional examples
- Supports PC/104, serial, CAN, Ethernet, and SPI communications

```
code for executing a profile and trace...
captured in this example could be used for tuning the Pro...
trace buffer wrap mode to a one time trace
TraceMode(hAxis1, PMDTraceOneTime);

at the processor variables that we want to capture
SetTraceVariable(hAxis1, PMDTraceVariable1, PMDAxis1,
SetTraceVariable(hAxis1, PMDTraceVariable2, PMDAxis1, P
SetTraceVariable(hAxis1, PMDTraceVariable3, PMDAxis1, P

// set the trace to begin when we issue the next update command
SetTraceStart(hAxis1, PMDTraceConditionNextUpdate);

// set the trace to stop when the MotionComplete event occurs
SetTraceStop(hAxis1, PMDTraceConditionEventStatus,
PMDEventMotionCompleteBit, PMDTraceStateHigh);
SetProfileMode(hAxis1, PMDTrapezoidalProfile);

set the profile parameters
SetPosition(hAxis1, 200000);
SetVelocity(hAxis1, 0x200000);
SetAcceleration(hAxis1, 0x1000);
SetDeceleration(hAxis1, 0x1000);

tion
;
```