

## PS2565-1, PS2565L-1, PS2565L1-1, PS2565L2-1

R08DS0201EJ0100

Rev.1.00

HIGH ISOLATION VOLTAGE AC INPUT RESPONSE TYPE

Dec 25, 2020

### DESCRIPTION

The PS2565-1 is optically coupled isolators containing GaAs light emitting diodes and an NPN silicon phototransistor.

The PS2565-1 is in a plastic DIP (Dual In-line Package) and the PS2565L-1 is lead bending type (Gull-wing) for surface mount.

The PS2565L1-1 is wide lead bending type.

The PS2565L2-1 is wide lead bending type for surface mount.

### FEATURES

- AC input response
- High isolation voltage (BV = 5 000 Vr.m.s.)
- High collector to emitter voltage ( $V_{CE0} = 80 \text{ V}$ )
- High current transfer ratio (CTR = 200 % TYP.)
- High-speed switching ( $t_r = 3 \mu\text{s}$  TYP.,  $t_f = 5 \mu\text{s}$  TYP.)
- Ordering number of taping product: PS2565L-1-F3 : 2 000 pcs/reel  
 : PS2565L2-1-F3 : 2 000 pcs/reel
- Pb-Free product
- Safety standards
  - UL approved: UL1577, Double protection
  - CSA approved: CAN/CSA-C22.2 No. 62368-1, Reinforced insulation
  - BSI approved: BS EN 62368-1, Reinforced insulation
  - SEMKO approved: EN 62368-1, IEC 62368-1, Reinforced insulation
  - NEMKO approved: EN 62368-1, Reinforced insulation
  - FIMKO approved: EN 62368-1, Reinforced insulation
  - DEMKO approved: EN 62368-1, Reinforced insulation
  - VDE approved: DIN EN 60747-5-5 (Option)

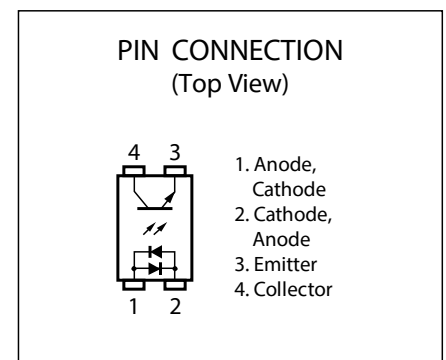

### APPLICATIONS

- Telephone/FAX.
- FA/OA equipment
- Programmable logic controller

**PACKAGE DIMENSIONS (UNIT: mm)**

**DIP Type**

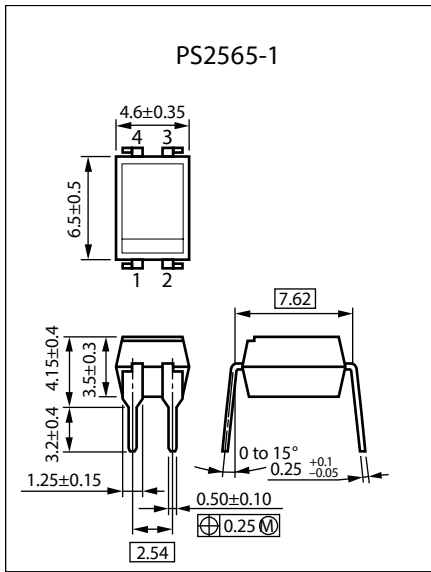

**Wide Lead Bending Type**

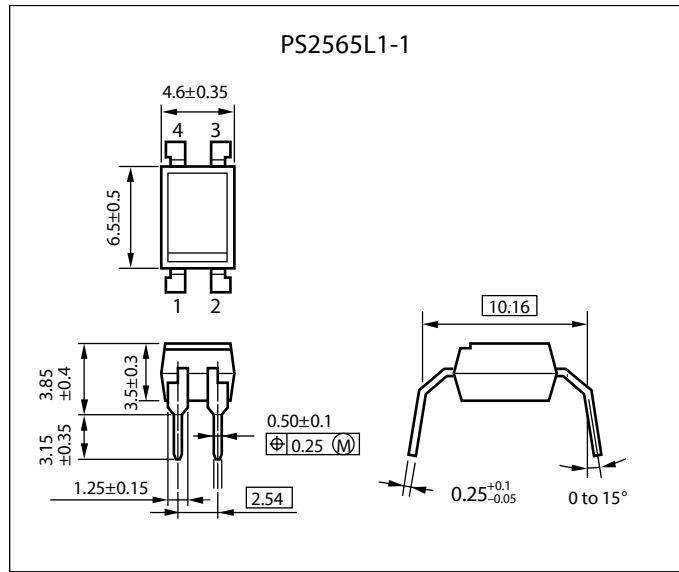

**Lead Bending Type For Surface Mount**

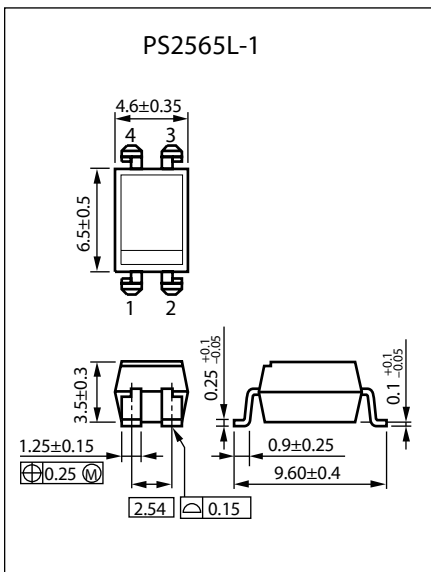

**Wide Lead Bending Type For Surface Mount**

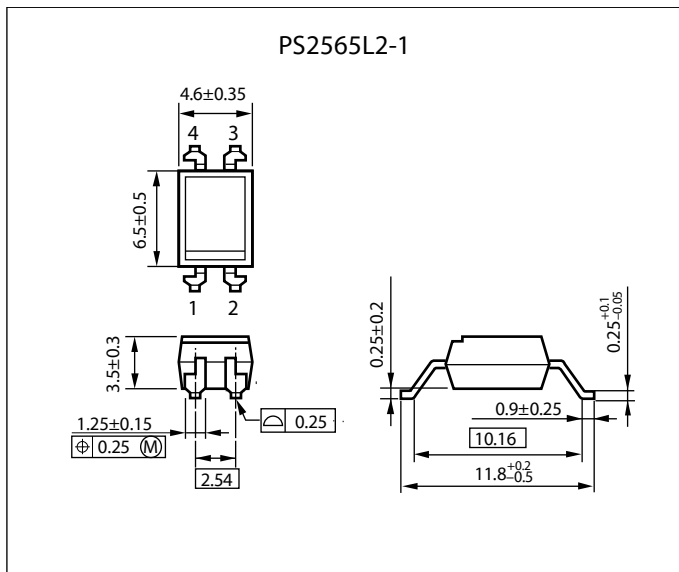

Weight ( 4-pin DIP ) : 0.26 g (typ.)

**PHOTOCOUPLER CONSTRUCTION**

| Parameter                 | Unit (mm) |
|---------------------------|-----------|
| Air Distance (MIN.)       | 7         |
| Creepage Distance (MIN.)  | 7         |
| Isolation Distance (MIN.) | 0.4       |

## MARKING EXAMPLE

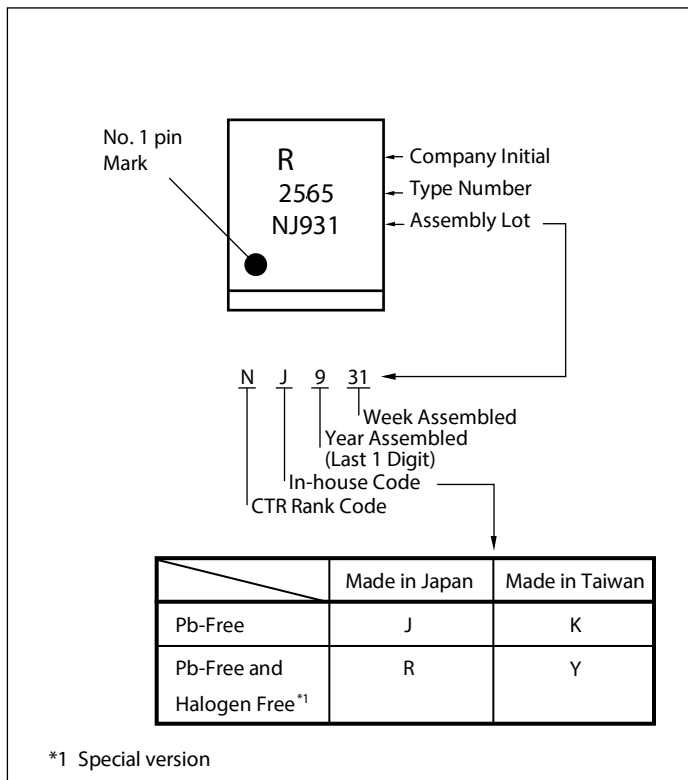

**ORDERING INFORMATION**

| Part Number     | Order Number       | Solder Plating Specification               | Packing Style         | Safety Standard Approval  | Application Part Number**    |            |
|-----------------|--------------------|--|-----------------------|---|------------------------------|------------|
| PS2565-1        | PS2565-1-A         | Pb-Free                                    | Magazine case 100 pcs | Standard products (UL, CSA, BSI, SEMKO, NEMKO, DEMKO, FIMKO approved) | PS2565-1                     |            |
| PS2565L-1       | PS2565L-1-A        |  |                       |   | PS2565L-1                    |            |
| PS2565L1-1      | PS2565L1-1-A       |  |                       |   | PS2565L1-1                   |            |
| PS2565L2-1      | PS2565L2-1-A       |  |                       |   | PS2565L2-1                   |            |
| PS2565L-1-F3    | PS2565L-1-F3-A     |  |                       |   | Embossed Tape 2 000 pcs/reel | PS2565L-1  |
| PS2565L2-1-F3   | PS2565L2-1-F3-A    |  |                       |   | Embossed Tape 2 000 pcs/reel | PS2565L2-1 |
| PS2565-1-V      | PS2565-1-V-A       |  | Magazine case 100 pcs | UL, CSA, BSI, SEMKO, NEMKO, FIMKO, DEMKO, DIN EN 60747-5-5 approved   | PS2565-1                     |            |
| PS2565L-1-V     | PS2565L-1-V-A      |  |                       |   | PS2565L-1                    |            |
| PS2565L1-1-V    | PS2565L1-1-V-A     |  |                       |   | PS2565L1-1                   |            |
| PS2565L2-1-V    | PS2565L2-1-V-A     |  |                       |   | PS2565L2-1                   |            |
| PS2565L-1-V-F3  | PS2565L-1-V-F3-A   |  |                       |   | Embossed Tape 2 000 pcs/reel | PS2565L-1  |
| PS2565L2-1-V-F3 | PS2565L2-1-V-F3-A  |  |                       |   | Embossed Tape 2 000 pcs/reel | PS2565L2-1 |
| PS2565-1        | PS2565-1Y-A        | Special version (Pb-Free and Halogen Free) | Magazine case 100 pcs | Standard products (UL, CSA, BSI, SEMKO, NEMKO, DEMKO, FIMKO approved) | PS2565-1                     |            |
| PS2565L-1       | PS2565L-1Y-A       |  |                       |   | PS2565L-1                    |            |
| PS2565L1-1      | PS2565L1-1Y-A      |  |                       |   | PS2565L1-1                   |            |
| PS2565L2-1      | PS2565L2-1Y-A      |  |                       |   | PS2565L2-1                   |            |
| PS2565L-1-F3    | PS2565L-1Y-F3-A    |  |                       |   | Embossed Tape 2 000 pcs/reel | PS2565L-1  |
| PS2565L2-1-F3   | PS2565L2-1Y-F3-A   |  |                       |   | Embossed Tape 2 000 pcs/reel | PS2565L2-1 |
| PS2565-1-V      | PS2565-1Y-V-A      |  | Magazine case 100 pcs | UL, CSA, BSI, SEMKO, NEMKO, FIMKO, DEMKO, DIN EN 60747-5-5 approved   | PS2565-1                     |            |
| PS2565L-1-V     | PS2565L-1Y-V-A     |  |                       |   | PS2565L-1                    |            |
| PS2565L1-1-V    | PS2565L1-1Y-V-A    |  |                       |   | PS2565L1-1                   |            |
| PS2565L2-1-V    | PS2565L2-1Y-V-A    |  |                       |   | PS2565L2-1                   |            |
| PS2565L-1-V-F3  | PS2565L-1Y-V-F3-A  |  |                       |   | Embossed Tape 2 000 pcs/reel | PS2565L-1  |
| PS2565L2-1-V-F3 | PS2565L2-1Y-V-F3-A |  |                       |   | Embossed Tape 2 000 pcs/reel | PS2565L2-1 |

Notes: \*1. For the application of the Safety Standard, following part number should be used.

**ABSOLUTE MAXIMUM RATINGS (T<sub>A</sub> = 25 °C, unless otherwise specified)**

| Parameter                     |                              | Symbol              | Ratings     | Unit    |
|-------------------------------|------------------------------|---------------------|-------------|---------|
| Diode                         | Forward Current (DC)         | I <sub>F</sub>      | 80          | mA      |
|                               | Power Dissipation Derating   | ΔP <sub>D</sub> /°C | 1.5         | mW/°C   |
|                               | Power Dissipation            | P <sub>D</sub>      | 150         | mW      |
|                               | Peak Forward Current*1       | I <sub>FP</sub>     | 1           | A       |
| Transistor                    | Collector to Emitter Voltage | V <sub>CEO</sub>    | 80          | V       |
|                               | Emitter to Collector Voltage | V <sub>ECO</sub>    | 7           | V       |
|                               | Collector Current            | I <sub>C</sub>      | 50          | mA      |
|                               | Power Dissipation Derating   | ΔP <sub>C</sub> /°C | 1.5         | mW/°C   |
|                               | Power Dissipation            | P <sub>C</sub>      | 150         | mW      |
| Isolation Voltage*2           |                              | BV                  | 5 000       | Vr.m.s. |
| Operating Ambient Temperature |                              | T <sub>A</sub>      | -55 to +100 | °C      |
| Storage Temperature           |                              | T <sub>stg</sub>    | -55 to +150 | °C      |

Note: \*1. PW = 100 μs, Duty Cycle = 1 %

\*2. AC voltage for 1 minute at T<sub>A</sub> = 25 °C, RH = 60 % between input and output.  
Pins 1-2 shorted together, 3-4 shorted together.

**ELECTRICAL CHARACTERISTICS (T<sub>A</sub> = 25 °C)**

|            | Parameter  | Symbol               | Conditions  | MIN.             | TYP. | MAX. | Unit |
|------------|--|----------------------|---|------------------|------|------|------|
| Diode      | Forward Voltage  | V <sub>F</sub>       | I <sub>F</sub> = ±10 mA   |                  | 1.17 | 1.4  | V    |
|            | Terminal Capacitance                                     | C <sub>t</sub>       | V = 0 V, f = 1.0 MHz  |                  | 100  |      | pF   |
| Transistor | Collector to Emitter Dark Current                        | I <sub>CEO</sub>     | V <sub>CE</sub> = 80 V, I <sub>F</sub> = 0 mA                         |                  |      | 100  | nA   |
| Coupled    | Current Transfer Ratio (I <sub>c</sub> /I <sub>F</sub> ) | CTR                  | I <sub>F</sub> = ±5 mA, V <sub>CE</sub> = 5 V                         | 80               | 200  | 400  | %    |
|            | CTR Ratio*1  | CTR1/<br>CTR2        | I <sub>F</sub> = 5 mA, V <sub>CE</sub> = 5 V                          | 0.3              | 1.0  | 3.0  |      |
|            | Collector Saturation Voltage                             | V <sub>CE(sat)</sub> | I <sub>F</sub> = ±10 mA, I <sub>c</sub> = 2 mA                        |                  |      | 0.3  | V    |
|            | Isolation Resistance                                     | R <sub>I-O</sub>     | V <sub>I-O</sub> = 1.0 kV <sub>DC</sub>                               | 10 <sup>11</sup> |      |      | Ω    |
|            | Isolation Capacitance                                    | C <sub>I-O</sub>     | V = 0 V, f = 1.0 MHz  |                  | 0.5  |      | pF   |
|            | Rise Time*2  | t <sub>r</sub>       | V <sub>CC</sub> = 10 V, I <sub>c</sub> = 2 mA, R <sub>L</sub> = 100 Ω |                  | 3    |      | μs   |
|            | Fall Time*2  | t <sub>f</sub>       |   |                  | 5    |      |      |

Note: \*1. CTR1 = I<sub>c1</sub>/I<sub>F1</sub>, CTR2 = I<sub>c2</sub>/I<sub>F2</sub>

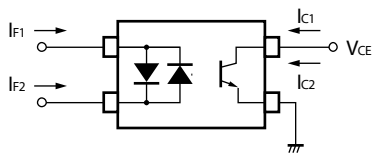

**\*2. Test Circuit for Switching Time**

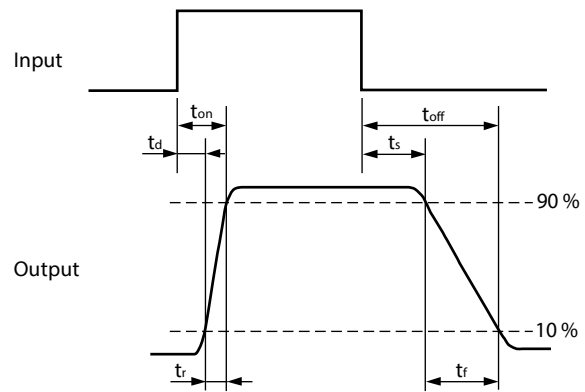
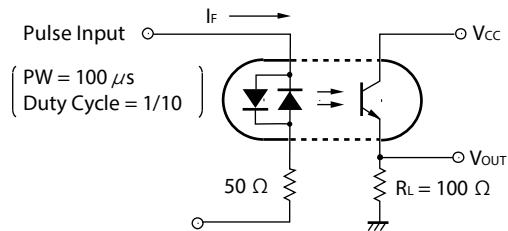

**TYPICAL CHARACTERISTICS (T<sub>A</sub> = 25 °C, unless otherwise specified)**

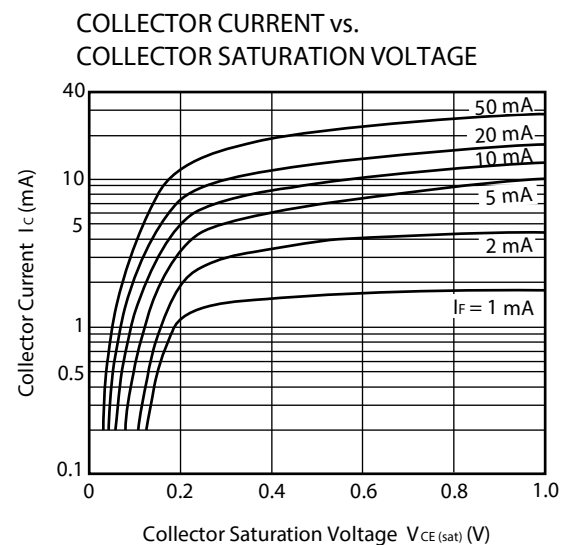
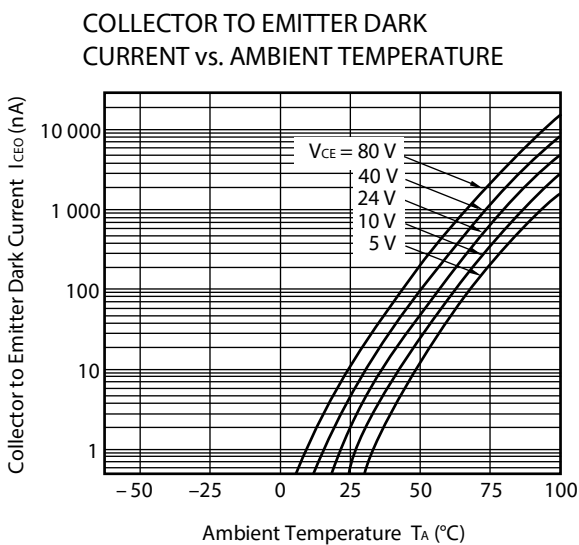
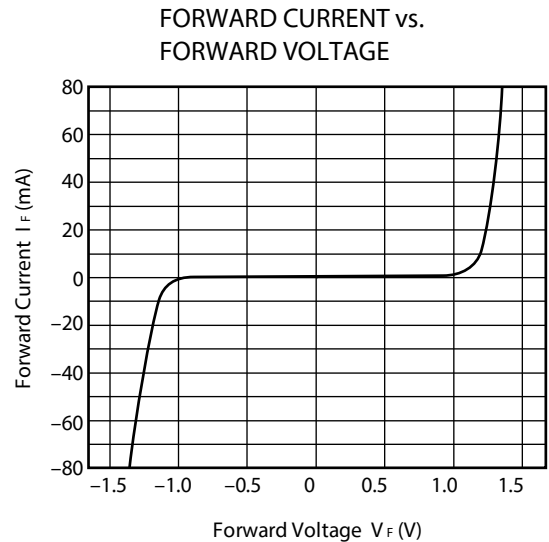
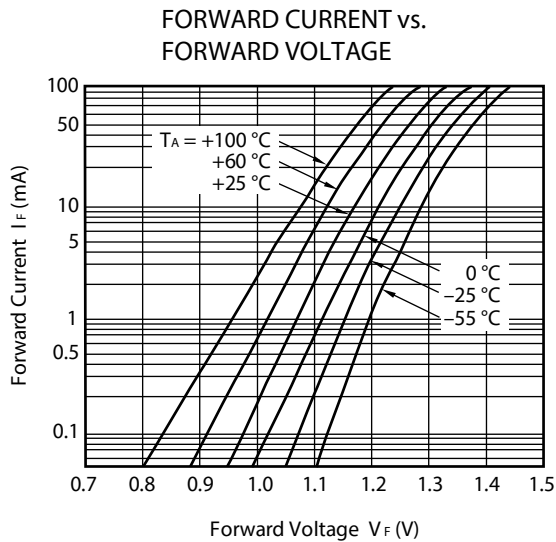
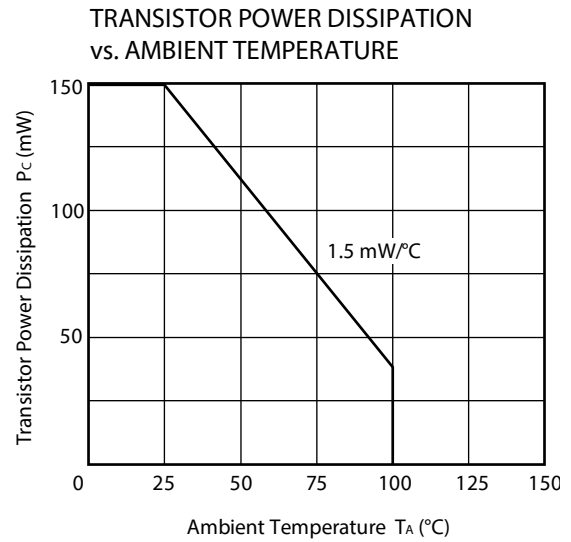
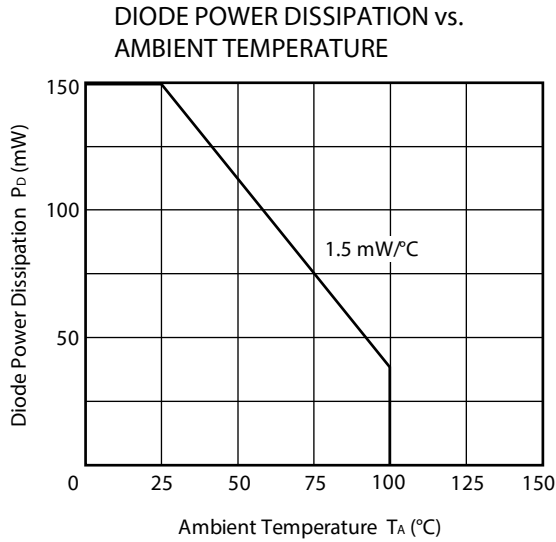

**Remark** The graphs indicate nominal characteristics.

COLLECTOR CURRENT vs. COLLECTOR TO EMITTER VOLTAGE

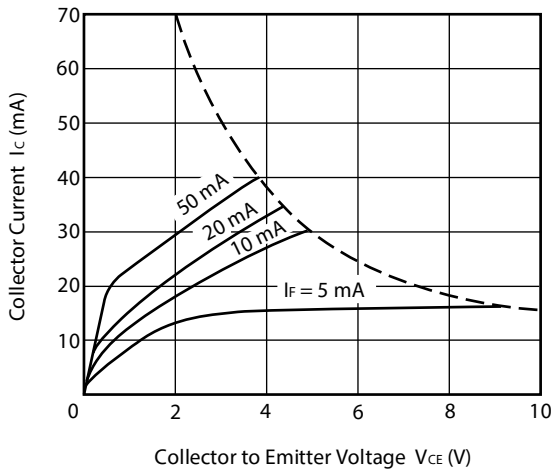

NORMALIZED CURRENT TRANSFER RATIO vs. AMBIENT TEMPERATURE

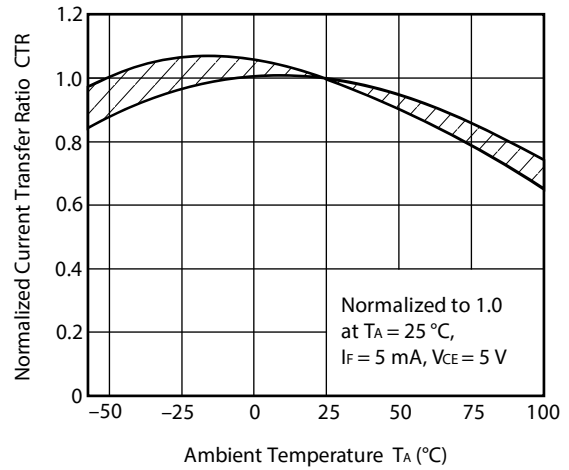

CURRENT TRANSFER RATIO vs. FORWARD CURRENT

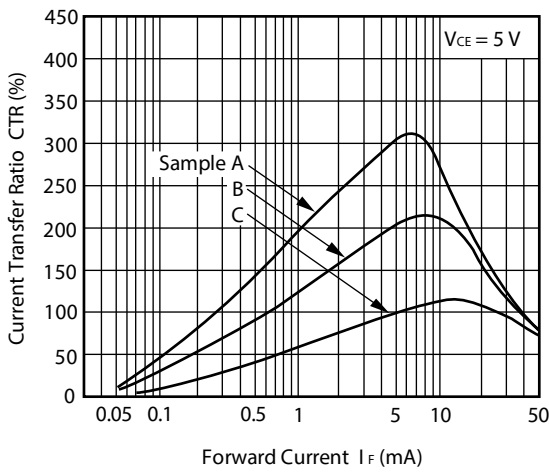

SWITCHING TIME vs. LOAD RESISTANCE

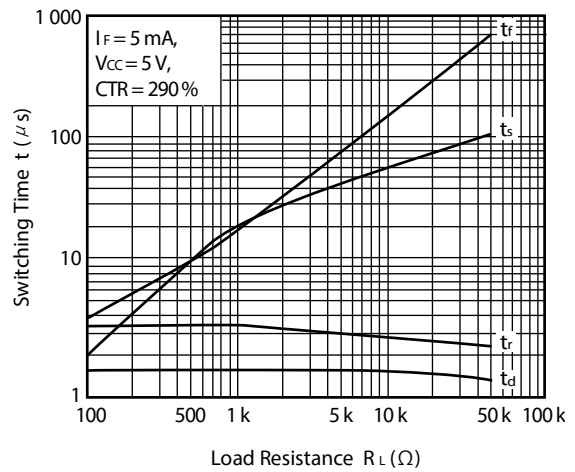

SWITCHING TIME vs. LOAD RESISTANCE

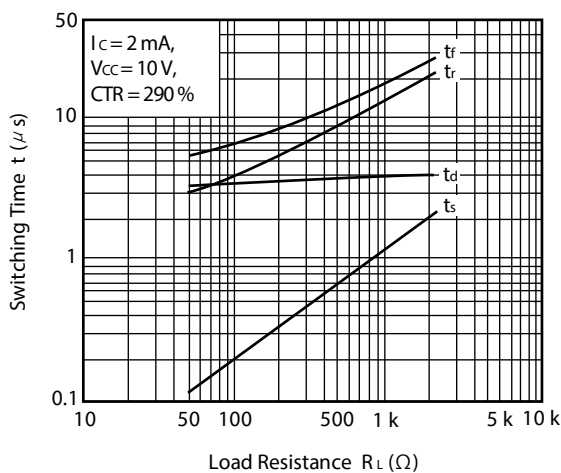

FREQUENCY RESPONSE

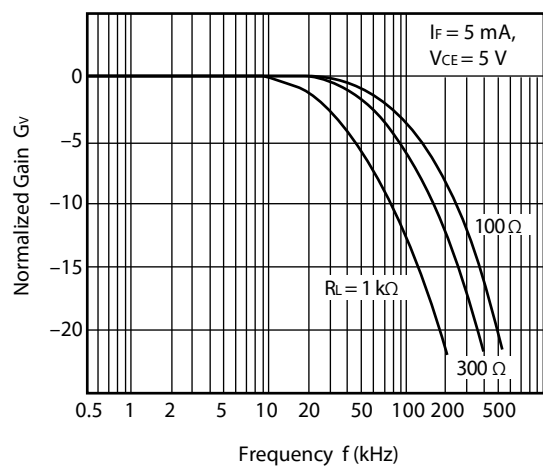

**Remark** The graphs indicate nominal characteristics.



**TAPING SPECIFICATIONS (UNIT: mm)**

Taping Direction

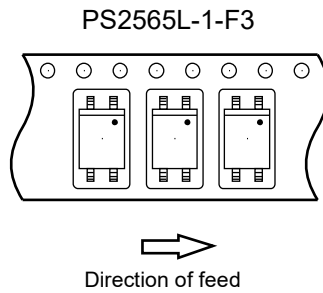

Outline and Dimensions (Tape)

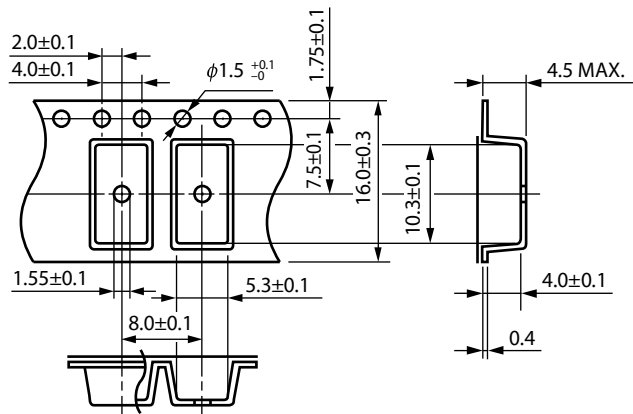

Outline and Dimensions (Reel)

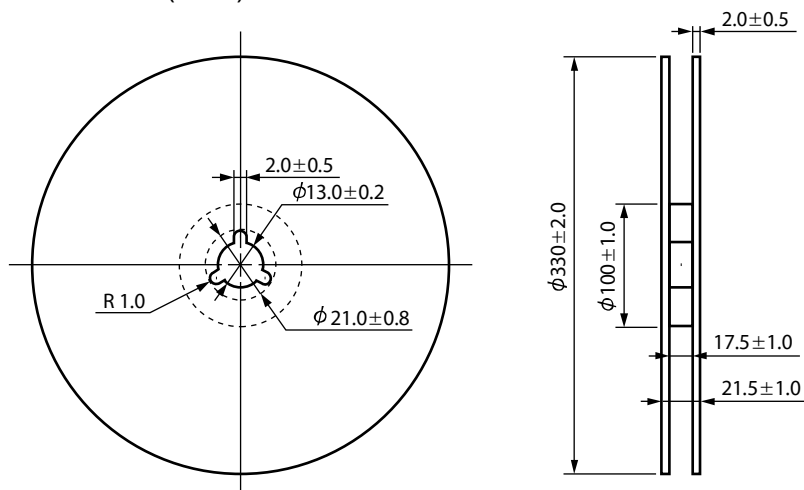

Packing: 2 000 pcs/reel

**TAPING SPECIFICATIONS (UNIT: mm)**

Taping Direction

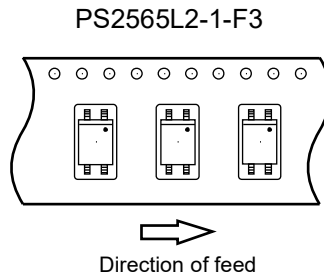

Outline and Dimensions (Tape)

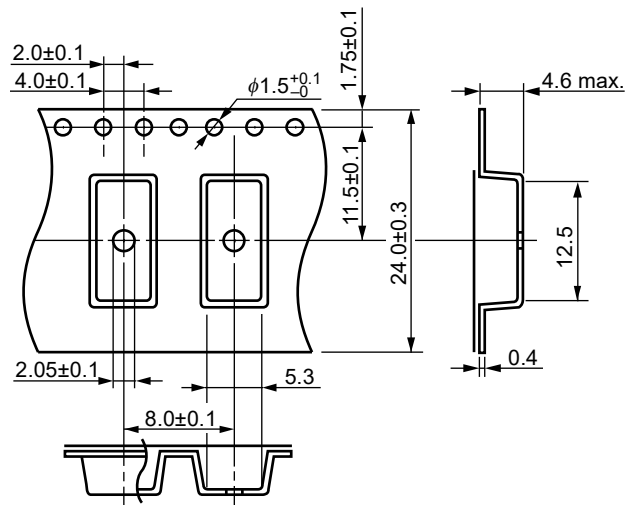

Outline and Dimensions (Reel)

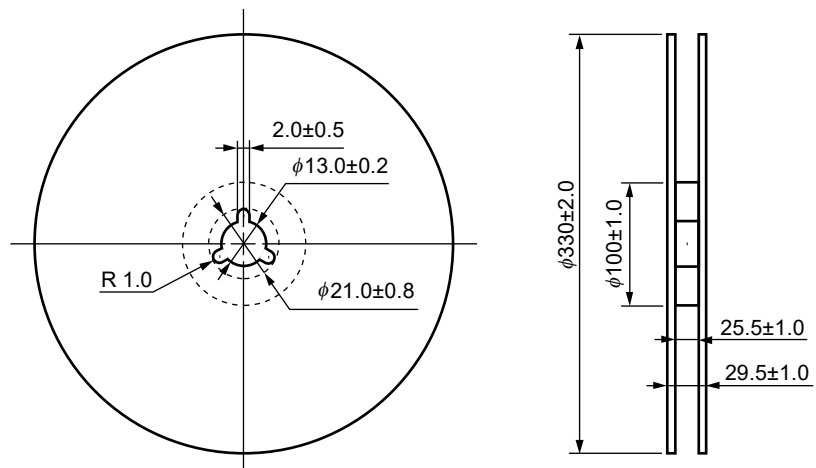

Packing: 2 000 pcs/reel

**RECOMMENDED MOUNT PAD DIMENSIONS (UNIT: mm)**

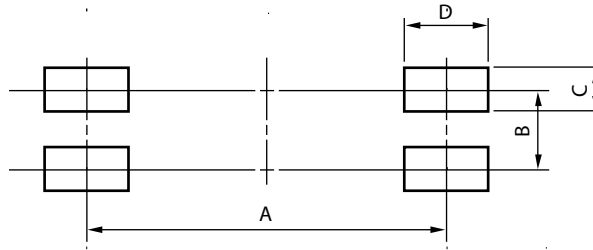
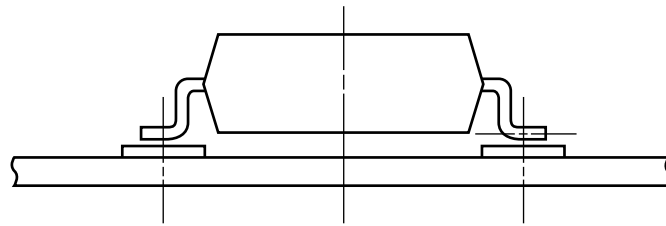

| Part Number | Lead Bending                             | A    | B    | C   | D   |
|-------------|--|------|------|-----|-----|
| PS2565L     | Lead Bending Type For Surface Mount      | 8.2  | 2.54 | 1.7 | 2.2 |
| PS2565L2    | Wide Lead Bending Type For Surface Mount | 10.2 | 2.54 | 1.7 | 2.2 |

**Remark** All dimensions in this figure must be evaluated before use.

## NOTES ON HANDLING

### 1. Recommended soldering conditions

#### (1) Infrared reflow soldering

- Peak reflow temperature 260 °C or below (package surface temperature)
- Time of peak reflow temperature 10 seconds or less
- Time of temperature higher than 220°C 60 seconds or less
- Time to preheat temperature from 120 to 180°C 120 ± 30 s
- Number of reflows Three
- Flux Rosin flux containing small amount of chlorine  
(The flux with a maximum chlorine content of 0.2 Wt% is recommended.)

Recommended Temperature Profile of Infrared Reflow

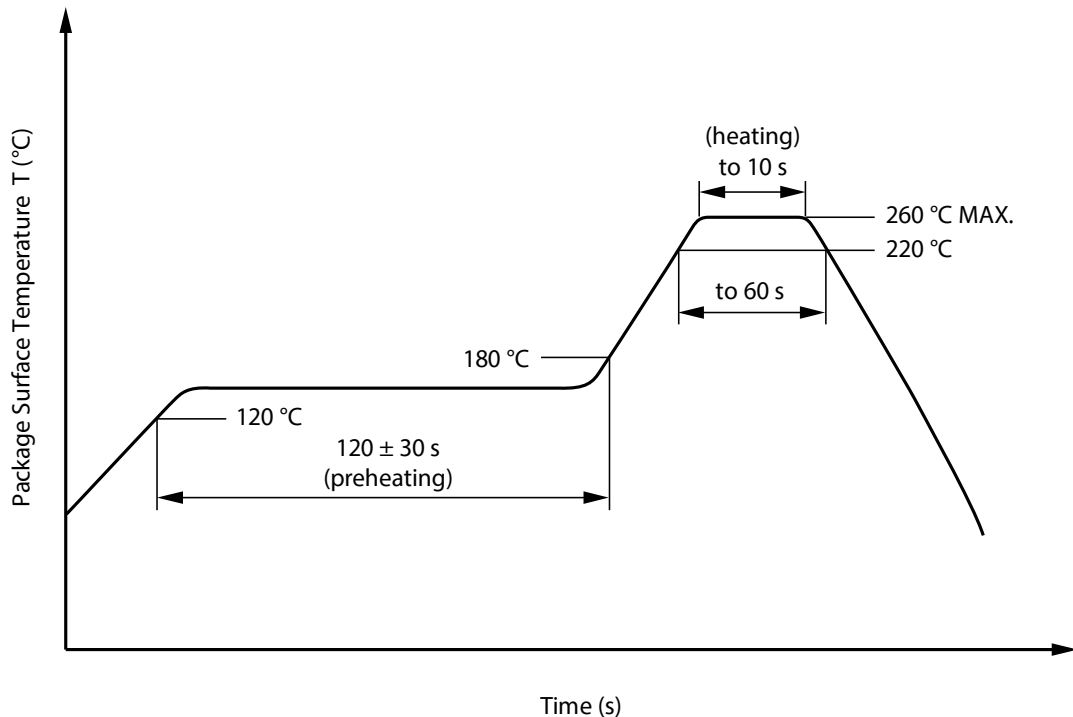

#### (2) Wave soldering

- Temperature 260 °C or below (molten solder temperature)
- Time 10 seconds or less
- Preheating conditions 120 °C or below (package surface temperature)
- Number of times One (Allowed to be dipped in solder including plastic mold portion.)
- Flux Rosin flux containing small amount of chlorine (The flux with a maximum chlorine content of 0.2 Wt% is recommended.)

#### (3) Soldering by Soldering Iron

- Peak Temperature (lead part temperature) 350 °C or below
- Time (each pins) 3 seconds or less
- Flux Rosin flux containing small amount of chlorine  
(The flux with a maximum chlorine content of 0.2 Wt% is recommended.)

(a) Soldering of leads should be made at the point 1.5 to 2.0 mm from the root of the lead

(b) Please be sure that the temperature of the package would not be heated over 100 °C

#### (4) Cautions

- Flux Cleaning  
Avoid cleaning with Freon based or halogen-based (chlorinated etc.) solvents.
- Do not use fixing agents or coatings containing halogen-based substances.

2. Cautions regarding noise

Be aware that when voltage is applied suddenly between the photocoupler's input and output or between collector-emitters at startup, the output transistor may enter the on state, even if the voltage is within the absolute maximum ratings.

3. Measurement conditions of current transfer ratios (CTR), which differ according to photocoupler

Check the setting values before use, since the forward current conditions at CTR measurement differ according to product.

When using products other than at the specified forward current, the characteristics curves may differ from the standard curves due to CTR value variations or the like. Therefore, check the characteristics under the actual operating conditions and thoroughly take variations or the like into consideration before use.

## **USAGE CAUTIONS**

1. Protect against static electricity when handling.
2. Avoid storage at a high temperature and high humidity.
3. Avoid cleaning with Freon based or halogen-based (chlorinated etc.) solvents.
4. Do not use fixing agents or coatings containing halogen-based substances.

**SPECIFICATION OF VDE MARKS LICENSE DOCUMENT**

| Parameter  | Symbol  | Rating                      | Unit                       |
|--|---|-----------------------------|----------------------------|
| Climatic test class (IEC 60068-1/DIN EN 60068-1)   |   | 55/100/21                   |                            |
| Dielectric strength<br>maximum operating isolation voltage<br>Test voltage (partial discharge test, procedure a for type test and random test)<br>$U_{pr} = 1.6 \times U_{IORM}, P_d < 5 \text{ pC}$   | $U_{IORM}$<br>$U_{pr}$                          | 890<br>1 424                | $V_{peak}$<br>$V_{peak}$   |
| Test voltage (partial discharge test, procedure b for all devices)<br>$U_{pr} = 1.875 \times U_{IORM}, P_d < 5 \text{ pC}$   | $U_{pr}$  | 1 669                       | $V_{peak}$                 |
| Highest permissible overvoltage  | $U_{IOTM}$                                      | 8 000                       | $V_{peak}$                 |
| Degree of pollution (IEC 60664-1/DIN EN 60664-1 (VDE 0110-1))  |   | 2                           |                            |
| Comparative tracking index (IEC 60112/DIN EN 60112 (VDE 0303-11))  | CTI   | 175                         |                            |
| Material group (IEC 60664-1/DIN EN 60664-1 (VDE 0110-1))   |   | III a                       |                            |
| Storage temperature range  | $T_{stg}$                                       | -55 to +150                 | °C                         |
| Operating temperature range  | $T_A$   | -55 to +100                 | °C                         |
| Isolation resistance, minimum value<br>$V_{IO} = 500 \text{ V dc at } T_A = 25^\circ\text{C}$<br>$V_{IO} = 500 \text{ V dc at } T_A \text{ MAX. at least } 100^\circ\text{C}$  | Ris MIN.<br>Ris MIN.                            | $10^{12}$<br>$10^{11}$      | $\Omega$<br>$\Omega$       |
| Safety maximum ratings (maximum permissible in case of fault, see thermal derating curve)<br>Package temperature<br>Current (input current $I_F$ , $\Psi_i = 0$ )<br>Power (output or total power dissipation)<br>Isolation resistance<br>$V_{IO} = 500 \text{ V dc at } T_A = T_{si}$ | $T_{si}$<br>$I_{si}$<br>$\Psi_{si}$<br>Ris MIN. | 175<br>400<br>700<br>$10^9$ | °C<br>mA<br>mW<br>$\Omega$ |

Dependence of maximum safety ratings with package temperature

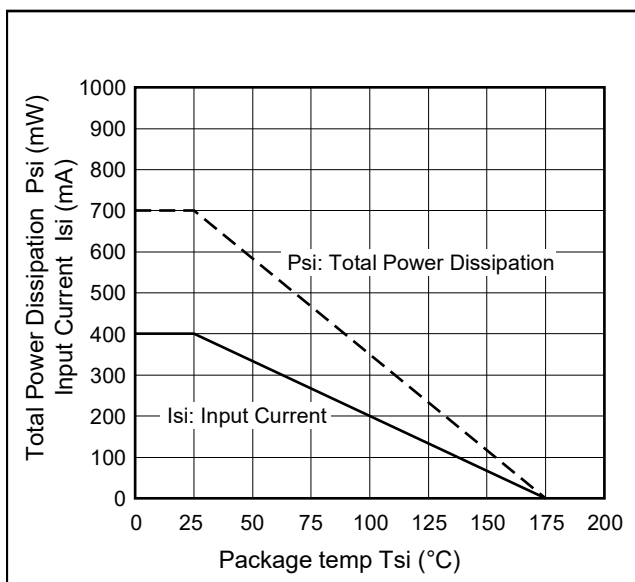

Method a) Destructive Test, Type and Sample Test

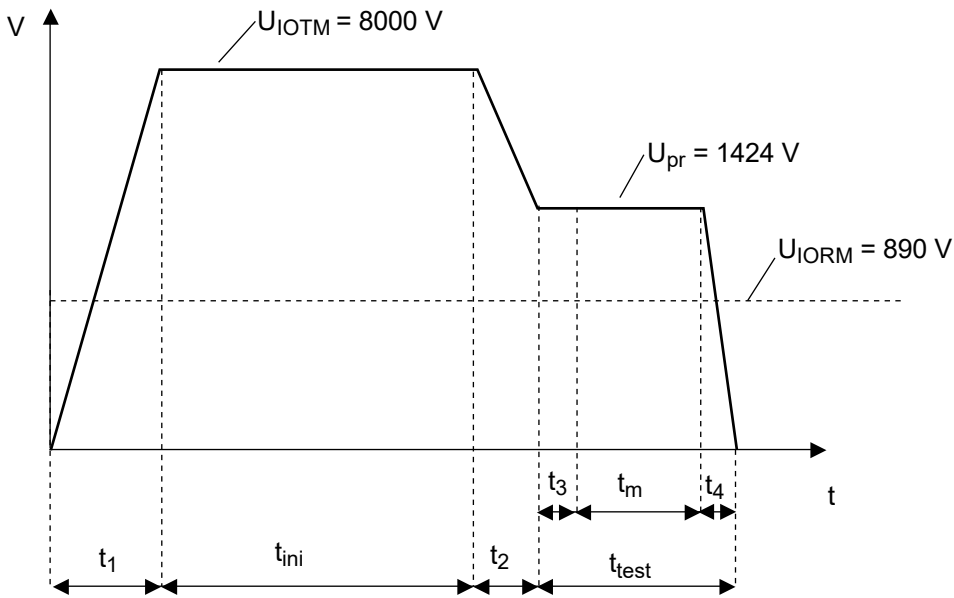

$t_1, t_2 = 1\text{ to }10\text{ sec}$   
 $t_3, t_4 = 1\text{ sec}$   
 $t_m(\text{PARTIAL DISCHARGE}) = 10\text{ sec}$   
 $t_{test} = 12\text{ sec}$   
 $t_{ini} = 60\text{ sec}$

Method b) Non-destructive Test, 100 % Production Test

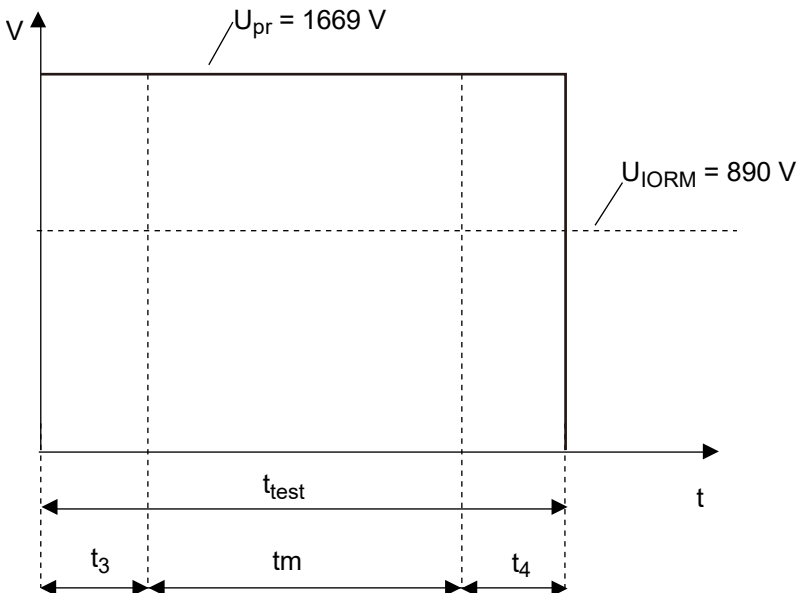

$t_3, t_4 = 0.1\text{ sec}$   
 $t_m(\text{PARTIAL DISCHARGE}) = 1.0\text{ sec}$   
 $t_{test} = 1.2\text{ sec}$

|                |               |  |
|----------------|---------------|--|
| <b>Caution</b> | GaAs Products | <p>This product uses gallium arsenide (GaAs). GaAs vapor and powder are hazardous to human health if inhaled or ingested, so please observe the following points.</p> <ul style="list-style-type: none"><li>• Follow related laws and ordinances when disposing of the product. If there are no applicable laws and/or ordinances, dispose of the product as recommended below.<ol style="list-style-type: none"><li>1. Commission a disposal company able to (with a license to) collect, transport and dispose of materials that contain arsenic and other such industrial waste materials.</li><li>2. Exclude the product from general industrial waste and household garbage, and ensure that the product is controlled (as industrial waste subject to special control) up until final disposal.</li></ol></li><li>• Do not burn, destroy, cut, crush, or chemically dissolve the product.</li><li>• Do not lick the product or in any way allow it to enter the mouth.</li></ul> |
|----------------|---------------|--|

All trademarks and registered trademarks are the property of their respective owners.