

# PS8302L, PS8302L2

1 Mbps, HIGH CMR, ANALOG OUTPUT TYPE  
8 mm CREEPAGE 6-PIN SDIP PHOTOCOUPLER

R08DS0253EJ0100  
Rev.1.00  
Nov 4, 2021

## DESCRIPTION

The PS8302L and PS8302L2 are optical coupled isolators containing an AlGaAs LED on the input side and a PIN photodiode and a high-speed amplifier transistor on the output side on one chip.

The PS8302L and PS8302L2 are designed specifically for high supply voltage and high common mode transient immunity (CMR).

The PS8302L and PS8302L2 are in 6-pin plastic SDIP (Shrink Dual In-line Package). The PS8302L2 has 8 mm creepage distance and is half size of 8-pin DIP.

The PS8302L is lead bending type (Gull-wing) for surface mounting.

The PS8302L2 is lead bending type for long creepage distance (Gull-wing) for surface mount.

## FEATURES

- High common mode transient immunity ( $CM_H, CM_L = \pm 15 \text{ kV}/\mu\text{s MIN.}$ )
- Half size of 8-pin DIP
- Long creepage distance (8 mm MIN. : PS8302L2)
- High supply voltage ( $V_{CC} = 35 \text{ V}$ )
- High isolation voltage ( $BV = 5\,000 \text{ Vr.m.s.}$ )
- High-speed response ( $t_{PHL} = 0.8 \mu\text{s MAX.}, t_{PLH} = 0.8 \mu\text{s MAX.}$ )
- Pb-Free product
- Safety standards
  - UL approved: UL1577, Double protection
  - CSA approved: CAN/CSA-C22.2 No.62368-1, Reinforced insulation
  - VDE approved: DIN EN 60747-5-5 (Option)

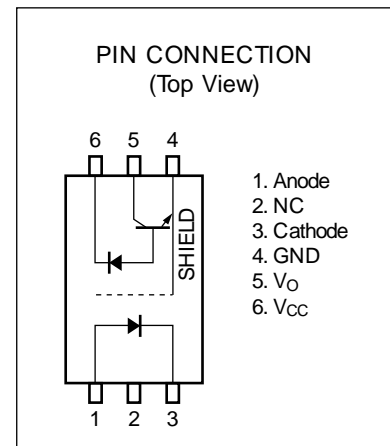

## APPLICATIONS

- Computer and peripheral manufactures
- General purpose inverter
- Substitutions for relays and pulse transformers
- Power supply

Start of mass production  
Mar.2008

**PACKAGE DIMENSIONS (UNIT: mm)**

Lead Bending Type (Gull-wing) For Surface Mount

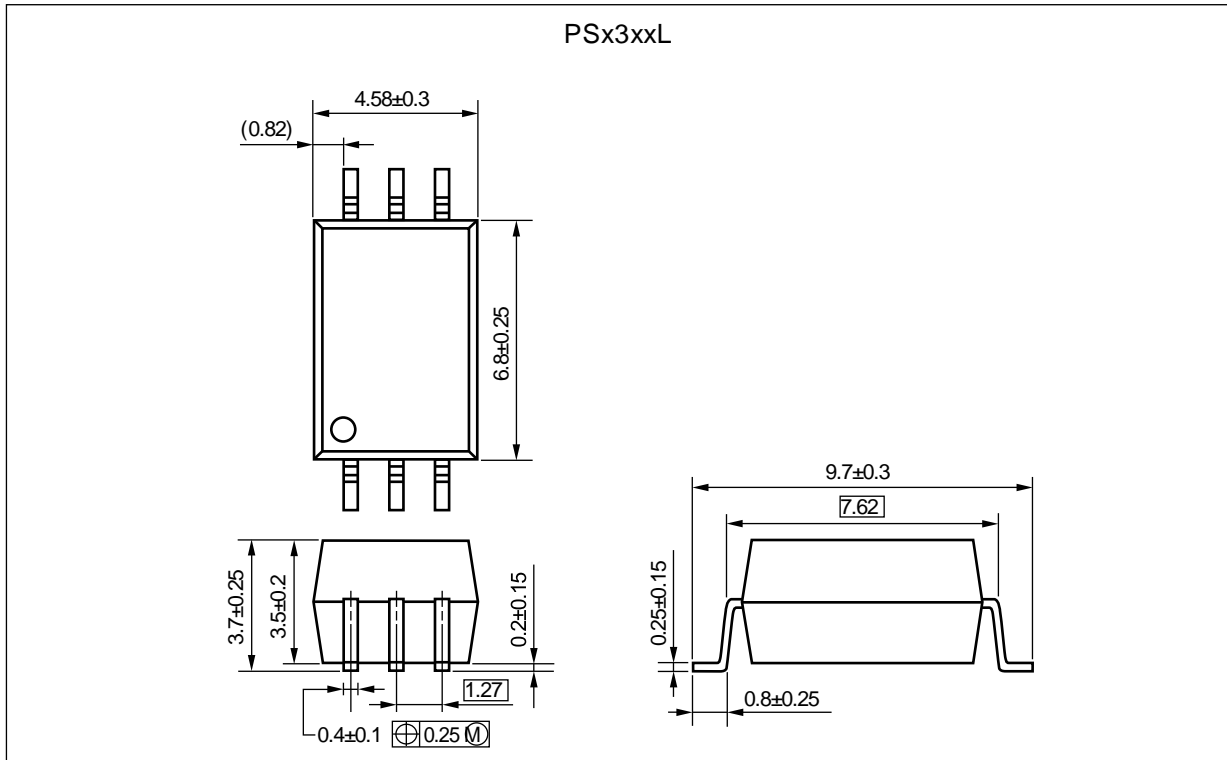

Lead Bending Type (Gull-wing) For Long Creepage Distance (Surface Mount)

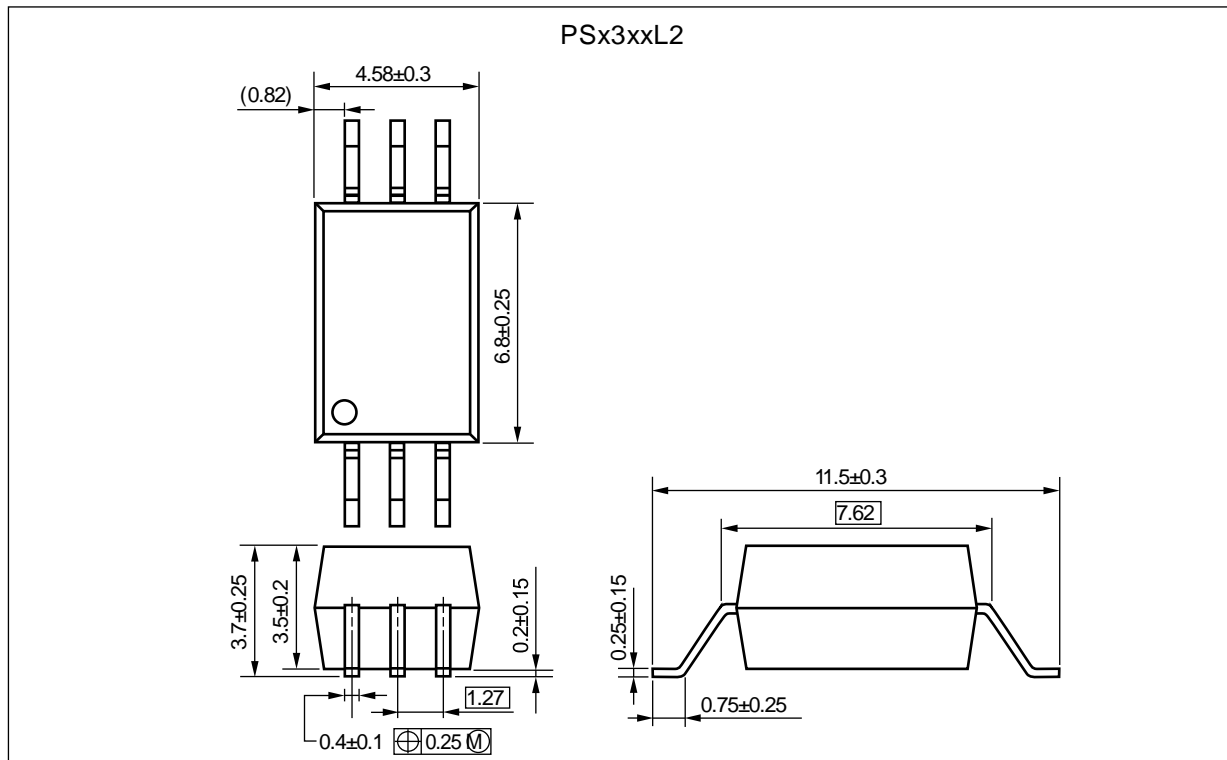

Weight: 0.27g (typ.)

**MARKING EXAMPLE**

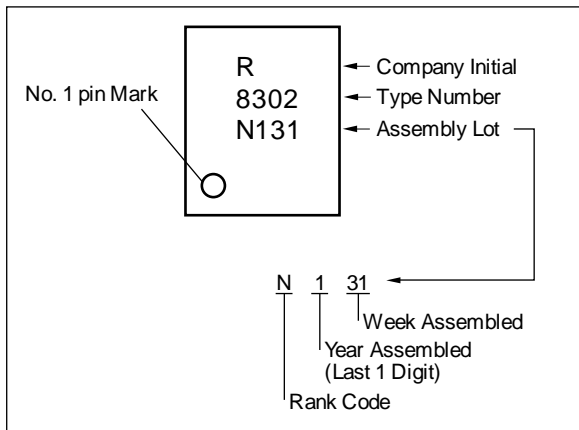

**PHOTOCOUPLER CONSTRUCTION**

Parameter	PS8302L	PS8302L2
Air Distance (MIN.)	7 mm	8 mm
Creepage Distance (MIN.)	7 mm	8 mm
Isolation Distance (MIN.)	0.4 mm	0.4 mm

**ORDERING INFORMATION**

Part Number	Order Number	Solder Plating Specification	Packing Style	Safety Standard Approval	Application Part Number <sup>*1</sup>
PS8302L	PS8302L-AX	Pb-Free (Ni/Pd/Au)	20 pcs (Tape 20 pcs cut)	Standard products (UL, CSA approved)	PS8302L
PS8302L-E3	PS8302L-E3-AX		Embossed Tape 2 000 pcs/reel		
PS8302L2	PS8302L2-AX		20 pcs (Tape 20 pcs cut)		PS8302L2
PS8302L2-E3	PS8302L2-E3-AX		Embossed Tape 2 000 pcs/reel		
PS8302L-V	PS8302L-V-AX		20 pcs (Tape 20 pcs cut)	UL, CSA, DIN EN60747-5-5 approved	PS8302L
PS8302L-V-E3	PS8302L-V-E3-AX		Embossed Tape 2 000 pcs/reel		
PS8302L2-V	PS8302L2-V-AX		20 pcs (Tape 20 pcs cut)		PS8302L2
PS8302L2-V-E3	PS8302L2-V-E3-AX		Embossed Tape 2 000 pcs/reel		

Notes\*: 1. For the application of the Safety Standard, following part number should be used.

**ABSOLUTE MAXIMUM RATINGS ( $T_A = 25\text{ }^\circ\text{C}$ , unless otherwise specified)**

Parameter		Symbol	Ratings	Unit
Diode	Forward Current *1	$I_F$	25	mA
	Reverse Voltage	$V_R$	5	V
Detector	Supply Voltage	$V_{CC}$	35	V
	Output Voltage	$V_o$	35	V
	Output Current	$I_o$	8	mA
	Power Dissipation *2	$P_C$	100	mW
Isolation Voltage *3		BV	5 000	Vr.m.s.
Operating Ambient Temperature		$T_A$	- 55 to +110	$^\circ\text{C}$
Storage Temperature		$T_{stg}$	- 55 to +125	$^\circ\text{C}$

- Notes\*: 1. Reduced to 0.3 mA/ $^\circ\text{C}$  at  $T_A = 70\text{ }^\circ\text{C}$  or more.  
 2. Reduced to 2.0 mW/ $^\circ\text{C}$  at  $T_A = 75\text{ }^\circ\text{C}$  or more  
 3. AC voltage for 1 minute at  $T_A = 25\text{ }^\circ\text{C}$ , RH = 60 % between input and output.  
 Pins 1-3 shorted together, 4-6 shorted together.

**ELECTRICAL CHARACTERISTICS (T<sub>A</sub> = 25 °C, unless otherwise specified)**

Parameter		Symbol	Conditions	MIN.	TYP. <sup>1</sup>	MAX.	Unit
Diode	Forward Voltage	V <sub>F</sub>	I <sub>F</sub> = 16 mA		1.6	2.0	V
	Reverse Current	I <sub>R</sub>	V <sub>R</sub> = 3 V			10	μA
	Forward Voltage Temperature Coefficient	ΔV <sub>F</sub> /ΔT <sub>A</sub>	I <sub>F</sub> = 16 mA		- 2.1		mV/°C
	Terminal Capacitance	C <sub>t</sub>	V = 0 V, f = 1 MHz		30		pF
Detector	High Level Output Current	I <sub>OH</sub> (1)	I <sub>F</sub> = 0 mA, V <sub>CC</sub> = V <sub>O</sub> = 5.5 V		3	500	nA
	High Level Output Current	I <sub>OH</sub> (2)	I <sub>F</sub> = 0 mA, V <sub>CC</sub> = V <sub>O</sub> = 35 V			100	μA
	Low Level Output Voltage	V <sub>OL</sub>	I <sub>F</sub> = 16 mA, V <sub>CC</sub> = 4.5 V, I <sub>O</sub> = 2.4 mA		0.15	0.4	V
	High Level Supply Current	I <sub>CC</sub> H	I <sub>F</sub> = 0 mA, V <sub>O</sub> = open, V <sub>CC</sub> = 35 V		0.01	1	μA
	Low Level Supply Current	I <sub>CC</sub> L	I <sub>F</sub> = 16 mA, V <sub>O</sub> = open, V <sub>CC</sub> = 35 V		150		
Coupled	Current Transfer Ratio	CTR	I <sub>F</sub> = 16 mA, V <sub>CC</sub> = 4.5 V, V <sub>O</sub> = 0.4 V	15			%
	Input-Output Isolation Resistance	R <sub>I-O</sub>	V <sub>I-O</sub> = 1 kV <sub>DC</sub>	10 <sup>11</sup>			Ω
	Input-Output Isolation Capacitance	C <sub>I-O</sub>	V = 0 V, f = 1 MHz		0.7		pF
	Propagation Delay Time (H → L) <sup>2</sup>	t <sub>PHL</sub>	I <sub>F</sub> = 16 mA, V <sub>CC</sub> = 5 V, R <sub>L</sub> = 1.9 kΩ		0.3	0.8	μs
	Propagation Delay Time (L → H) <sup>2</sup>	t <sub>PLH</sub>			0.33	0.8	
	Common Mode Transient Immunity at High Level Output <sup>3</sup>	CM <sub>H</sub>	I <sub>F</sub> = 0 mA, V <sub>CC</sub> = 5 V, R <sub>L</sub> = 4.1 kΩ, V <sub>CM</sub> = 1.5 kV	15			kV/μs
	Common Mode Transient Immunity at Low Level Output <sup>3</sup>	CM <sub>L</sub>	I <sub>F</sub> = 16 mA, V <sub>CC</sub> = 5 V, R <sub>L</sub> = 4.1 kΩ, V <sub>CM</sub> = 1.5 kV	- 15			

Notes\*: 1. Typical values at  $T_A = 25\text{ }^\circ\text{C}$ .

2. Test circuit for propagation delay time

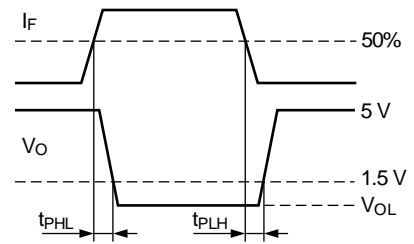
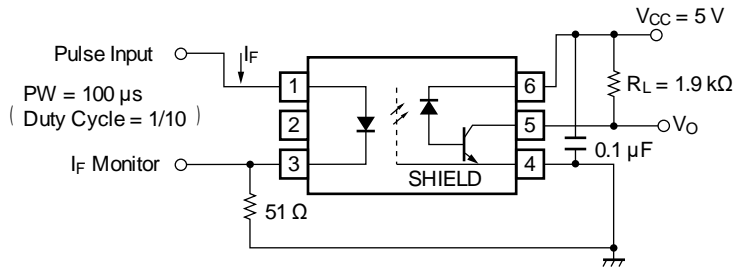

3. Test circuit for common mode transient immunity

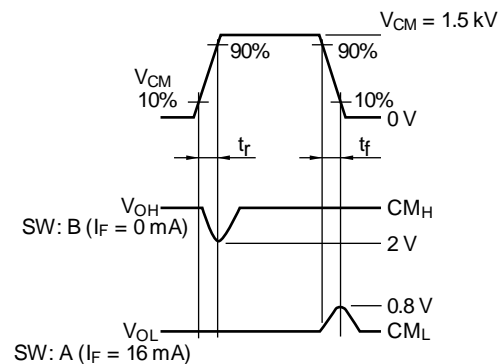
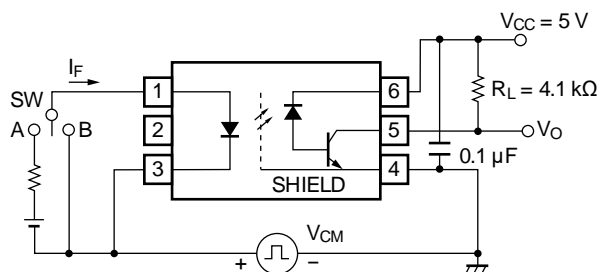

**USAGE CAUTIONS**

1. This product is weak for static electricity by designed with high-speed integrated circuit so protect against static electricity when handling.
2. By-pass capacitor of 0.1  $\mu\text{F}$  is used between  $V_{CC}$  and GND near device. Also, ensure that the distance between the leads of the photocoupler and capacitor is no more than 10 mm.
3. Pin 2 (which is an NC\*1 pin) can either be connected directly to the GND pin on the LED side or left open. Unconnected pins should not be used as a bypass for signals or for any other similar purpose because this may degrade the internal noise environment of the device.

\*1 NC: Not connected (No connection)

4. Avoid storage at a high temperature and high humidity.
5. Avoid cleaning with Freon based or halogen-based (chlorinated etc.) solvents.
6. Do not use fixing agents or coatings containing halogen-based substances.

TYPICAL CHARACTERISTICS (T<sub>A</sub> = 25 °C unless otherwise specified)

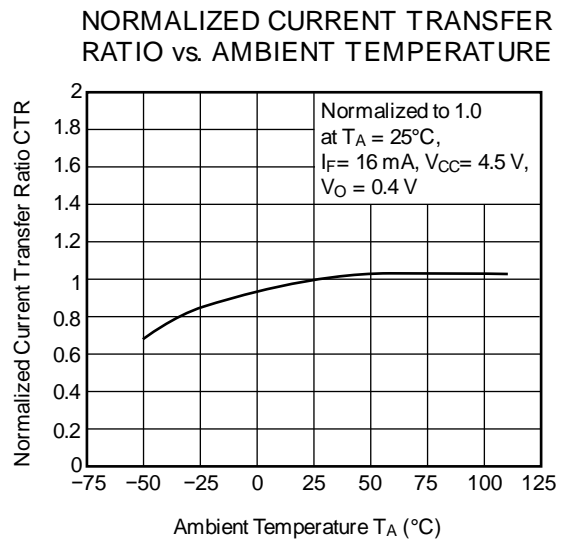
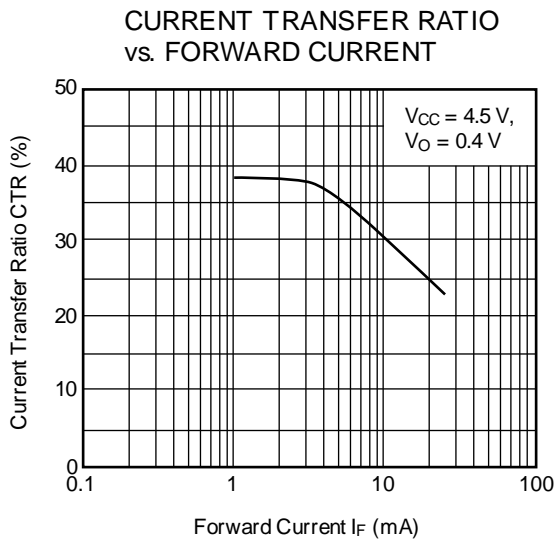
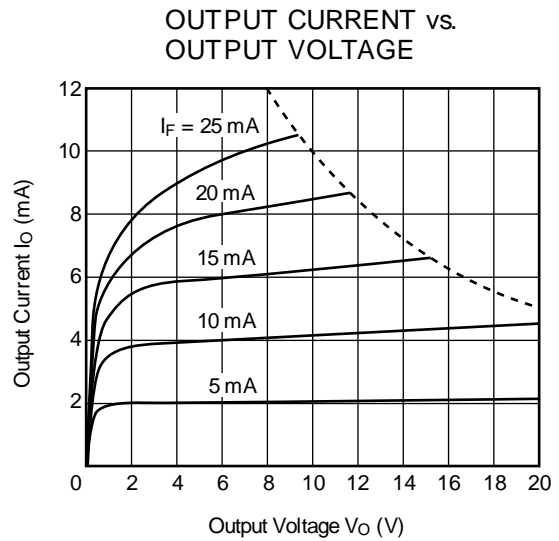
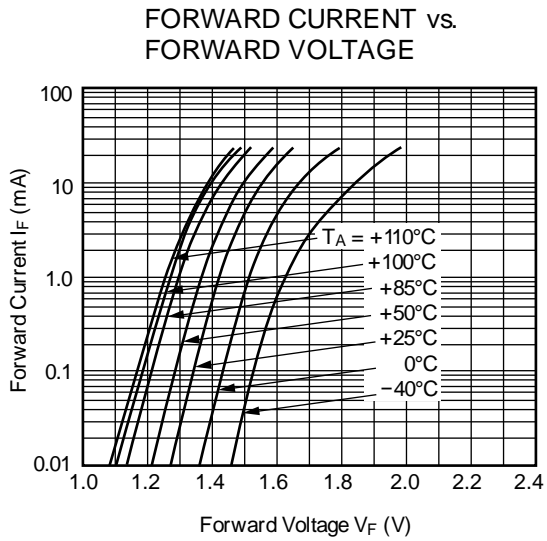
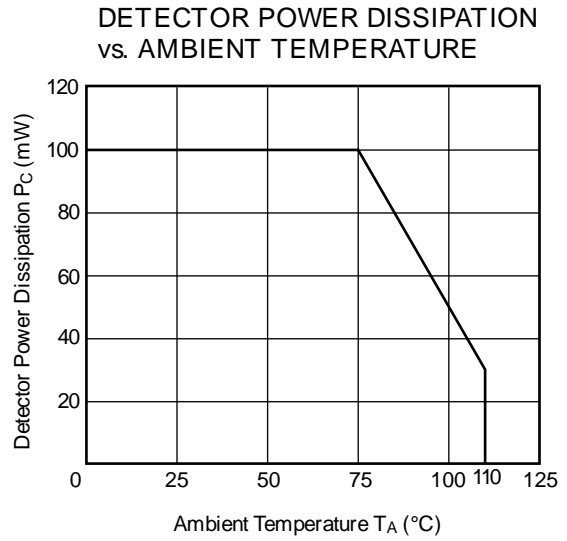
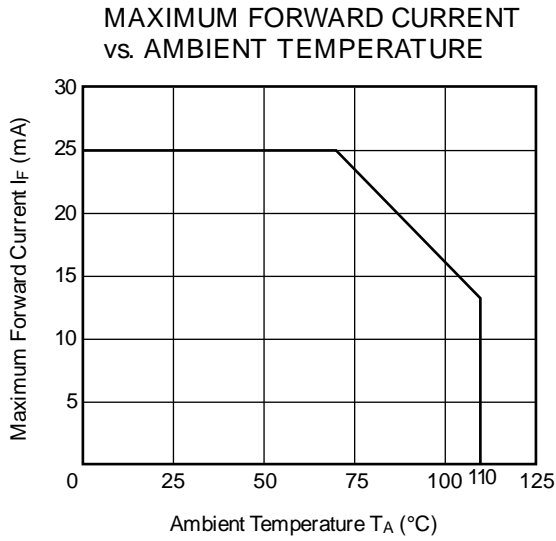

Remark The graphs indicate nominal characteristics.

OUTPUT VOLTAGE vs. FORWARD CURRENT

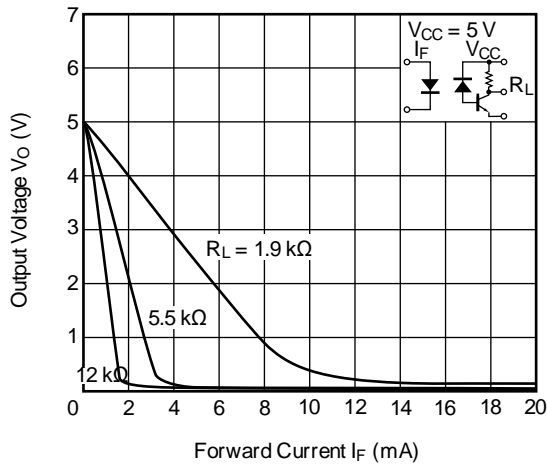

HIGH LEVEL OUTPUT CURRENT vs. AMBIENT TEMPERATURE

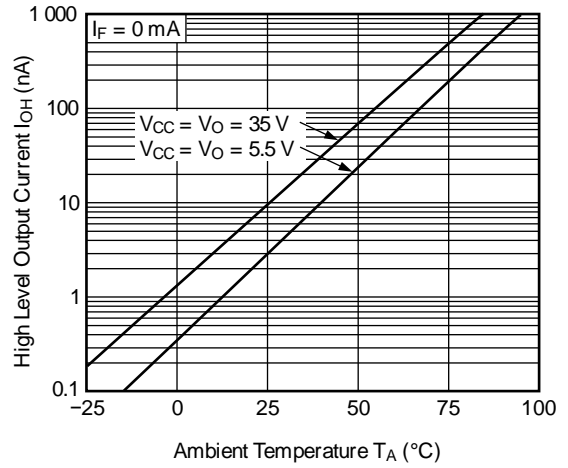

PROPAGATION DELAY TIME vs. LOAD RESISTANCE

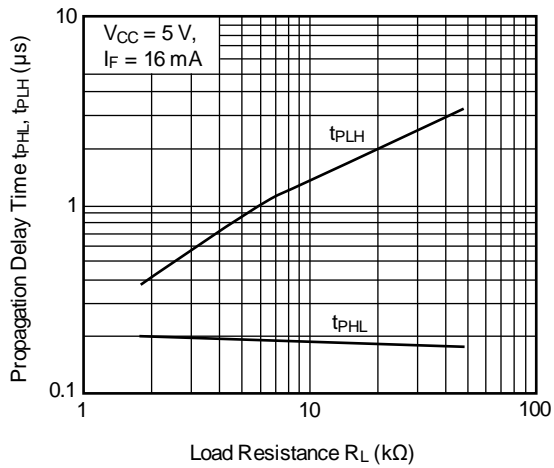

PROPAGATION DELAY TIME vs. AMBIENT TEMPERATURE

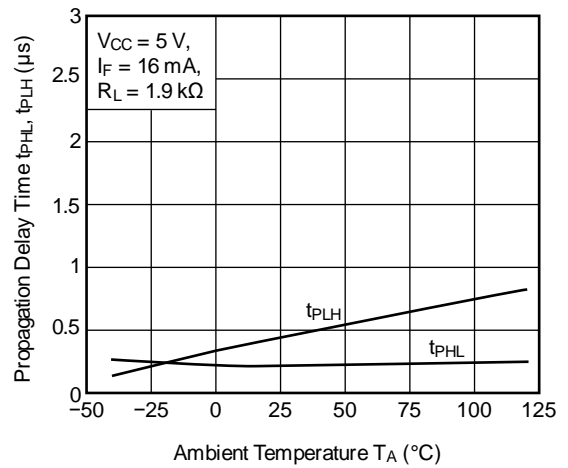

Remark The graphs indicate nominal characteristics.



TAPING SPECIFICATIONS (UNIT: mm)

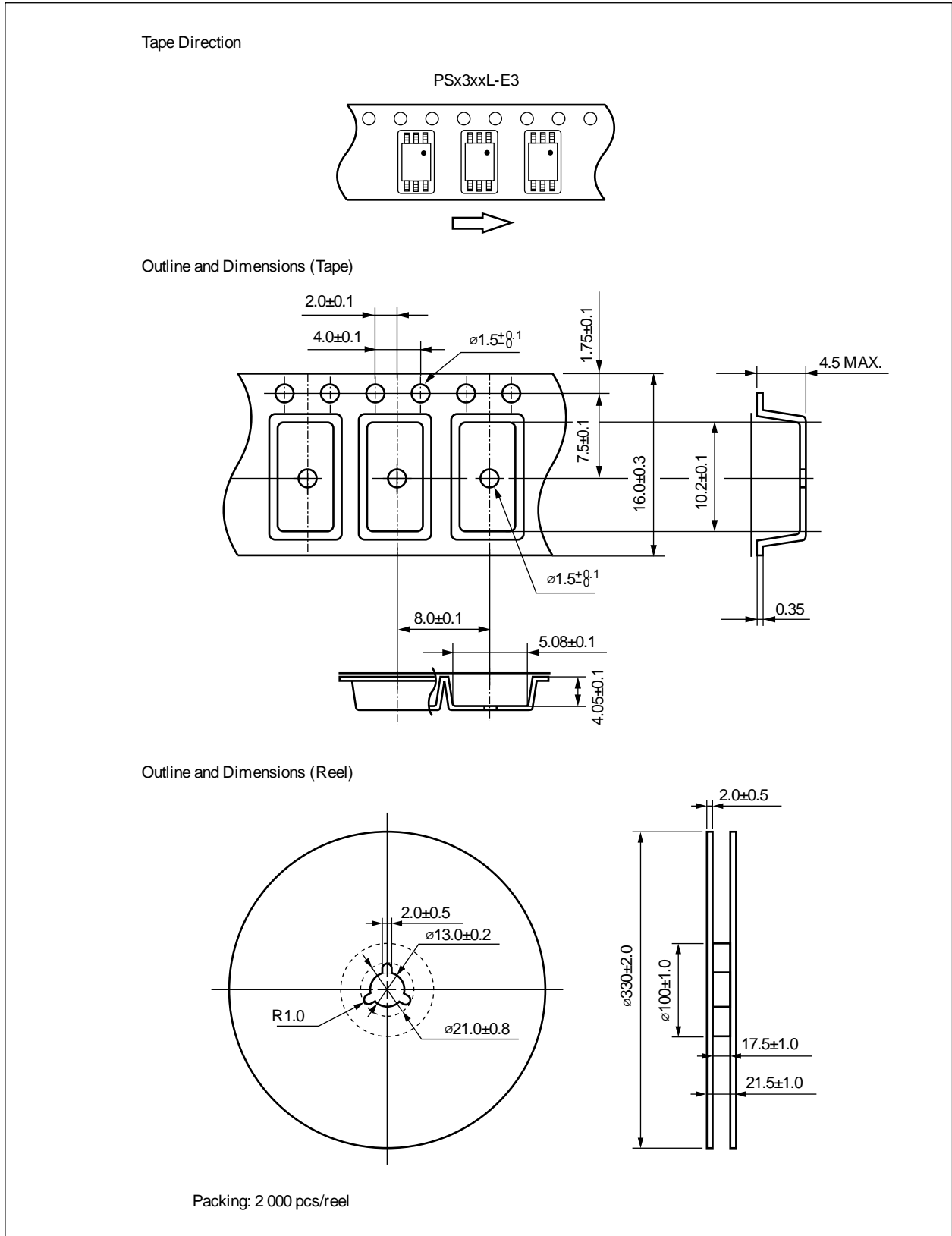

Tape Direction

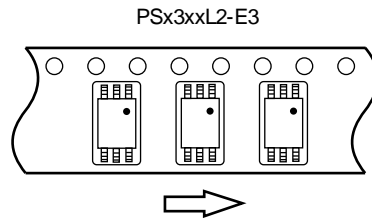

Outline and Dimensions (Tape)

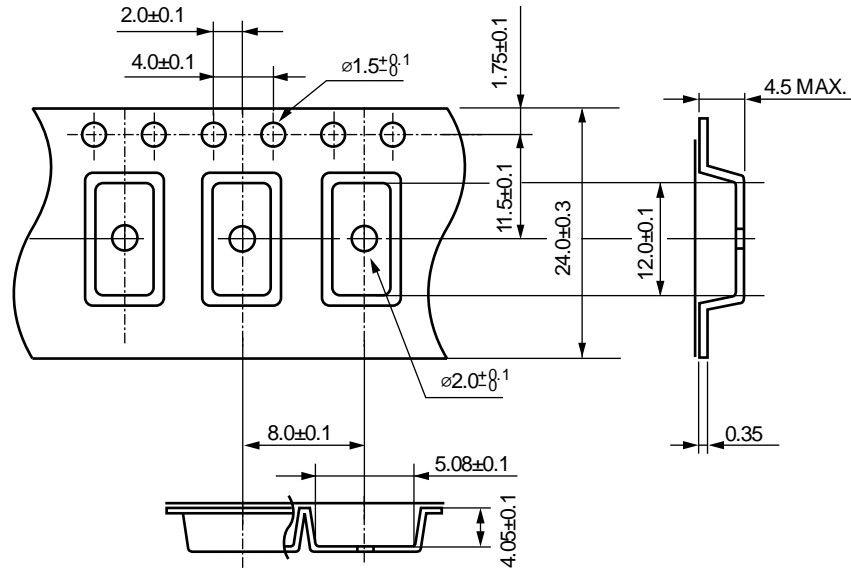

Outline and Dimensions (Reel)

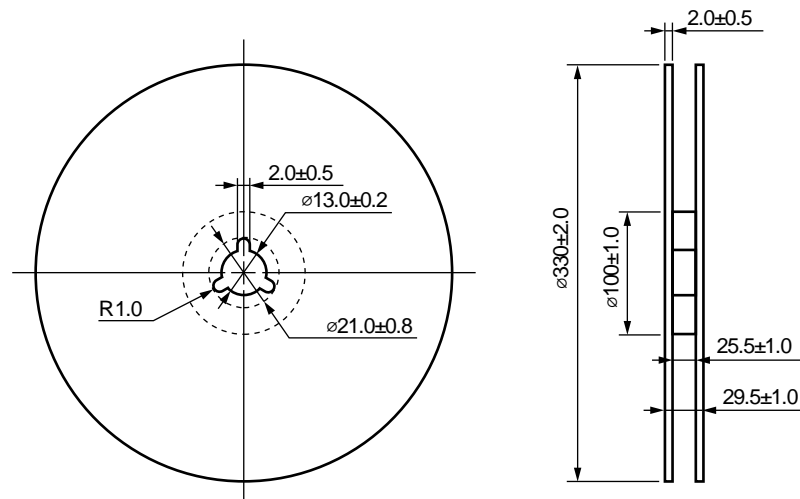

Packing: 2 000 pcs/reel

RECOMMENDED MOUNT PAD DIMENSIONS (UNIT: mm)

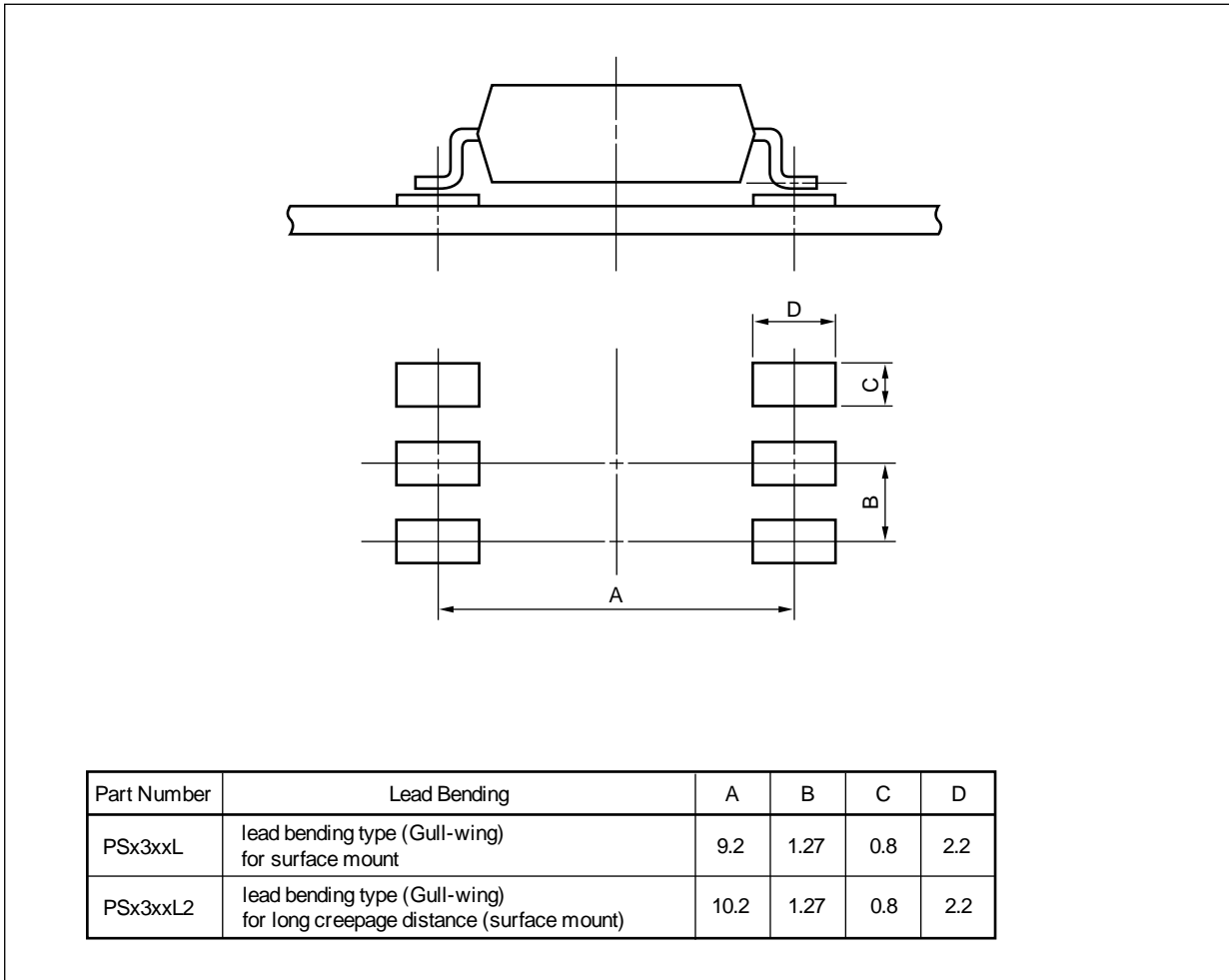

Remark All dimensions in this figure must be evaluated before use.

**NOTES ON HANDLING**

1. Recommended soldering conditions

(1) Infrared reflow soldering

- Peak reflow temperature 260 °C or below (package surface temperature)
- Time of peak reflow temperature 10 seconds or less
- Time of temperature higher than 220 °C 60 seconds or less
- Time to preheat temperature from 120 to 180 °C 120 ± 30 s
- Number of reflows Three
- Flux Rosin flux containing small amount of chlorine (The flux with a maximum chlorine content of 0.2 Wt% is recommended.)

Recommended Temperature Profile of Infrared Reflow

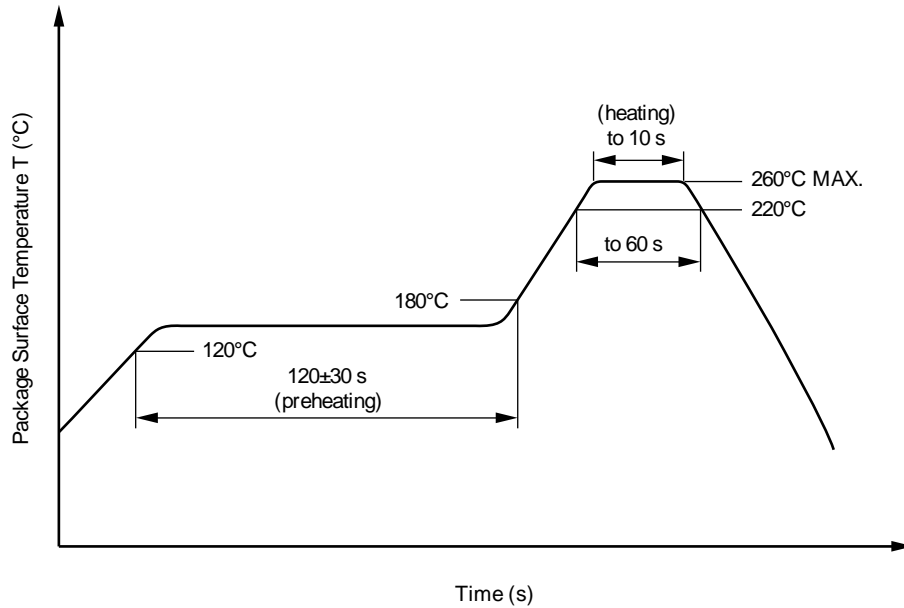

(2) Wave soldering

- Temperature 260 °C or below (molten solder temperature)
- Time 10 seconds or less
- Preheating conditions 120 °C or below (package surface temperature)
- Number of times One (Allowed to be dipped in solder including plastic mold portion.)
- Flux Rosin flux containing small amount of chlorine (The flux with a maximum chlorine content of 0.2 Wt% is recommended.)

(3) Soldering by Soldering Iron

- Peak Temperature (lead part temperature) 350 °C or below
- Time (each pins) 3 seconds or less
- Flux Rosin flux containing small amount of chlorine (The flux with a maximum chlorine content of 0.2 Wt% is recommended.)

- (a) Soldering of leads should be made at the point 1.5 to 2.0 mm from the root of the lead
- (b) Please be sure that the temperature of the package would not be heated over 100 °C

(4) Cautions

- Flux Cleaning  
Avoid cleaning with Freon based or halogen-based (chlorinated etc.) solvents.
- Do not use fixing agents or coatings containing halogen-based substances.

2. Cautions regarding noise

Be aware that when voltage is applied suddenly between the photocoupler's input and output or between collector-emitters at startup, the output side may enter the on state, even if the voltage is within the absolute maximum ratings.

**SPECIFICATION OF VDE MARKS LICENSE DOCUMENT**

Parameter	Symbol	Rating	Unit
Climatic test class (IEC 60068-1/DIN EN 60068-1)		55/110/21	
Dielectric strength maximum operating isolation voltage	$U_{IORM}$	1 130	$V_{peak}$
Test voltage (partial discharge test, procedure a for type test and random test) $U_{pr} = 1.6 \times U_{IORM.}, P_d < 5 \text{ pC}$	$U_{pr}$	1 808	$V_{peak}$
Test voltage (partial discharge test, procedure b for all devices) $U_{pr} = 1.875 \times U_{IORM.}, P_d < 5 \text{ pC}$	$U_{pr}$	2 119	$V_{peak}$
Highest permissible overvoltage	$U_{IOTM}$	8 000	$V_{peak}$
Degree of pollution (IEC 60664-1/DIN EN 60664-1 (VDE 0110-1))		2	
Comparative tracking index (IEC 60112/DIN EN 60112 (VDE 0303-11))	CTI	175	
Material group (IEC 60664-1/DIN EN 60664-1 (VDE 0110-1))		III a	
Storage temperature range	$T_{stg}$	- 55 to +125	°C
Operating temperature range	$T_A$	- 55 to +110	°C
Isolation resistance, minimum value $V_{IO} = 500 \text{ V dc at } T_A = 25 \text{ °C}$ $V_{IO} = 500 \text{ V dc at } T_A \text{ MAX. at least } 100 \text{ °C}$	Ris MIN. Ris MIN.	$10^{12}$ $10^{11}$	$\Omega$ $\Omega$
Safety maximum ratings (maximum permissible in case of fault, see thermal derating curve) Package temperature Current (input current $I_F$ , $P_{si} = 0$ ) Power (output or total power dissipation) Isolation resistance $V_{IO} = 500 \text{ V dc at } T_A = T_{si}$	$T_{si}$ $I_{si}$ $P_{si}$ Ris MIN.	175 400 700 $10^9$	°C mA mW $\Omega$

**Dependence of maximum safety ratings with package temperature**

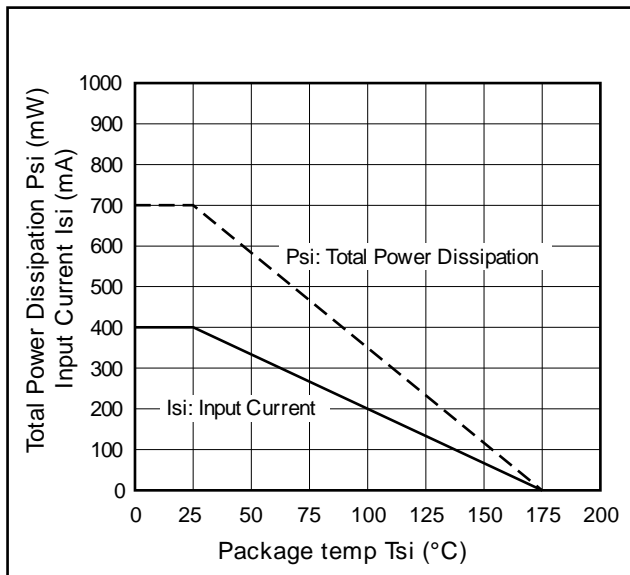

**Method a) Destructive Test, Type and Sample Test**

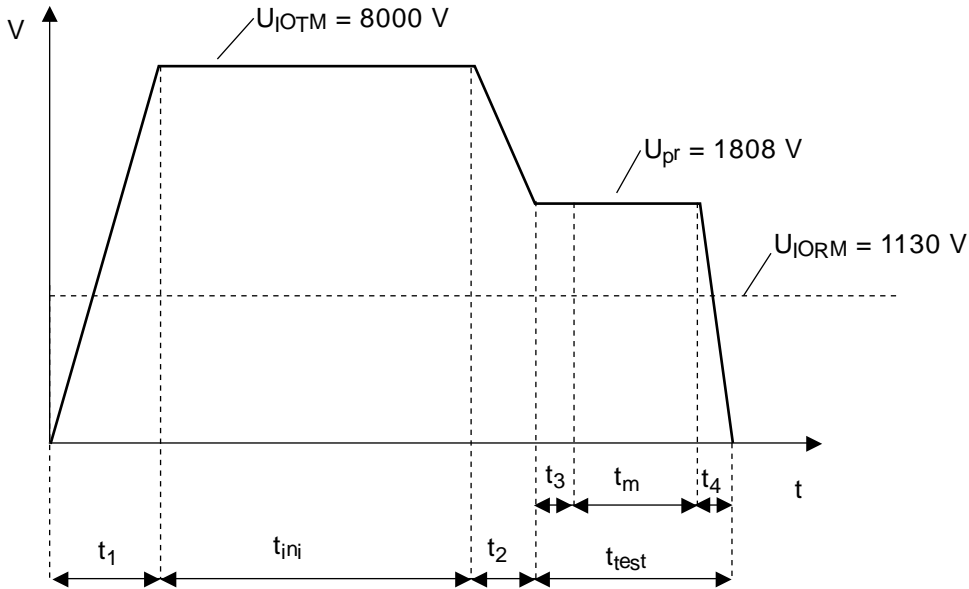

$t_1, t_2 = 1 \text{ to } 10 \text{ sec}$   
 $t_3, t_4 = 1 \text{ sec}$   
 $t_m(\text{PARTIAL DISCHARGE}) = 10 \text{ sec}$   
 $t_{\text{test}} = 12 \text{ sec}$   
 $t_{\text{ini}} = 60 \text{ sec}$

**Method b) Non-destructive Test, 100% Production Test**

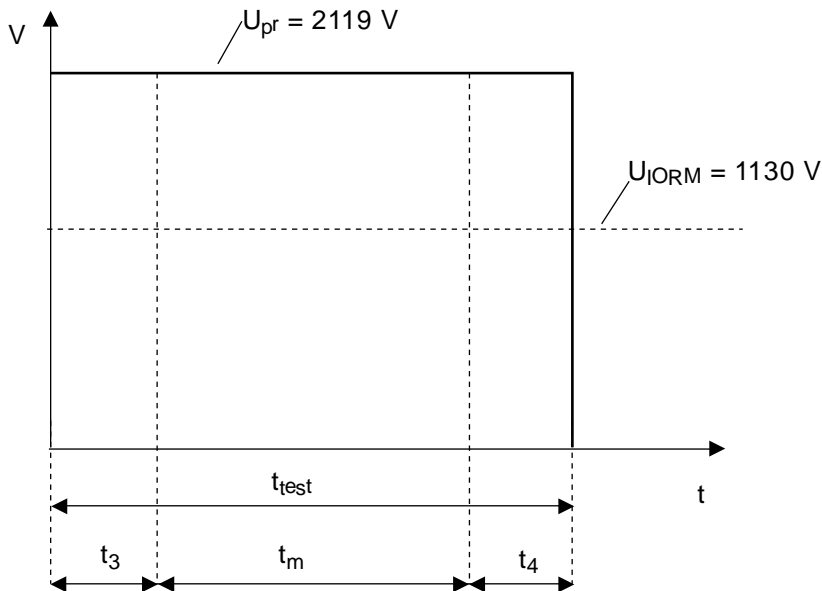

$t_3, t_4 = 0.1 \text{ sec}$   
 $t_m(\text{PARTIAL DISCHARGE}) = 1.0 \text{ sec}$   
 $t_{\text{test}} = 1.2 \text{ sec}$

<b>Caution</b>	GaAs Products	<p>This product uses gallium arsenide (GaAs). GaAs vapor and powder are hazardous to human health if inhaled or ingested, so please observe the following points.</p> <ul style="list-style-type: none"><li>• Follow related laws and ordinances when disposing of the product. If there are no applicable laws and/or ordinances, dispose of the product as recommended below.<ol style="list-style-type: none"><li>1. Commission a disposal company able to (with a license to) collect, transport and dispose of materials that contain arsenic and other such industrial waste materials.</li><li>2. Exclude the product from general industrial waste and household garbage, and ensure that the product is controlled (as industrial waste subject to special control) up until final disposal.</li></ol></li><li>• Do not burn, destroy, cut, crush, or chemically dissolve the product.</li><li>• Do not lick the product or in any way allow it to enter the mouth.</li></ul>
----------------	---------------	--

All trademarks and registered trademarks are the property of their respective owners.