

PS8352AL2

R08DS0132EJ0101

ANALOG OUTPUT TYPE
OPTICAL COUPLED ISOLATION AMPLIFIER

Rev.1.01

May 25, 2021

DESCRIPTION

The PS8352AL2 is an optically coupled isolation amplifier that uses an IC with a high-accuracy sigma-delta A/D converter and an AlGaAs light-emitting diode with high-speed response and high luminance efficiency on the input side, and an IC with a high-accuracy D/A converter on the output side.

The PS8352AL2 is designed specifically for high common mode transient immunity (CMTI) and high linearity (non-linearity). The PS8352AL2 is designed for current and voltage sensing.

FEATURES

- Non-linearity (NL200 = 0.35 % MAX.)
- High common mode transient immunity (CMTI = 10 kV/ μ s MIN.)
- High isolation voltage (BV = 5 000 Vr.m.s.)
- Gain tolerance (G = 7.92 to 8.08 (\pm 1 %))
Gain: 8 V/V TYP.
- Package: 8-pin DIP lead bending type for long creepage distance for surface mount (L2)
- Embossed tape product: PS8352AL2-E3: 2 000 pcs/reel
- Pb-Free product
- Safety standards
 - UL approved: UL1577, Double protection
 - CSA approved: CAN/CSA-C22.2 62368-1, Reinforced insulation
 - VDE approved: DIN EN 60747-5-5 (Option)

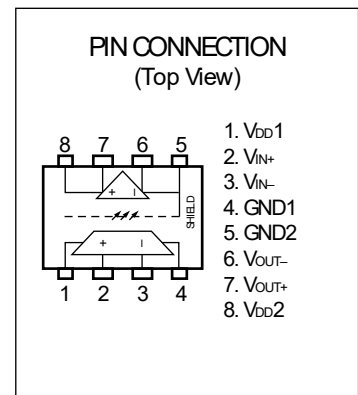

APPLICATIONS

- AC Servo, inverter
- Solar power conditioner
- Measurement equipment

Start of mass production
2015-09

PACKAGE DIMENSIONS (UNIT: mm)

Lead Bending Type (Gull-wing) For Long Creepage Distance For Surface Mount (L2)

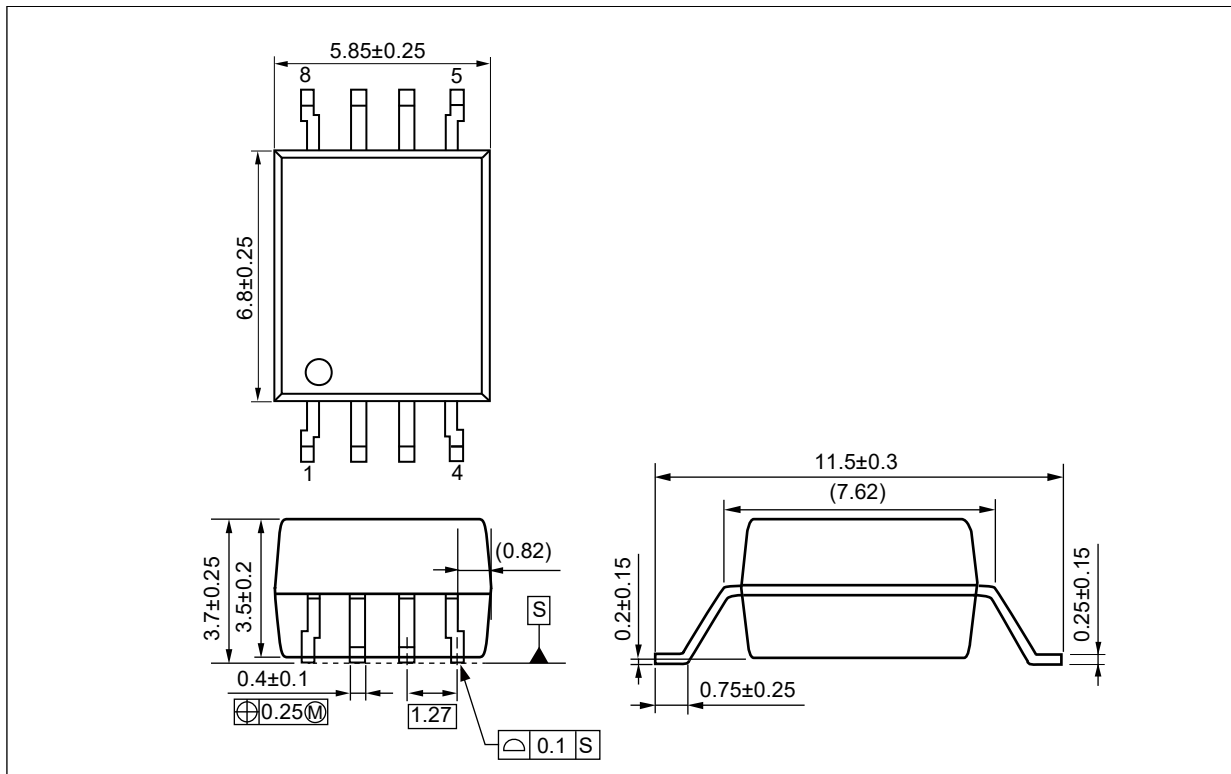

Weight: 0.316g (typ.)

PHOTOCOUPLER CONSTRUCTION

Parameter	MIN.
Air Distance	8 mm
Creepage Distance	8 mm
Isolation Distance	0.4 mm

MARKING EXAMPLE

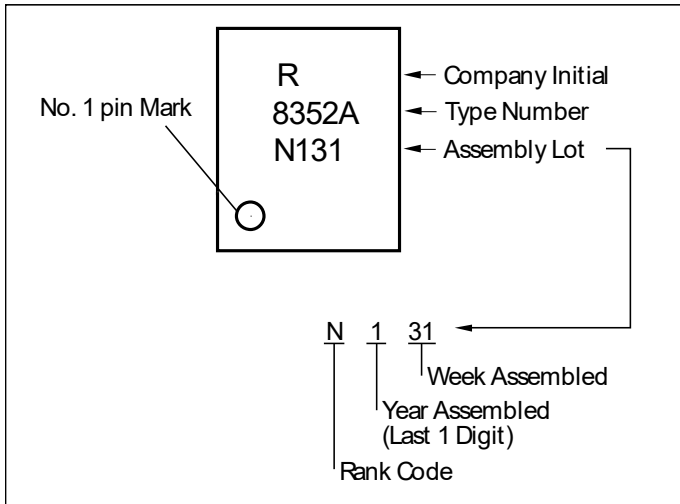

ORDERING INFORMATION

Part Number	Order Number	Solder Plating Specification	Packing Style	Safety Standard Approval	Application Part Number*1
PS8352AL2	PS8352AL2-AX	Pb-Free (Ni/Pd/Au)	20 pcs (Tape 20 pcs cut)	Standard products (UL, CSA approved)	PS8352AL2
PS8352AL2-E3	PS8352AL2-E3-AX		Embossed Tape 2 000 pcs/reel		
PS8352AL2-V	PS8352AL2-V-AX		20 pcs (Tape 20 pcs cut)	UL, CSA, DIN EN 60747-5-5 approved	
PS8352AL2-V-E3	PS8352AL2-V-E3-AX		Embossed Tape 2 000 pcs/reel		

Notes*: 1 For the application of the Safety Standard, following part number should be used.

ABSOLUTE MAXIMUM RATINGS ($T_A = 25\text{ }^\circ\text{C}$, unless otherwise specified)

Parameter	Symbol	Ratings	Unit
Operating Ambient Temperature	T_A	- 40 to +110	$^\circ\text{C}$
Storage Temperature	Tstg	- 55 to +125	$^\circ\text{C}$
Supply Voltage	V_{DD1}, V_{DD2}	0 to 5.5	V
Input Voltage	V_{IN+}, V_{IN-}	- 2 to $V_{DD1} + 0.5$	V
2 Seconds Transient Input Voltage	V_{IN+}, V_{IN-}	- 6 to $V_{DD1} + 0.5$	V
Output Voltage	V_{OUT+}, V_{OUT-}	- 0.5 to $V_{DD2} + 0.5$	V
Isolation Voltage*1	BV	5 000	Vr.m.s.

Notes*: 1. AC voltage for 1 minute at $T_A = 25\text{ }^\circ\text{C}$, RH = 60 % between input and output.
Pins 1-4 shorted together, 5-8 shorted together.

RECOMMENDED OPERATING CONDITIONS

Parameter	Symbol	MIN.	MAX.	Unit
Operating Ambient Temperature	T_A	- 40	110	$^\circ\text{C}$
Supply Voltage	V_{DD1}, V_{DD2}	4.5	5.5	V
Input Voltage (Accurate and Linear)*1	V_{IN+}, V_{IN-}	- 200	200	mV

Notes*: 1. Using $V_{IN-} = 0\text{ V}$ (to be connected to GND1) is recommended. Avoid using V_{IN-} of 2.5 V or more, because the internal test mode is activated when the voltage V_{IN-} reaches more than 2.5 V.

ELECTRICAL CHARACTERISTICS (DC Characteristics)

(TYP.: $T_A = 25\text{ }^\circ\text{C}$, $V_{IN+} = V_{IN-} = 0\text{ V}$, $V_{DD1} = V_{DD2} = 5\text{ V}$,
MIN., MAX.: refer to RECOMMENDED OPERATING CONDITIONS, unless otherwise specified)

Parameter	Symbol	Conditions	MIN.	TYP.	MAX.	Unit
Input Offset Voltage	Vos	$T_A = 25\text{ }^\circ\text{C}$	- 2	- 0.25	2	mV
			- 3	- 0.25	3	
Input Offset Voltage Drift vs. Temperature	$ dVos/dT_A $			1.6	10	$\mu\text{V}/^\circ\text{C}$
Gain *1	G	$-200\text{ mV} \leq V_{IN+} \leq 200\text{ mV}$, $T_A = 25\text{ }^\circ\text{C}$	7.92	8	8.08	V/V
Gain Drift vs. Temperature	$ dG/dT_A $			0.0006		V/V $^\circ\text{C}$
V _{OUT} Non-linearity (200 mV) *2	NL200	$-200\text{ mV} \leq V_{IN+} \leq 200\text{ mV}$		0.014	0.35	%
V _{OUT} Non-linearity (200 mV) Drift vs. Temperature	$ dNL200/dT_A $			0.0001		%/ $^\circ\text{C}$
V _{OUT} Non-linearity (100 mV) *2	NL100	$-100\text{ mV} \leq V_{IN+} \leq 100\text{ mV}$		0.011	0.2	%
Maximum Input Voltage before V _{OUT} Clipping	$ V_{IN+} $ MAX.			320		mV
Input Supply Current	I _{DD1}	$V_{IN+} = 400\text{ mV}$		13.5	16	mA
Output Supply Current	I _{DD2}	$V_{IN+} = -400\text{ mV}$		7.8	16	mA
Input Bias Current	I _{IN+}	$V_{IN+} = 0\text{ V}$	- 1	- 0.65	1	μA
Input Bias Current Drift vs. Temperature	$ dI_{IN+}/dT_A $			0.3		nA/ $^\circ\text{C}$
Low Level Saturated Output Voltage	V _{OL}	$V_{IN+} = -400\text{ mV}$		1.29		V
High Level Saturated Output Voltage	V _{OH}	$V_{IN+} = 400\text{ mV}$		3.8		V
Output Voltage ($V_{IN+} = V_{IN-} = 0\text{ V}$)	V _{OCM}	$V_{IN+} = V_{IN-} = 0\text{ V}$	2.2	2.55	2.8	V
Output Short-circuit Current	I _{OSC}			20		mA
Equivalent Input Resistance	R _{IN}			450		k Ω
V _{OUT} Output Resistance	R _{OUT}			4		Ω
Input DC Common-Mode Rejection Ratio*3	CMRR _{IN}			76		dB

- *1 The differential output voltage ($V_{OUT+} - V_{OUT-}$) with respect to the differential input voltage ($V_{IN+} - V_{IN-}$), where $V_{IN+} = -200\text{ mV}$ to 200 mV and $V_{IN-} = 0\text{ V}$ is measured under the circuit shown in **Fig. 2 NL200, G Test Circuit**. Upon the resulting chart, the gain is defined as the slope of the optimum line obtained by using the method of least squares.
- *2 The differential output voltage ($V_{OUT+} - V_{OUT-}$) with respect to the differential input voltage ($V_{IN+} - V_{IN-}$) is measured under the circuit shown in **Fig. 2 NL200, G Test Circuit**. Upon the resulting chart, the optimum line is obtained by using the method of least squares. Non-linearity is defined as the ratio (%) of the optimum line obtained by dividing [Half of the peak to peak value of the (residual) deviation] by [full-scale differential output voltage]. For example, if the differential output voltage is 3.2 V , and the peak to peak value of the (residual) deviation is 22.4 mV , while the input V_{IN+} is $\pm 200\text{ mV}$, the output non-linearity is obtained as follows:

$$NL200 = 22.4 / (2 \times 3200) = 0.35\%$$
- *3 CMRR_{IN} is defined as the ratio of the differential signal gain (when the differential signal is applied between the input pins) to the common-mode signal gain (when both input pins are connected and the signal is applied). This value is indicated in dB.

ELECTRICAL CHARACTERISTICS (AC Characteristics)

(TYP.: $T_A = 25\text{ }^\circ\text{C}$, $V_{IN+} = V_{IN-} = 0\text{ V}$, $V_{DD1} = V_{DD2} = 5\text{ V}$,
 MIN., MAX.: refer to RECOMMENDED OPERATING CONDITIONS, unless otherwise specified)

Parameter	Symbol	Conditions	MIN.	TYP.	MAX.	Unit
V_{OUT} Bandwidth (-3 dB)	f_C	$V_{IN+} = 200\text{ mVp-p}$, sine wave	50	100		kHz
V_{OUT} Noise	N_{OUT}	$V_{IN+} = 0\text{ V}$		15.6		mVr.m.s.
V_{IN} to V_{OUT} Signal Delay (50 to 10%)	t_{PD10}	$V_{IN+} = 0$ to 150 mV step		2.4	3.3	μs
V_{IN} to V_{OUT} Signal Delay (50 to 50%)	t_{PD50}			4.2	5.6	
V_{IN} to V_{OUT} Signal Delay (50 to 90%)	t_{PD90}			6.1	9.9	
V_{OUT} Rise Time/Fall Time (10 to 90%)	t_r/t_f	$V_{IN+} = 0$ to 150 mV step		3.1	6.6	μs
Common Mode Transient Immunity* ¹	CMTI	$V_{CM} = 0.5\text{ kV}$, $t_r = 20\text{ ns}$, $T_A = 25\text{ }^\circ\text{C}$	10	28		kV/ μs
Power Supply Noise Rejection* ²	PSR	$f = 1\text{ MHz}$		40		mVr.m.s.

- *1 CMTI is tested by applying a pulse that rises and falls suddenly ($V_{CM} = 0.5\text{ kV}$) between GND1 on the input side and GND2 on the output side (pins 4 and 5) by using the circuit shown in **Fig. 9 CMTI Test Circuit**. CMTI is defined at the point where the differential output voltage ($V_{OUT+} - V_{OUT-}$) fluctuates 200 mV ($>1\text{ }\mu\text{s}$) or more from the average output voltage.
- *2 This is the value of the transient voltage at the differential output when 1 V_{p-p}, 1 MHz, and 40 ns rise/fall time square wave is applied to both V_{DD1} and V_{DD2} .

TEST CIRCUIT

Fig. 1 Vos Test Circuit

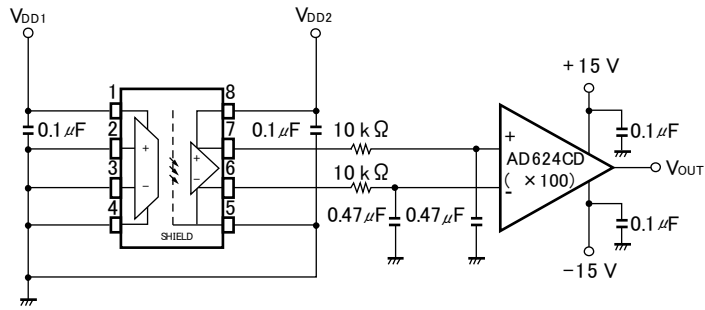

Fig. 2 NL200, G Test Circuit

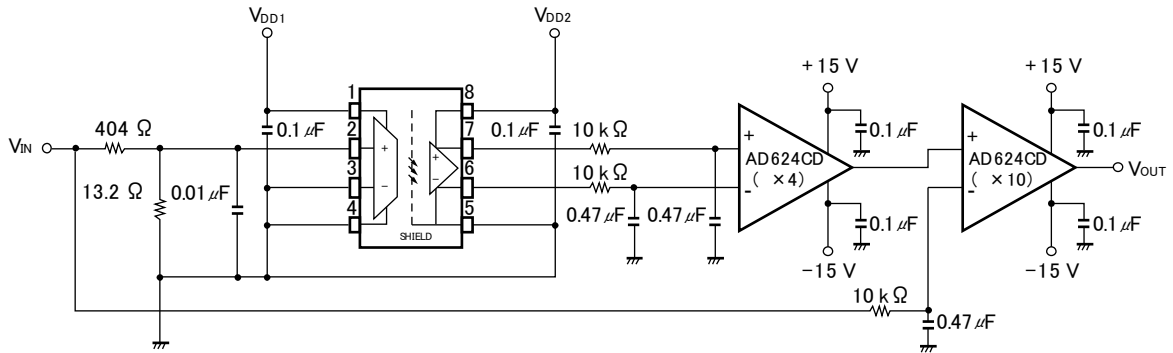

Fig. 3 I_{DD1} Test Circuit

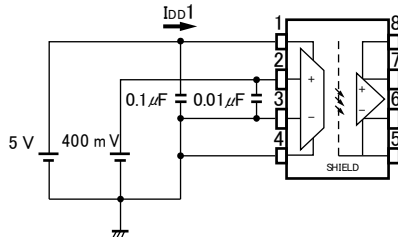

Fig. 4 I_{DD2} Test Circuit

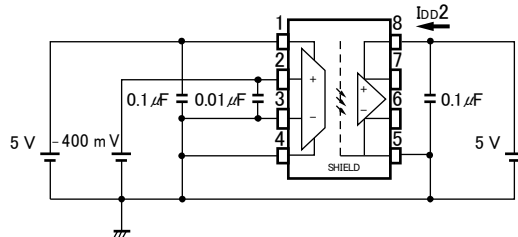

Fig. 5 IIN+ Test Circuit

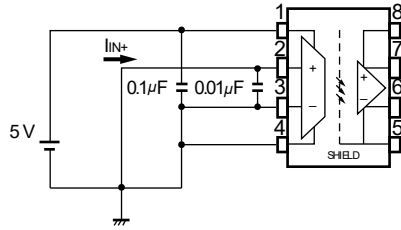
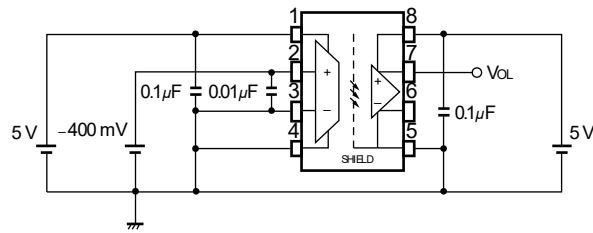
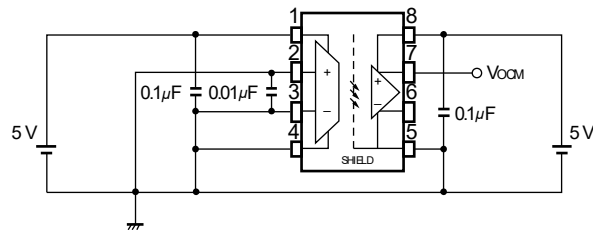

Fig. 6 VOUT Test Circuit

V_{OL}



V_{oCM}



V_{OH}

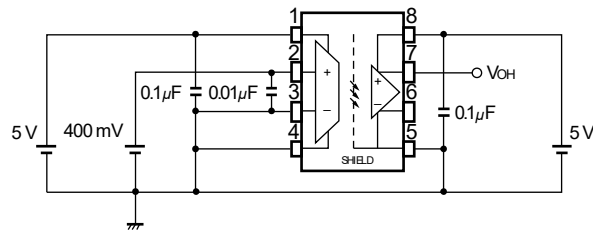

Fig. 7 |IOSC| Test Circuit

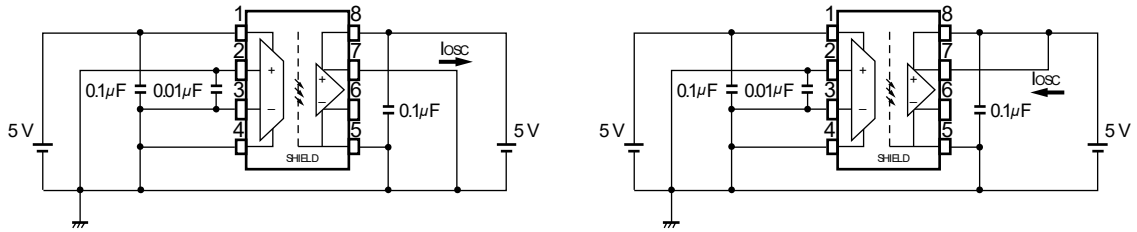

Fig. 8 tPD Test Circuit

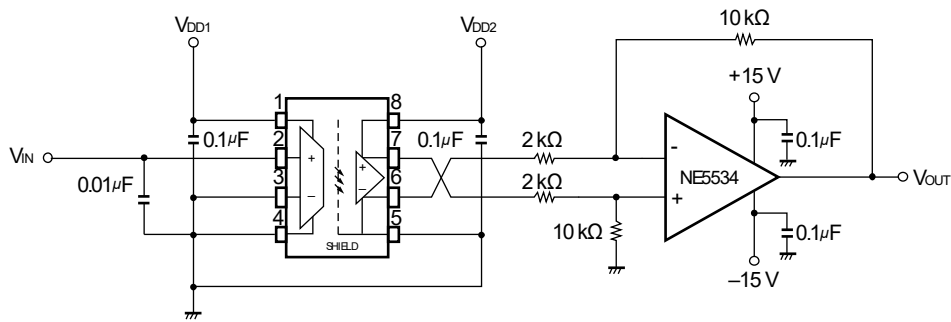
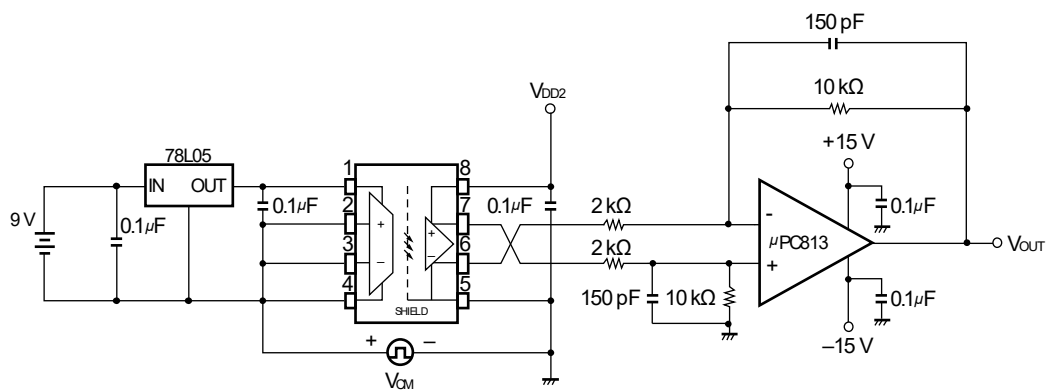
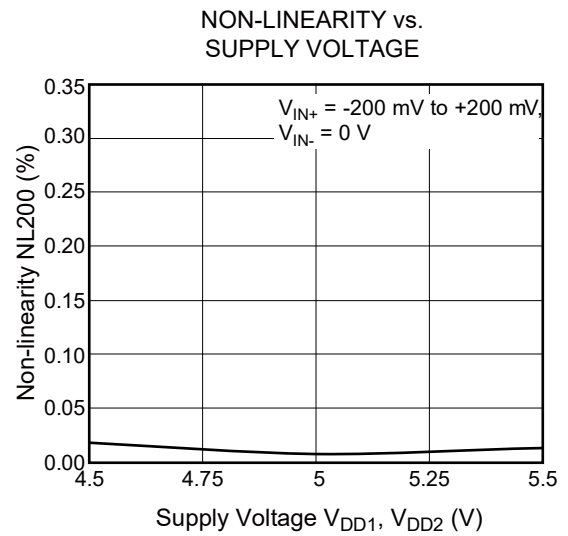
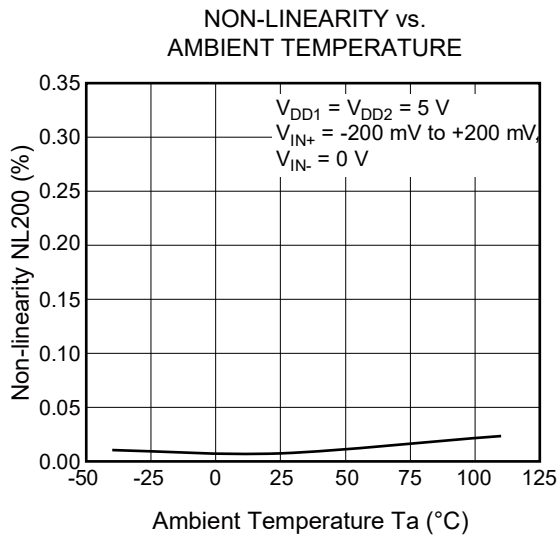
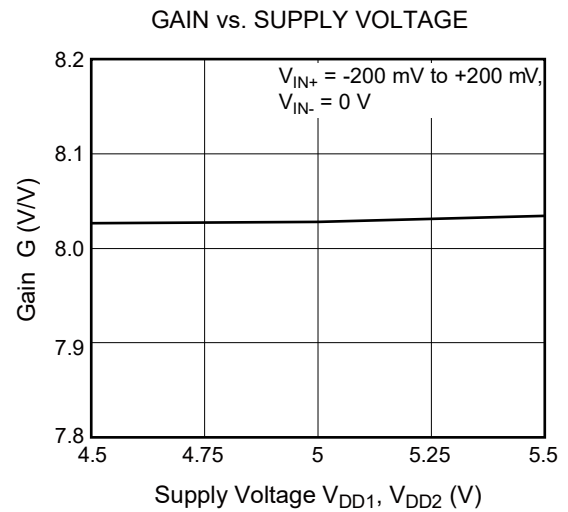
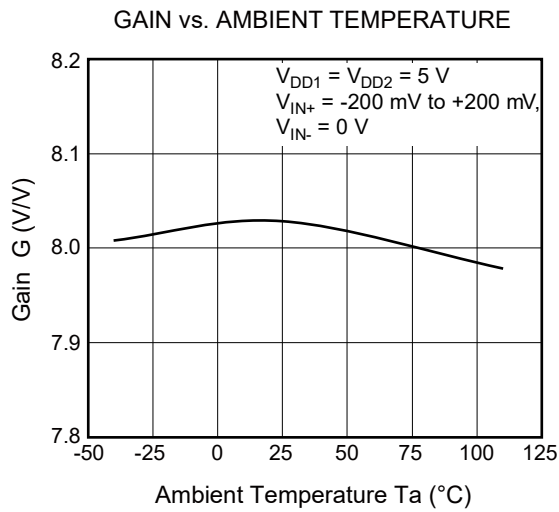
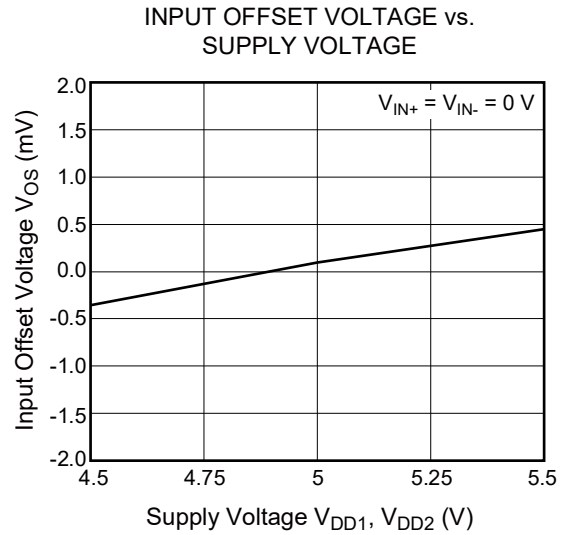
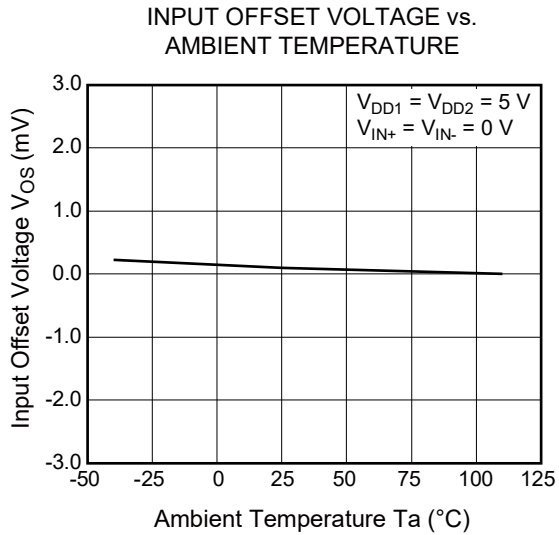

Fig. 9 CMTI Test Circuit



TYPICAL CHARACTERISTICS (T_A = 25 °C unless otherwise specified)



Remark The graphs indicate nominal characteristics.

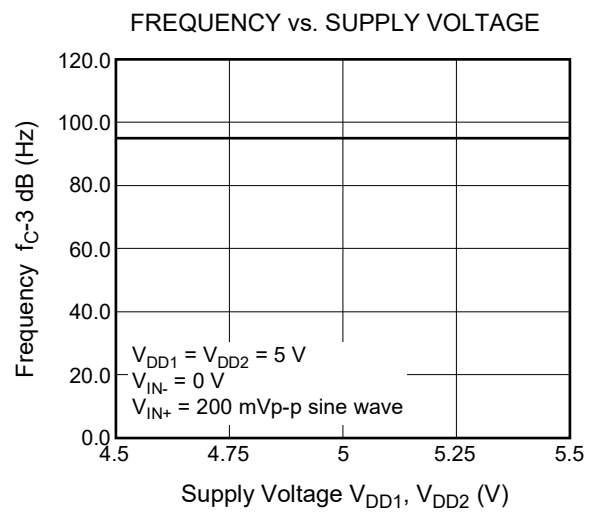
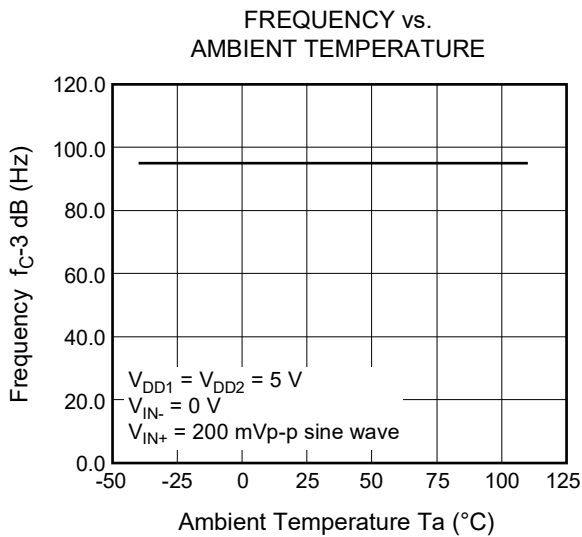
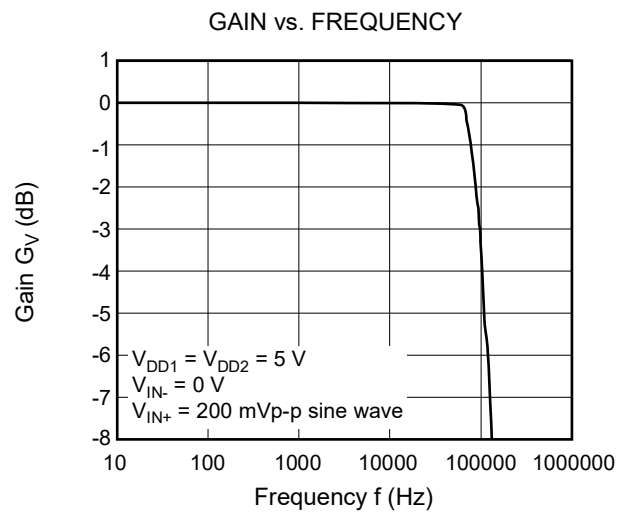
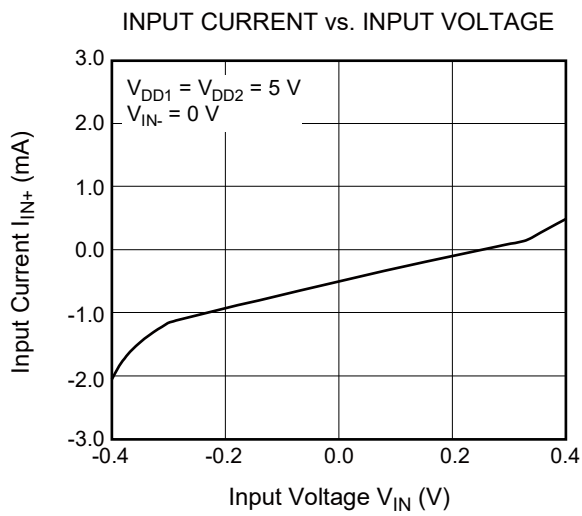
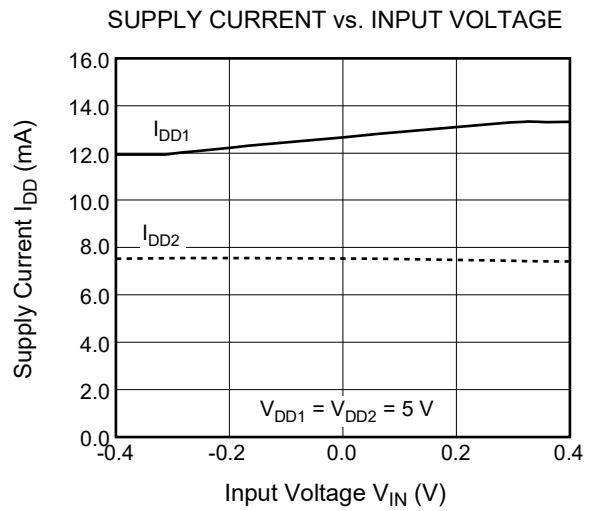
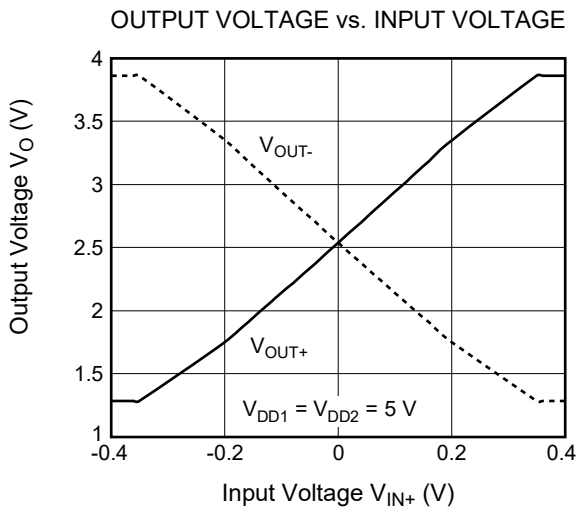

Remark The graphs indicate nominal characteristics.

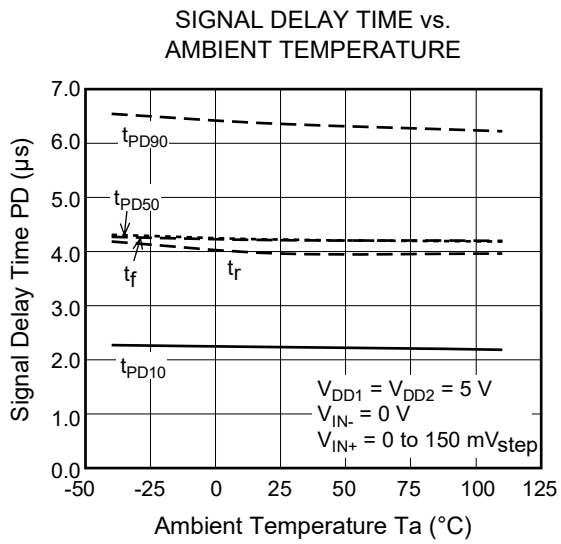

Remark The graphs indicate nominal characteristics.

TAPING SPECIFICATIONS (UNIT: mm)

Tape Direction

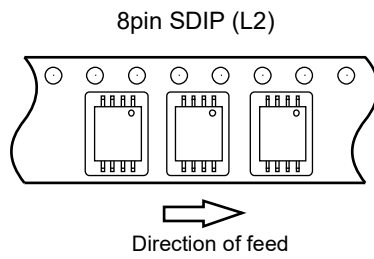

Outline and Dimensions (Tape)

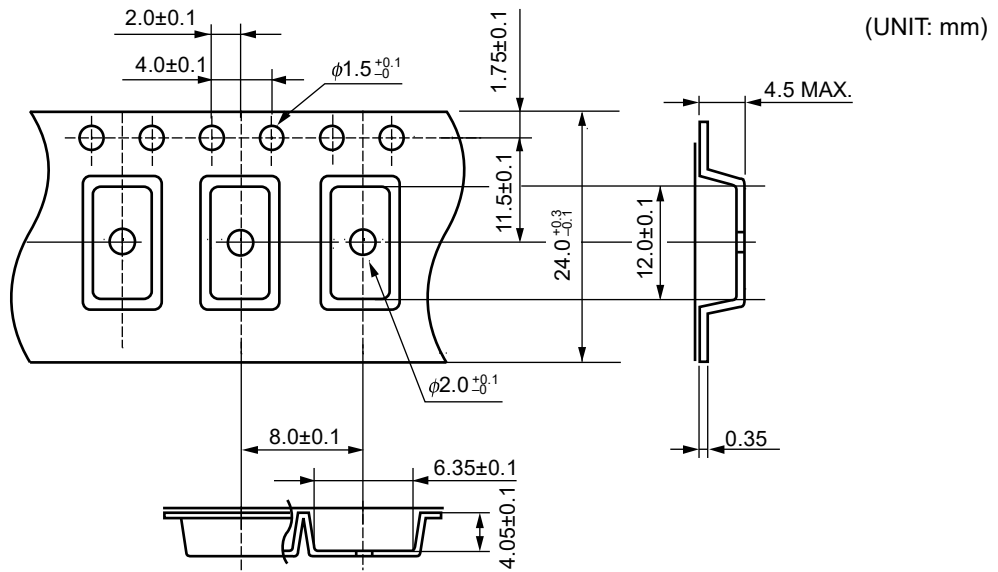

Outline and Dimensions (Reel)

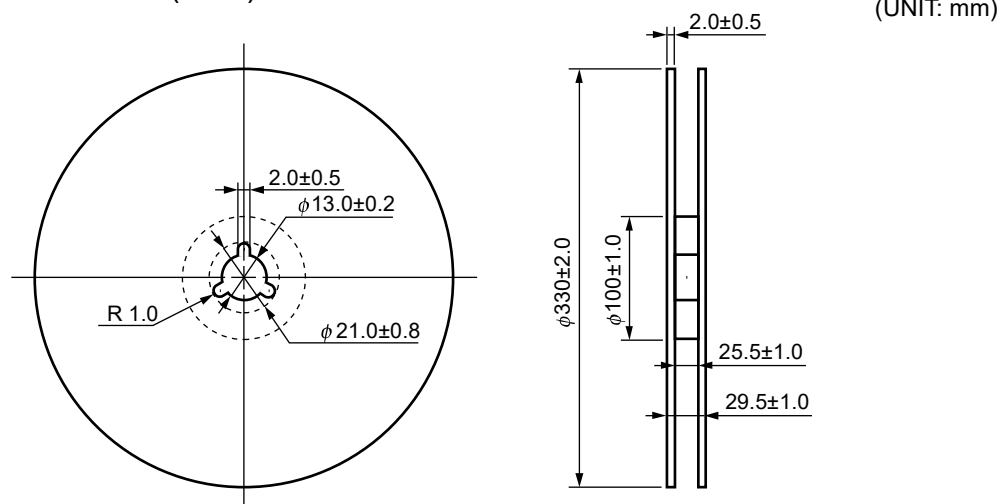

Packing: 2 000 pcs/reel

RECOMMENDED MOUNT PAD DIMENSIONS (UNIT: mm)

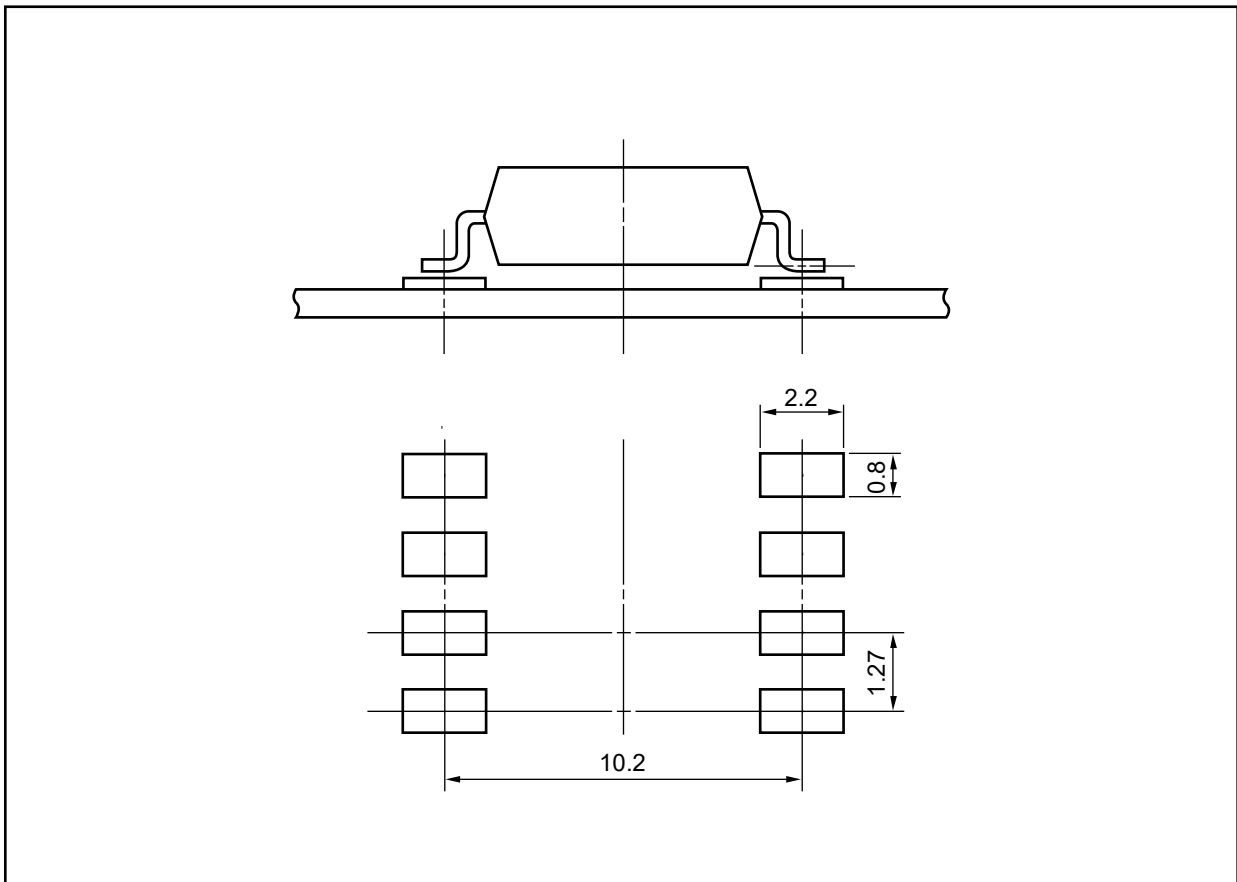

【8pin SDIP (L2)】

Remark All dimensions in this figure must be evaluated before use.

NOTES ON HANDLING

1. Recommended soldering conditions

(1) Infrared reflow soldering

- Peak reflow temperature 260 °C or below (package surface temperature)
- Time of peak reflow temperature 10 seconds or less
- Time of temperature higher than 220 °C 60 seconds or less
- Time to preheat temperature from 120 to 180 °C 120 ± 30 s
- Number of reflows Three
- Flux Rosin flux containing small amount of chlorine (The flux with a maximum chlorine content of 0.2 Wt% is recommended.)

Recommended Temperature Profile of Infrared Reflow

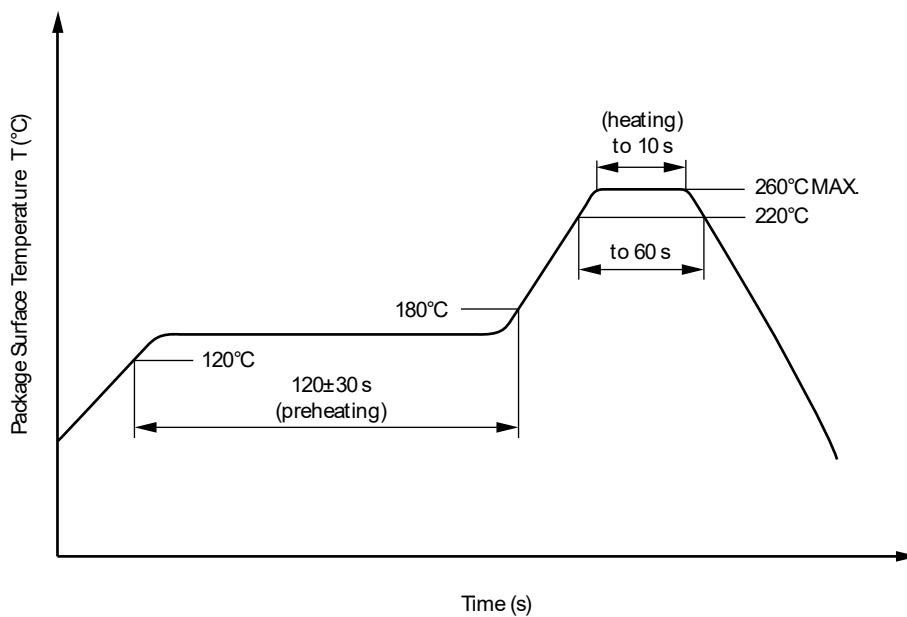

(2) Wave soldering

- Temperature 260 °C or below (molten solder temperature)
- Time 10 seconds or less
- Preheating conditions 120 °C or below (package surface temperature)
- Number of times One (Allowed to be dipped in solder including plastic mold portion.)
- Flux Rosin flux containing small amount of chlorine (The flux with a maximum chlorine content of 0.2 Wt% is recommended.)

(3) Soldering by Soldering Iron

- Peak Temperature (lead part temperature) 350 °C or below
- Time (each pins) 3 seconds or less
- Flux Rosin flux containing small amount of chlorine
(The flux with a maximum chlorine content of 0.2 Wt% is recommended.)

(a) Soldering of leads should be made at the point 1.5 to 2.0 mm from the root of the lead

(b) Please be sure that the temperature of the package would not be heated over 100°C

(4) Cautions

- Flux Cleaning
Avoid cleaning with Freon based or halogen-based (chlorinated etc.) solvents.
- Do not use fixing agents or coatings containing halogen-based substances.

2. Cautions regarding noise

Be aware that when voltage is applied suddenly between the photocoupler's input and output at startup, the output transistor may enter the on state, even if the voltage is within the absolute maximum ratings.

USAGE CAUTIONS

1. Usage cautions

- (1) This product is weak for static electricity by designed with high-speed integrated circuit so protect against static electricity when handling.
- (2) When the primary power supply (V_{DD1}) is off and only the secondary power supply (V_{DD2}) is being applied ($V_{DD1} = 0$ V and $V_{DD2} = 5$ V), V_{OUT+} outputs a low level, and V_{OUT-} outputs a high level ($V_{OUT+} = 1.3$ V TYP., $V_{OUT-} = 3.8$ V TYP.), regardless of the input voltages (V_{IN+} and V_{IN-}).
- (3) The output level of V_{OUT+} and V_{OUT-} might be unstable for several seconds immediately after the secondary power supply (V_{DD2}) is applied while the primary power supply (V_{DD1}) is being applied.

2. Board designing

- (1) By-pass capacitor of more than $0.1 \mu\text{F}$ is used between V_{CC} and GND near device. Also, ensure that the distance between the leads of the photocoupler and capacitor is no more than 10 mm.
- (2) Keep the pattern connected the input (V_{IN+} , V_{IN-}) and the output (V_{OUT+} , V_{OUT-}), respectively, as short as possible.
- (3) Do not connect any routing to the portion of the frame exposed between the pins on the package of the photocoupler. If connected, it will affect the photocoupler's internal voltage and the photocoupler will not operate normally.
- (4) Because the maximum frequency of the signal input to the photocoupler must be lower than the allowable frequency band, be sure to connect an anti-aliasing filter (an RC filter with $R = 68 \Omega$ and $C = 0.01 \mu\text{F}$, for example).
- (5) The signals output from the PS8352A include noise elements such as chopping noise and quantization noise generated internally. Therefore, be sure to restrict the output frequency to the required bandwidth by adding a low-pass filter function (an RC filter with $R = 10 \text{ k}\Omega$ and $C = 150 \text{ pF}$, for example) to the operational amplifier (post amplifier) in the next stage to the PS8352A.

3. Avoid storage at a high temperature and high humidity.

SPECIFICATION OF VDE MARKS LICENSE DOCUMENT

Parameter	Symbol	Speck	Unit
Climatic test class (IEC 60068-1/DIN EN 60068-1)		40/110/21	
Dielectric strength maximum operating isolation voltage Test voltage (partial discharge test, procedure a for type test and random test) $U_{pr} = 1.6 \times U_{IORM}, P_d < 5 \text{ pC}$	U_{IORM} U_{pr}	1 130 1 808	V_{peak} V_{peak}
Test voltage (partial discharge test, procedure b for all devices) $U_{pr} = 1.875 \times U_{IORM}, P_d < 5 \text{ pC}$	U_{pr}	2 119	V_{peak}
Highest permissible overvoltage	U_{IOTM}	8 000	V_{peak}
Degree of pollution (IEC 60664-1/DIN EN 60664-1 (VDE 0110-1))		2	
Comparative tracking index (IEC 60112/DIN EN 60112 (VDE 0303 Part 11))	CTI	175	
Material group (IEC 60664-1/DIN EN 60664-1 (VDE 0110-1))		III a	
Storage temperature range	T_{stg}	-55 to +125	°C
Operating temperature range	T_A	-40 to +110	°C
Isolation resistance, minimum value $V_{IO} = 500 \text{ V dc at } T_A = 25^\circ\text{C}$ $V_{IO} = 500 \text{ V dc at } T_A \text{ MAX. at least } 100^\circ\text{C}$	Ris MIN. Ris MIN.	10^{12} 10^{11}	Ω Ω
Safety maximum ratings (maximum permissible in case of fault, see thermal derating curve) Package temperature Current (input current I_F , $P_{si} = 0$) Power (output or total power dissipation) Isolation resistance $V_{IO} = 500 \text{ V dc at } T_A = T_{si}$	T_{si} I_{si} P_{si} Ris MIN.	175 400 700 10^9	°C mA mW Ω

Dependence of maximum safety ratings with package temperature

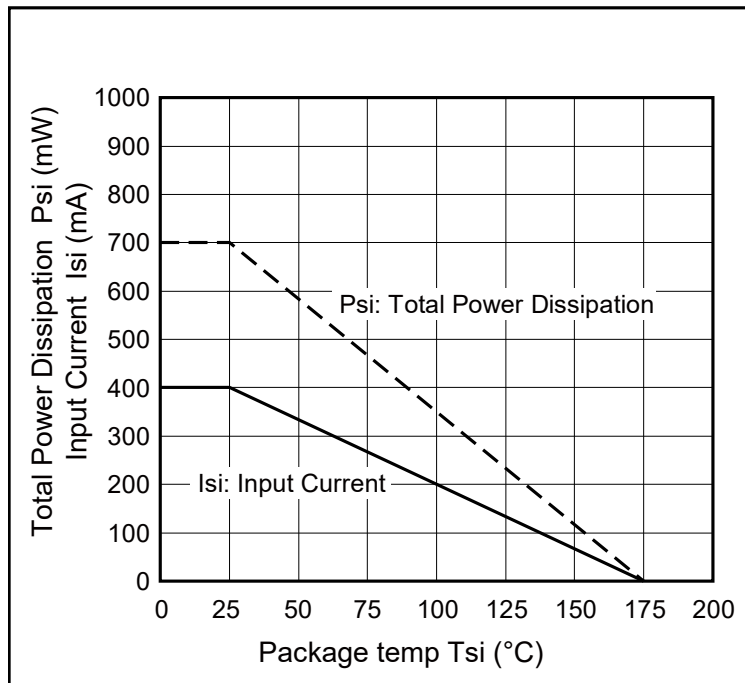

Method a Destructive Test, Type and Sample Test

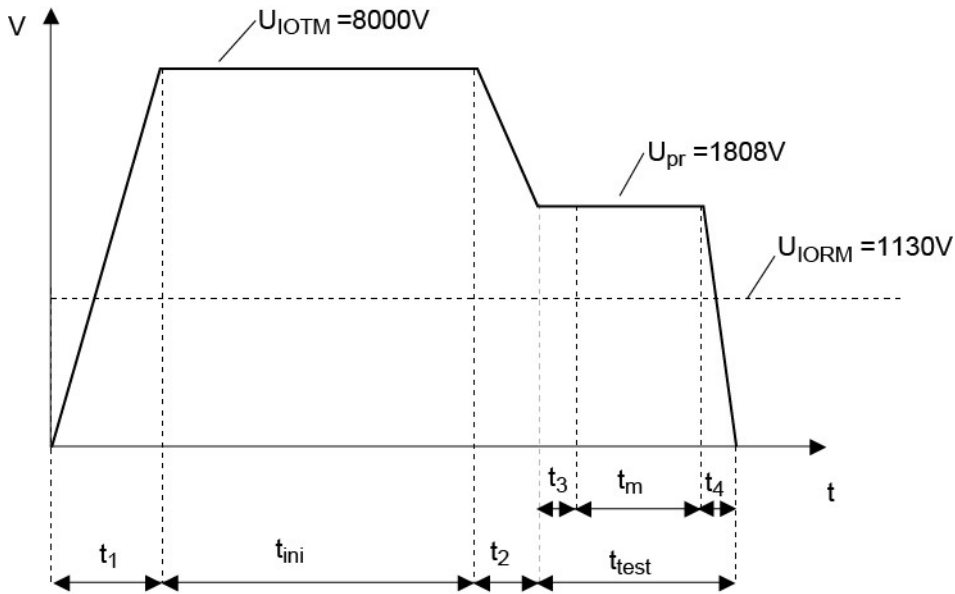

$t_1, t_2 = 1 \text{ to } 10 \text{ sec}$
 $t_3, t_4 = 1 \text{ sec}$
 $t_m(\text{PARTIAL DISCHARGE}) = 10 \text{ sec}$
 $t_{test} = 12 \text{ sec}$
 $t_{ini} = 60 \text{ sec}$

Method b Non-destructive Test, 100% Production Test

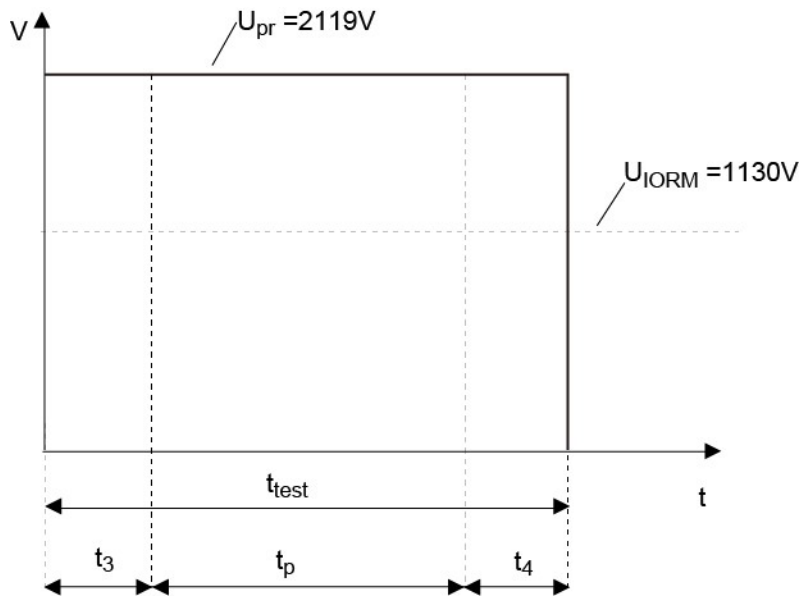

$t_3, t_4 = 0.1 \text{ sec}$
 $t_m(\text{PARTIAL DISCHARGE}) = 1.0 \text{ sec}$
 $t_{test} = 1.2 \text{ sec}$

Caution	GaAs Products	<p>This product uses gallium arsenide (GaAs). GaAs vapor and powder are hazardous to human health if inhaled or ingested, so please observe the following points.</p> <ul style="list-style-type: none">• Follow related laws and ordinances when disposing of the product. If there are no applicable laws and/or ordinances, dispose of the product as recommended below.<ol style="list-style-type: none">1. Commission a disposal company able to (with a license to) collect, transport and dispose of materials that contain arsenic and other such industrial waste materials.2. Exclude the product from general industrial waste and household garbage, and ensure that the product is controlled (as industrial waste subject to special control) up until final disposal.• Do not burn, destroy, cut, crush, or chemically dissolve the product.• Do not lick the product or in any way allow it to enter the mouth.
----------------	---------------	--