

PS9307AL, PS9307AL2

R08DS0122EJ0101

Rev.1.01

0.6 A OUTPUT CURRENT, HIGH CMR, IGBT GATE DRIVE, 6-PIN SDIP PHOTOCOUPLER

Dec 16, 2021

DESCRIPTION

The PS9307AL and PS9307AL2 are optical coupled isolators containing an AlGaAs LED on the input side and a photo diode, a signal processing circuit and power MOSFETs on the output side on one chip.

The PS9307AL and PS9307AL2 are in 6-pin plastic SDIP (Shrink Dual In-line Package). The PS9307AL2 has 8 mm creepage distance. The mount area of 6-pin plastic SDIP is half size of 8-pin DIP.

The PS9307AL and PS9307AL2 are designed specifically for high common mode transient immunity (CMR) and high switching speed. It is suitable for driving IGBTs and MOS FETs.

The PS9307AL is lead bending type (Gull-wing) for surface mounting.

The PS9307AL2 is lead bending type for long creepage distance (Gull-wing) for surface mount.

FEATURES

- Long creepage distance (8 mm MIN.: PS9307AL2)
- Half size of 8-pin DIP
- Peak output current (0.6 A MAX., 0.4 A MIN.)
- High speed switching ($t_{PLH} - t_{PHL} = 150 \text{ ns MAX.}$)
- High common mode transient immunity ($CM_H, CM_L = \pm 50 \text{ kV}/\mu\text{s MIN.}$)
- Operating Ambient Temperature (125 °C)
- Embossed tape product : PS9307AL-E3, PS9307AL2-E3: 2 000 pcs/reel
- Pb-Free product
- Safety standards
 - UL approved: UL1577, Double protection
 - CSA approved: CAN/CSA-C22.2 No.62368-1, Reinforced insulation
 - SEMKO approved: EN 62368-1, IEC 62368-1, Reinforced insulation
 - VDE approved: DIN EN 60747-5-5 (Option)

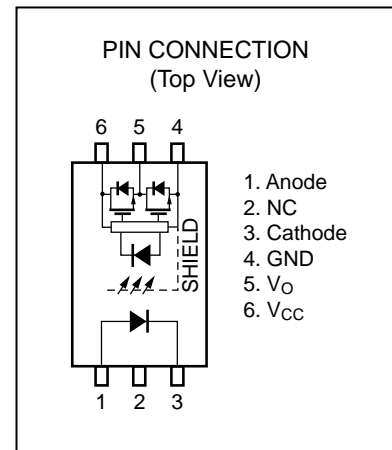

APPLICATIONS

- IGBT, Power MOS FET Gate Driver
- Industrial inverter
- AC Servo

Start of mass production
Jan.2014

PACKAGE DIMENSIONS (UNIT: mm)

Lead Bending Type (Gull-wing) For Surface Mount

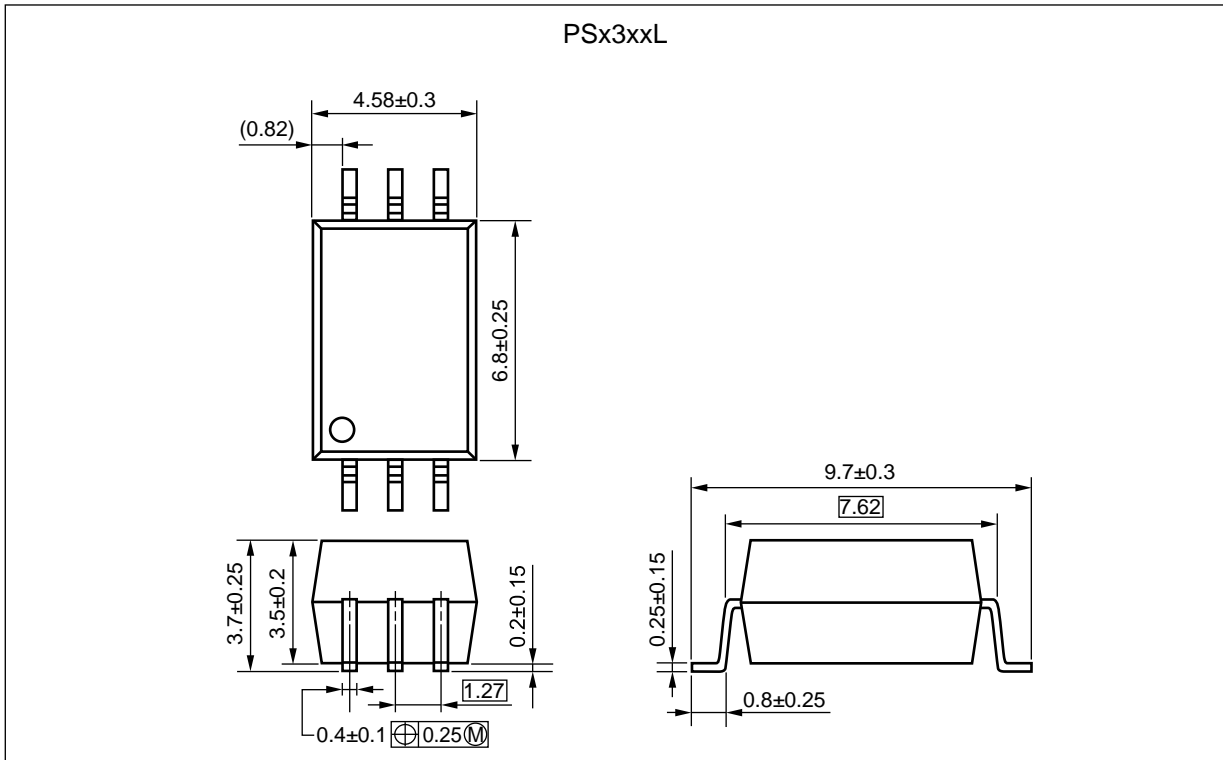

Lead Bending Type (Gull-wing) For Long Creepage Distance (Surface Mount)

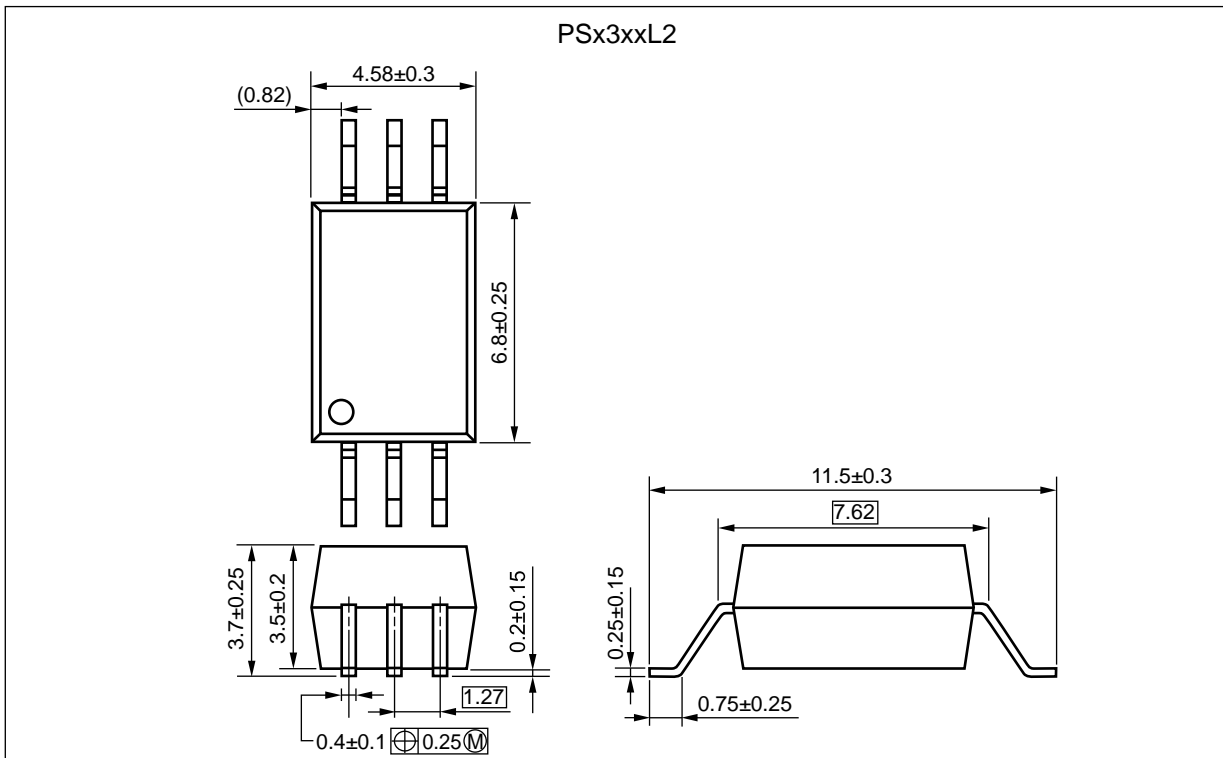

Weight: 0.27g (typ.)

PHOTOCOUPLER CONSTRUCTION

Parameter	PS9307AL	PS9307AL2
Air Distance (MIN.)	7 mm	8 mm
Creepage Distance (MIN.)	7 mm	8 mm
Isolation Distance (MIN.)	0.4 mm	0.4 mm

MARKING EXAMPLE

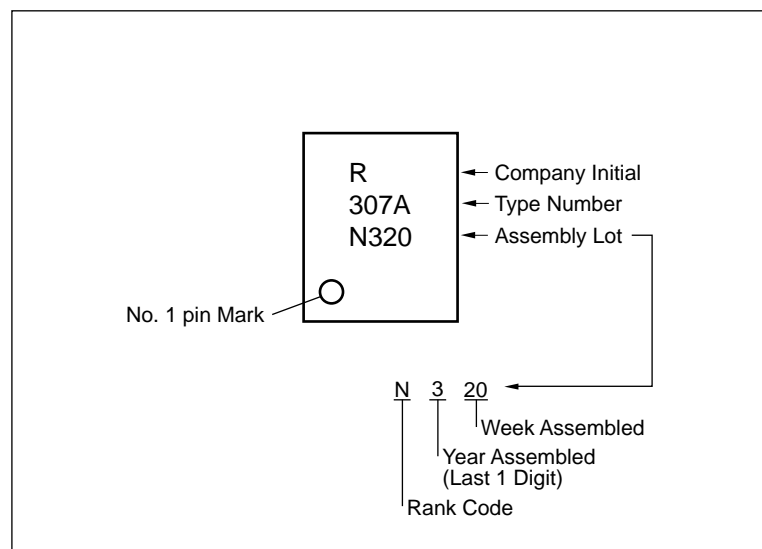

ORDERING INFORMATION

Part Number	Order Number	Solder Plating Specification	Packing Style	Safety Standard Approval	Application Part Number*1
PS9307AL	PS9307AL-AX	Pb-Free (Ni/Pd/Au)	20 pcs (Tape 20 pcs cut)	Standard products (UL, CSA, SEMKO approved)	PS9307AL
PS9307AL-E3	PS9307AL-E3-AX		Embossed Tape 2 000 pcs/reel		
PS9307AL2	PS9307AL2-AX		20 pcs (Tape 20 pcs cut)		PS9307AL2
PS9307AL2-E3	PS9307AL2-E3-AX		Embossed Tape 2 000 pcs/reel		
PS9307AL-V	PS9307AL-V-AX		UL, CSA, SEMKO, DIN EN 60747-5-5 approved	20 pcs (Tape 20 pcs cut)	PS9307AL
PS9307AL-V-E3	PS9307AL-V-E3-AX			Embossed Tape 2 000 pcs/reel	
PS9307AL2-V	PS9307AL2-V-AX			PS9307AL2	
PS9307AL2-V-E3	PS9307AL2-V-E3-AX				20 pcs (Tape 20 pcs cut)
		Embossed Tape 2 000 pcs/reel			

Note: *1. For the application of the Safety Standard, following part number should be used.

ABSOLUTE MAXIMUM RATINGS (T_A = 25 °C, unless otherwise specified)

Parameter		Symbol	Ratings	Unit
Diode	Forward Current	I _F	25	mA
	Peak Transient Forward Current (Pulse Width < 1 μs)	I _{F (TRAN)}	1.0	A
	Reverse Voltage	V _R	5	V
	Power Dissipation *1	P _D	45	mW
Detector	High Level Peak Output Current *2	I _{OH (PEAK)}	0.6	A
	Low Level Peak Output Current *2	I _{OL (PEAK)}	0.6	A
	Supply Voltage	(V _{CC} - V _{EE})	0 to 35	V
	Output Voltage	V _O	0 to V _{CC}	V
	Power Dissipation *3	P _C	250	mW
Isolation Voltage *4		BV	5 000	Vr.m.s.
Operating Frequency		f	250	kHz
Operating Ambient Temperature		T _A	-40 to +125	°C
Storage Temperature		T _{stg}	-55 to +150	°C

Notes: *1. Reduced to 1.2 mW/°C at T_A = 110 °C or more.

*2. Maximum pulse width = 10 μs, Maximum duty cycle = 0.5 %

*3. Reduced to 3.9 mW/°C at T_A = 85 °C or more.

*4. AC voltage for 1 minute at T_A = 25 °C, RH = 60 % between input and output.

Pins 1-3 shorted together, 4-6 shorted together.

RECOMMENDED OPERATING CONDITIONS

Parameter	Symbol	MIN.	TYP.	MAX.	Unit
Supply Voltage	(V _{CC} - V _{EE})	10		30	V
Forward Current (ON)	I _{F (ON)}	8	10	12	mA
Forward Voltage (OFF)	V _{F (OFF)}	-2		0.8	V
Operating Ambient Temperature	T _A	-40		125	°C

ELECTRICAL CHARACTERISTICS (at RECOMMENDED OPERATING CONDITIONS, V_{EE} = GND, unless otherwise specified)

Parameter		Symbol	Conditions	MIN.	TYP.*1	MAX.	Unit
Diode	Forward Voltage	V _F	I _F = 10 mA, T _A = 25 °C	1.2	1.56	1.8	V
	Reverse Current	I _R	V _R = 3 V, T _A = 25 °C			10	μA
	Input Capacitance	C _{IN}	f = 1 MHz, V _F = 0 V		30		pF
Detector	High Level Output Current	I _{OH}	V _O = (V _{CC} - 4 V) ^{*2}	0.2			A
			V _O = (V _{CC} - 10 V) ^{*3}	0.4			
	Low Level Output Current	I _{OL}	V _O = (V _{EE} + 2.5 V) ^{*2}	0.2			A
			V _O = (V _{EE} + 10 V) ^{*3}	0.4			
	High Level Output Voltage	V _{OH}	I _O = -100 mA ^{*4}	V _{CC} - 3.0	V _{CC} - 1.5		V
	Low Level Output Voltage	V _{OL}	I _O = 100 mA		0.25	1.0	V
	High Level Supply Current	I _{CCH}	V _O = Open		1.4	2.0	mA
	Low Level Supply Current	I _{CCL}	V _O = Open		1.3	2.0	mA
	UVLO Threshold	V _{UVLO+} V _{UVLO-}	V _O > 5 V, I _F = 10 mA		8.6	9.8	V
				6.8	8.2		
UVLO Hysteresis	UVLO _{HYS}	V _O > 5 V, I _F = 10 mA		0.4		V	
Coupled	Threshold Input Current (L → H)	I _{FLH}	I _O = 0 mA, V _O > 5 V		2.5	5.0	mA
	Threshold Input Voltage (H → L)	V _{FHL}	I _O = 0 mA, V _O < 5 V	0.8			V

Notes: *1. Typical values at T_A = 25 °C, V_{CC} - V_{EE} = 30 V.

*2. Maximum pulse width = 50 μs, Maximum duty cycle = 0.2 %.

*3. Maximum pulse width = 10 μs, Maximum duty cycle = 0.5 %.

*4. V_{OH} is measured with the DC load current in this testing (Maximum pulse width = 2 ms, Maximum duty cycle = 20 %).

SWITCHING CHARACTERISTICS (at RECOMMENDED OPERATING CONDITIONS, V_{EE} = GND, unless otherwise specified)

Parameter	Symbol	Conditions	MIN.	TYP.*1	MAX.	Unit
Propagation Delay Time (L → H)	t _{PLH}	R _g = 47 Ω, C _g = 3 nF, f = 50 kHz, Duty Cycle = 50%, I _F = 10 mA, V _{CC} = 30 V	50	100	150	ns
Propagation Delay Time (H → L)	t _{PHL}		50	90	150	ns
Pulse Width Distortion (PWD)	t _{PHL} - t _{PLH}		5	50	ns	
Propagation Delay Time (Difference Between Any Two Products)	t _{PHL} - t _{PLH}		-80		80	ns
Rise Time	t _r			6		ns
Fall Time	t _f			7		ns
Common Mode Transient Immunity at High Level Output	CM _H		T _A = 25 °C, I _F = 10 mA, V _{CC} = 30 V, V _{CM} = 1.5 kV	50		
Common Mode Transient Immunity at Low Level Output	CM _L	T _A = 25 °C, I _F = 0 mA, V _{CC} = 30 V, V _{CM} = 1.5 kV	50			kV/μs

Notes: *1. Typical values at T_A = 25 °C, V_{CC} - V_{EE} = 30 V.

TEST CIRCUIT

Fig. 1 I_{OH} Test Circuit

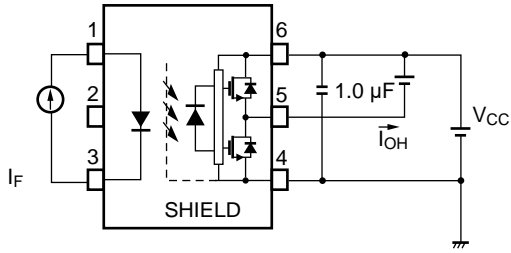

Fig. 2 I_{OL} Test Circuit

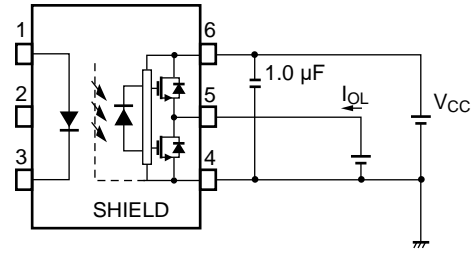

Fig. 3 V_{OH} Test Circuit

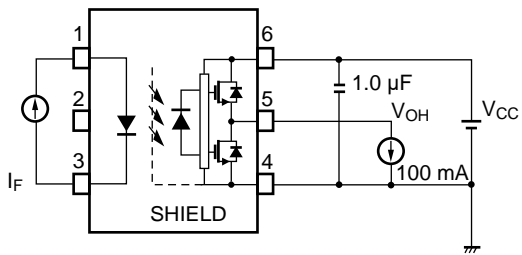

Fig. 4 V_{OL} Test Circuit

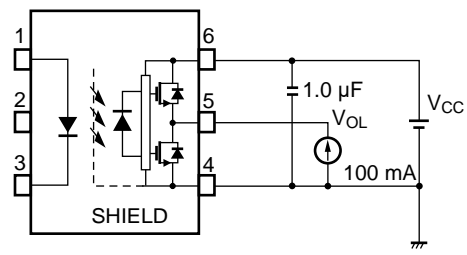

Fig. 5 I_{CCH}/I_{CCL} Test Circuit

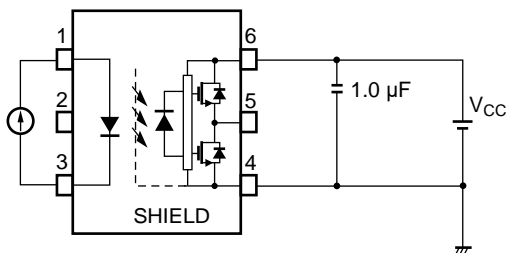

Fig. 6 UVLO Test Circuit

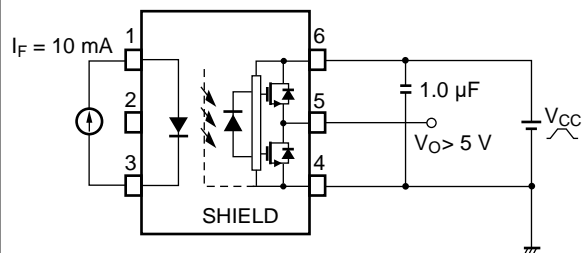

Fig. 7 I_{FLH} Test Circuit

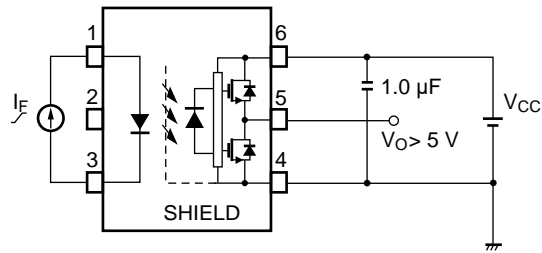

Fig. 8 t_{PLH}, t_{PHL}, t_r, t_f Test Circuit and Wave Forms

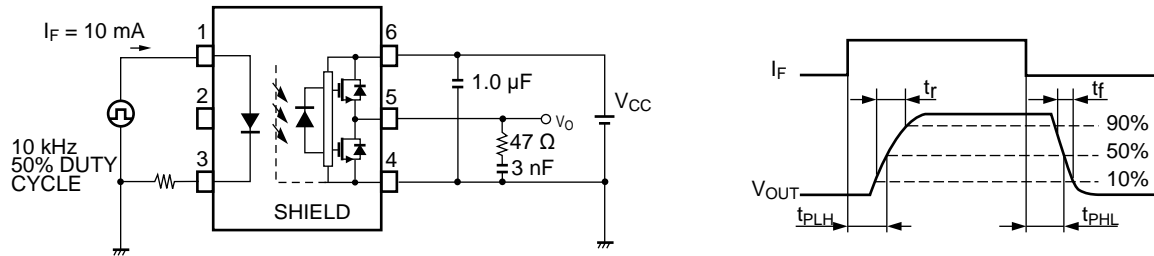
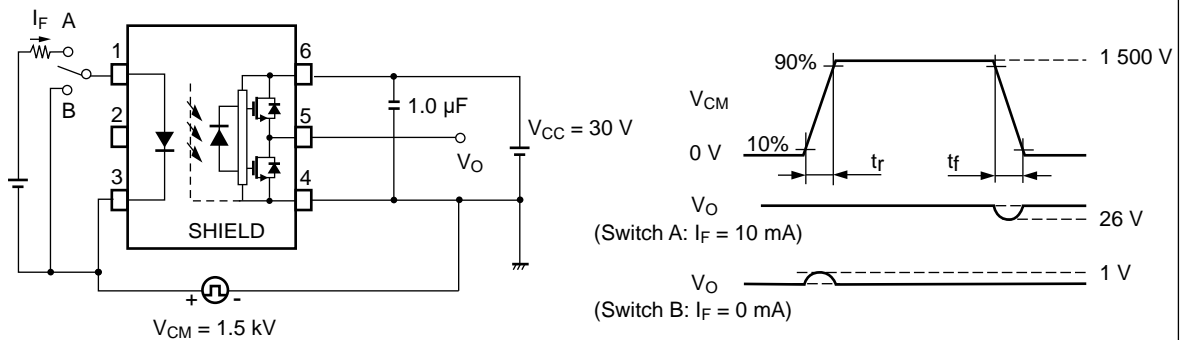
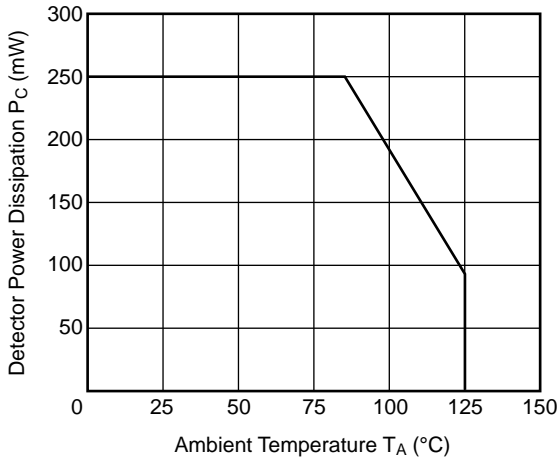

Fig. 9 CMR Test Circuit and Wave Forms



TYPICAL CHARACTERISTICS (T_A = 25 °C, unless otherwise specified)

DETECTOR POWER DISSIPATION vs. AMBIENT TEMPERATURE



DIODE POWER DISSIPATION vs. AMBIENT TEMPERATURE

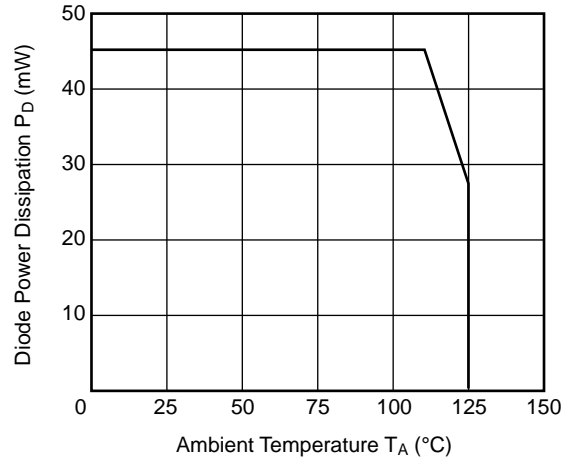

FORWARD CURRENT vs. FORWARD VOLTAGE

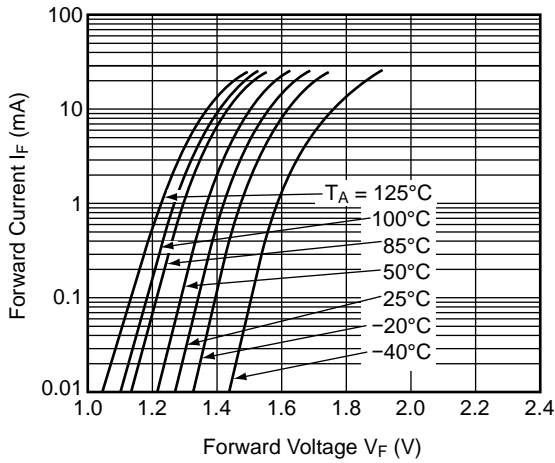

THRESHOLD INPUT CURRENT vs. AMBIENT TEMPERATURE

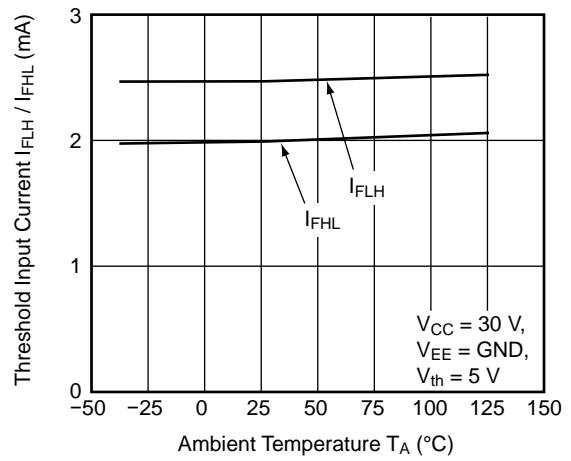

OUTPUT VOLTAGE vs. FORWARD CURRENT

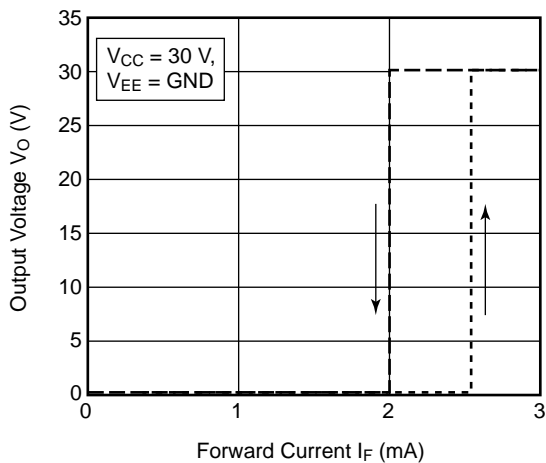

HIGH LEVEL OUTPUT CURRENT vs. HIGH LEVEL OUTPUT VOLTAGE - SUPPLY VOLTAGE

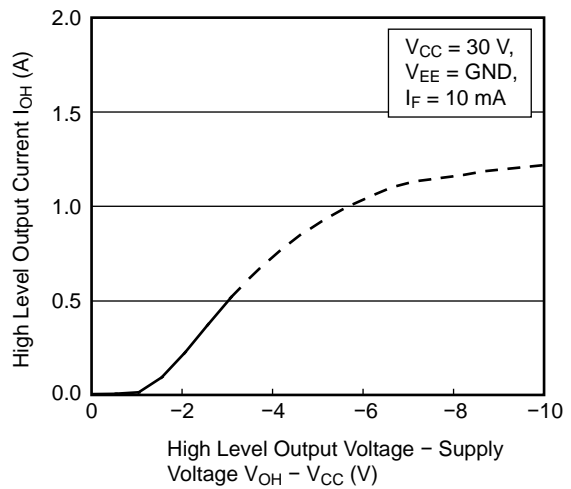

Remark The graphs indicate nominal characteristics.

LOW LEVEL OUTPUT CURRENT vs. LOW LEVEL OUTPUT VOLTAGE

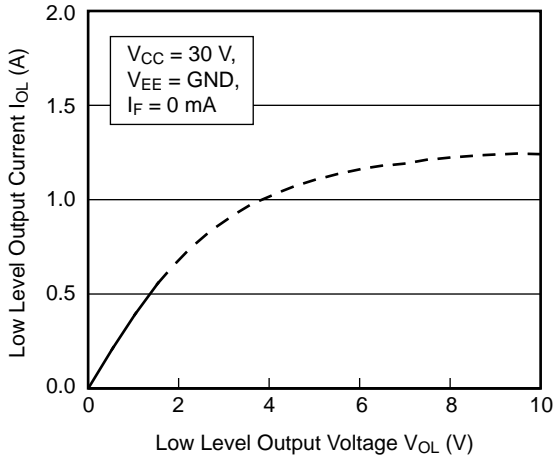

PROPAGATION DELAY TIME, PULSE WIDTH DISTORTION vs. FORWARD CURRENT

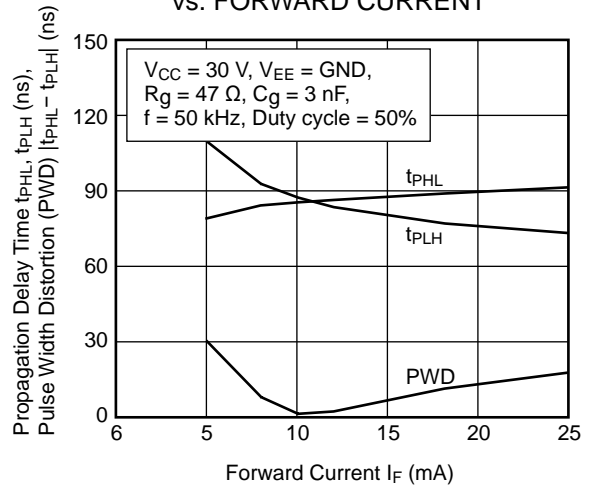

PROPAGATION DELAY TIME, PULSE WIDTH DISTORTION vs. SUPPLY VOLTAGE

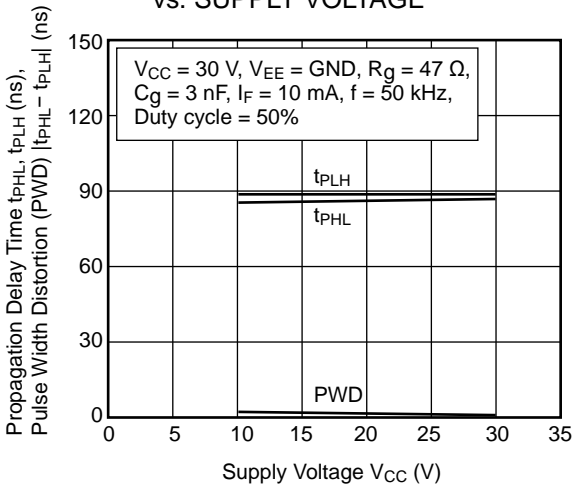

PROPAGATION DELAY TIME, PULSE WIDTH DISTORTION vs. LOAD CAPACITANCE

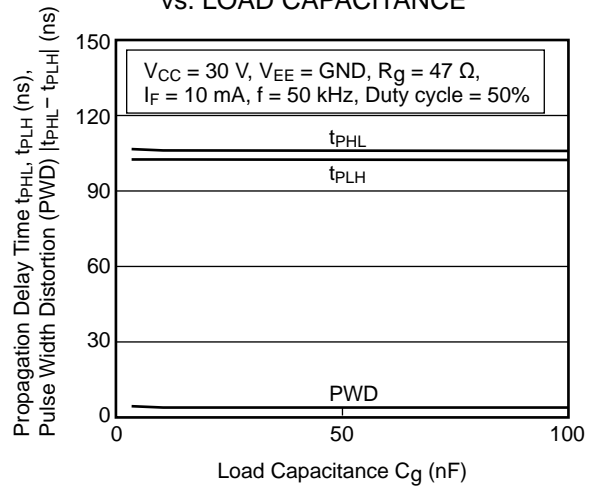

PROPAGATION DELAY TIME, PULSE WIDTH DISTORTION vs. LOAD RESISTANCE

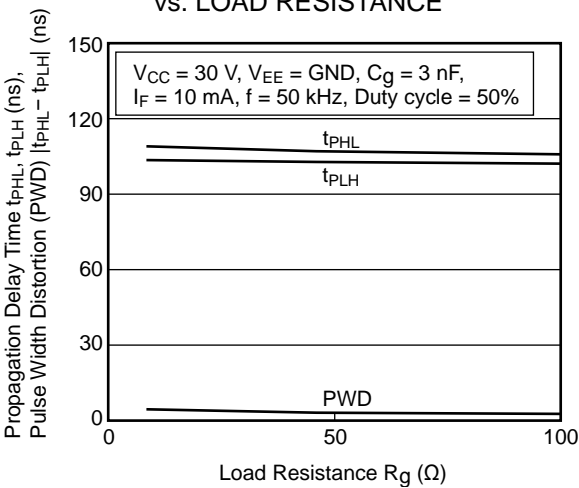

PROPAGATION DELAY TIME, PULSE WIDTH DISTORTION vs. AMBIENT TEMPERATURE

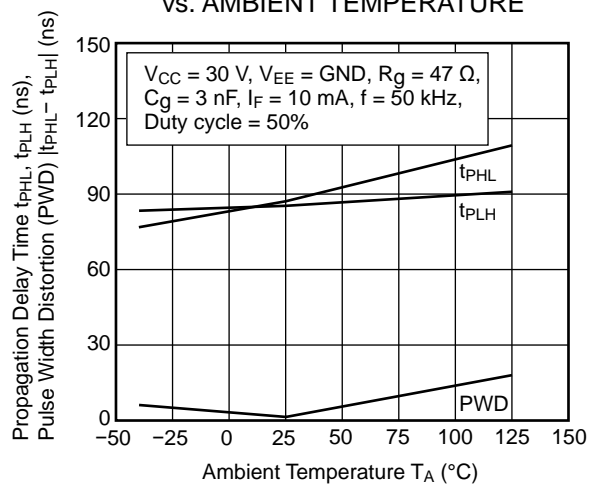

Remark The graphs indicate nominal characteristics.

SUPPLY CURRENT vs. AMBIENT TEMPERATURE

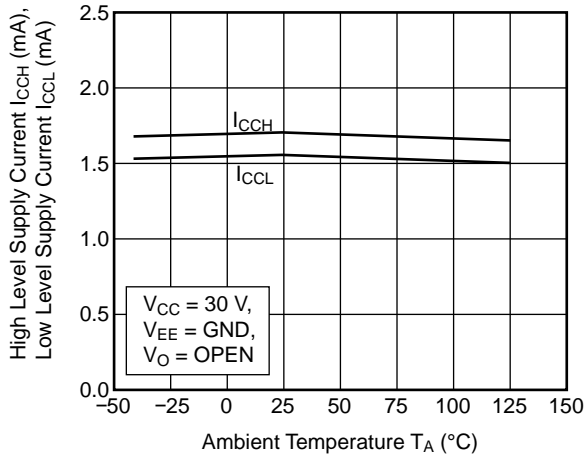

SUPPLY CURRENT vs. SUPPLY VOLTAGE

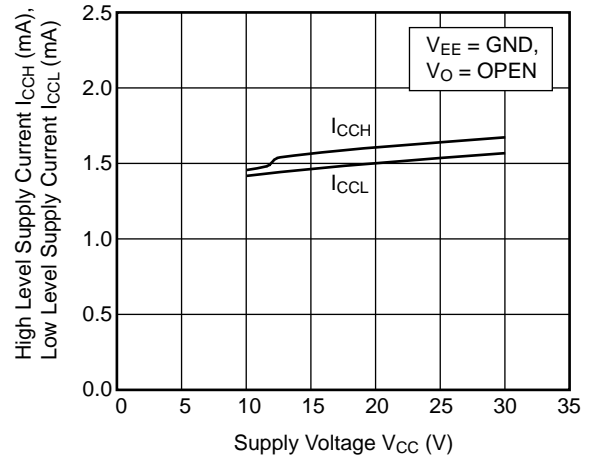

HIGH LEVEL OUTPUT VOLTAGE – SUPPLY VOLTAGE vs. AMBIENT TEMPERATURE

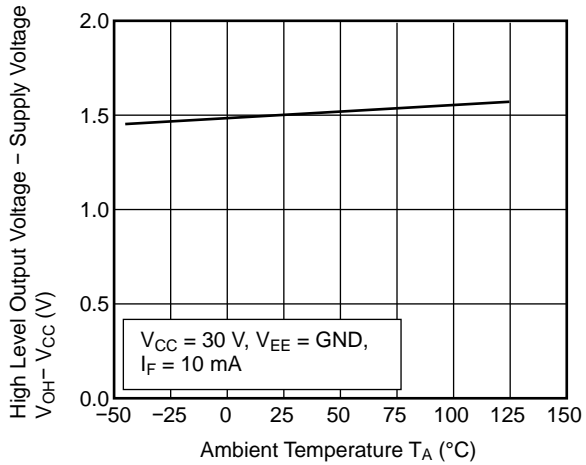

LOW LEVEL OUTPUT VOLTAGE vs. AMBIENT TEMPERATURE

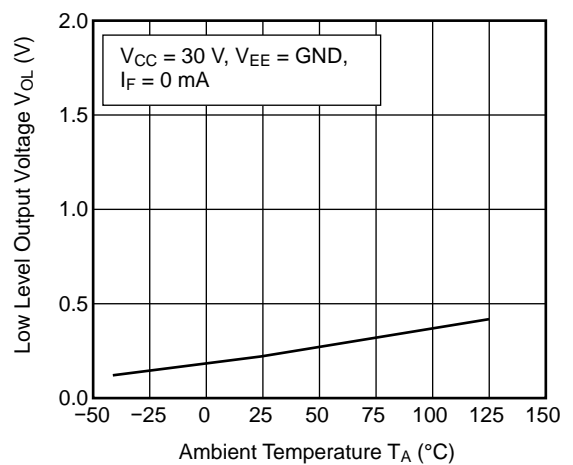

HIGH LEVEL OUTPUT CURRENT vs. AMBIENT TEMPERATURE

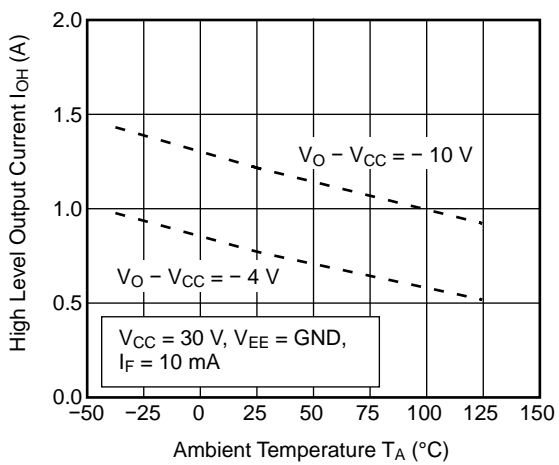

LOW LEVEL OUTPUT CURRENT vs. AMBIENT TEMPERATURE

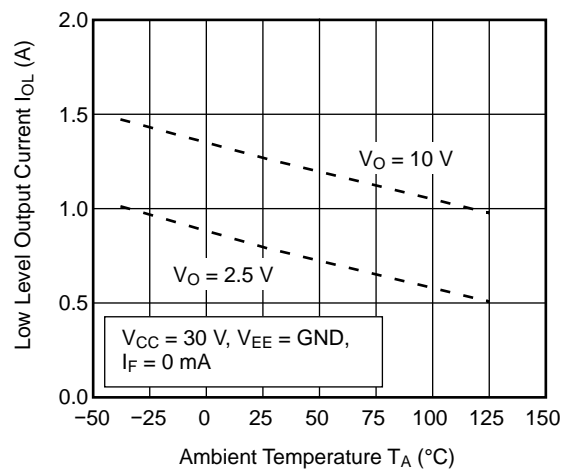

Remark The graphs indicate nominal characteristics.

OUTPUT VOLTAGE vs. SUPPLY VOLTAGE

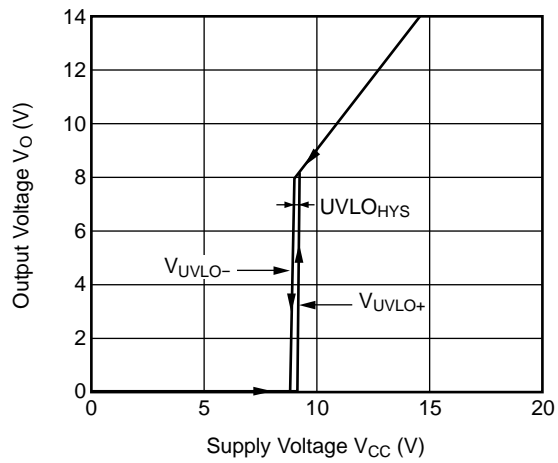

Remark The graphs indicate nominal characteristics.

TAPING SPECIFICATIONS (UNIT: mm)

Tape Direction

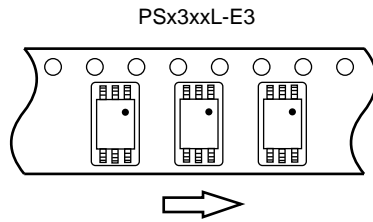

Outline and Dimensions (Tape)

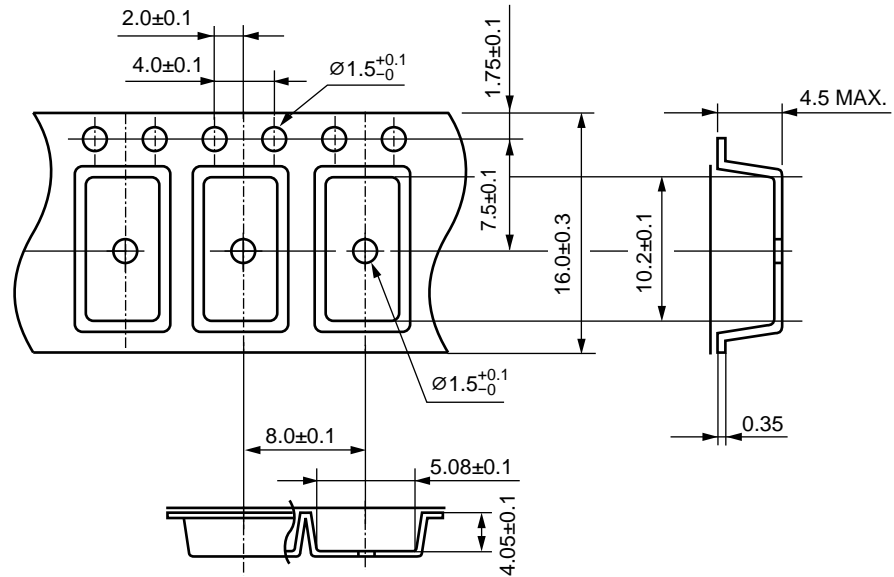

Outline and Dimensions (Reel)

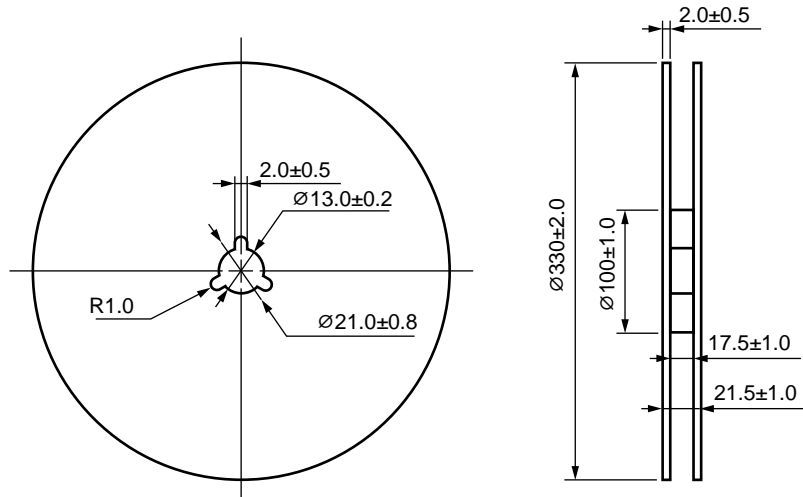

Packing: 2 000 pcs/reel

Tape Direction

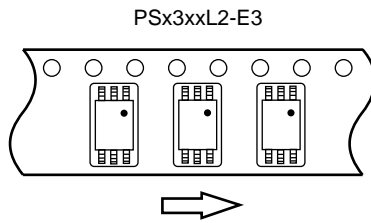

Outline and Dimensions (Tape)

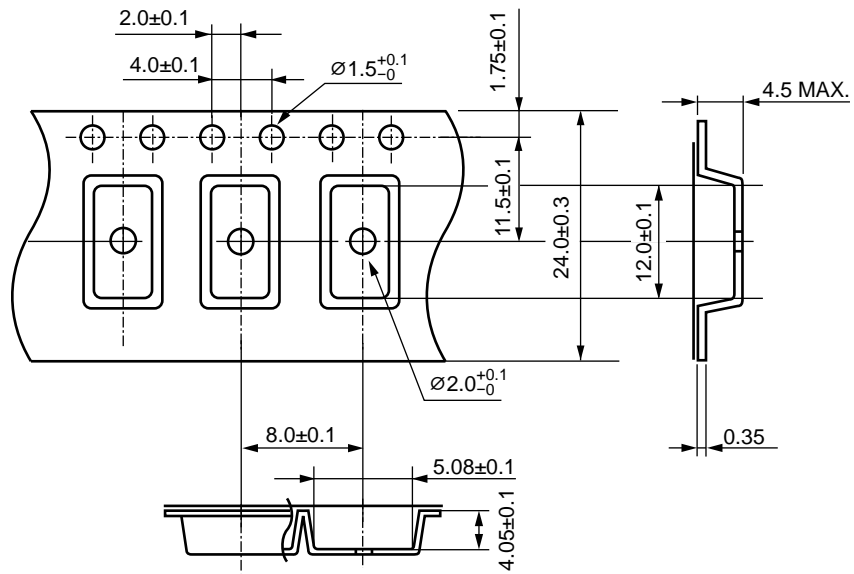

Outline and Dimensions (Reel)

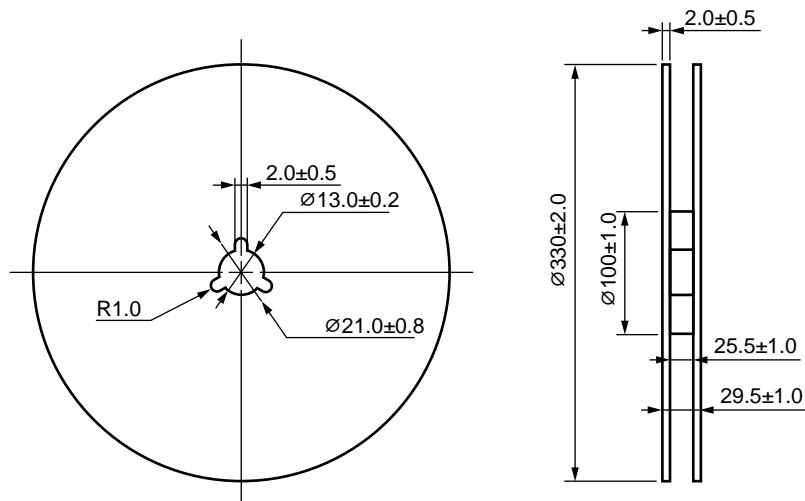

Packing: 2 000 pcs/reel

RECOMMENDED MOUNT PAD DIMENSIONS (UNIT: mm)

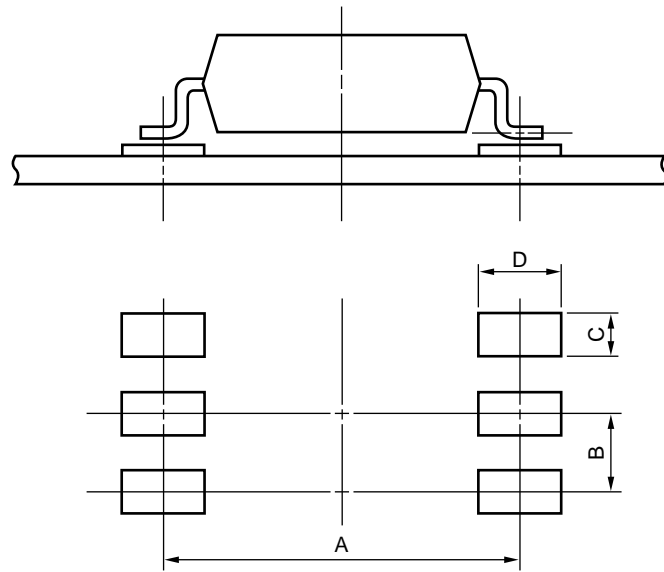

Part Number	Lead Bending	A	B	C	D
PSx3xxL	lead bending type (Gull-wing) for surface mount	9.2	1.27	0.8	2.2
PSx3xxL2	lead bending type (Gull-wing) for long creepage distance (surface mount)	10.2	1.27	0.8	2.2

Remark All dimensions in this figure must be evaluated before use.

NOTES ON HANDLING

1. Recommended soldering conditions

(1) Infrared reflow soldering

- Peak reflow temperature 260 °C or below (package surface temperature)
- Time of peak reflow temperature 10 seconds or less
- Time of temperature higher than 220 °C 60 seconds or less
- Time to preheat temperature from 120 to 180 °C 120 ± 30 s
- Number of reflows Three
- Flux Rosin flux containing small amount of chlorine
(The flux with a maximum chlorine content of 0.2 Wt% is recommended.)

Recommended Temperature Profile of Infrared Reflow

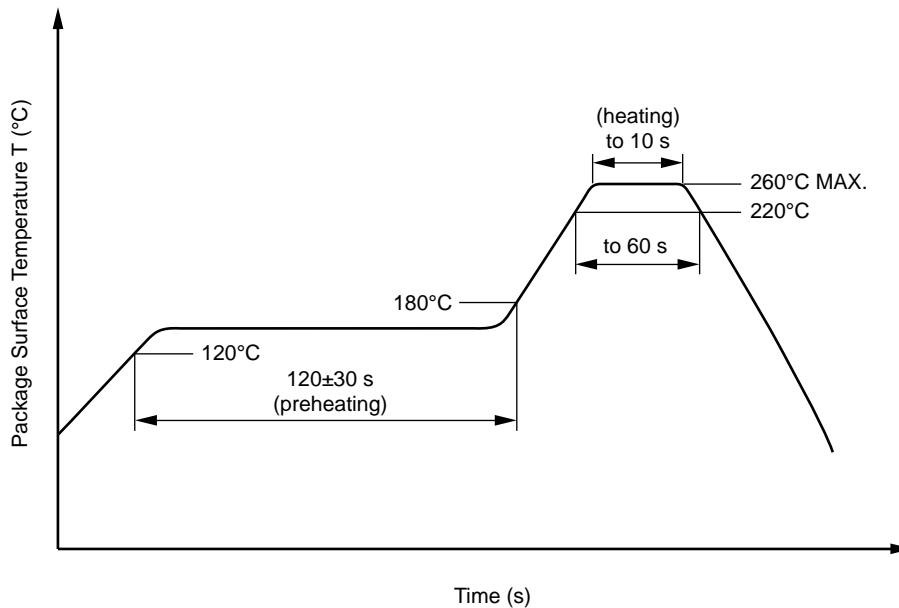

(2) Wave soldering

- Temperature 260 °C or below (molten solder temperature)
- Time 10 seconds or less
- Preheating conditions 120 °C or below (package surface temperature)
- Number of times One (Allowed to be dipped in solder including plastic mold portion.)
- Flux Rosin flux containing small amount of chlorine (The flux with a maximum chlorine content of 0.2 Wt% is recommended.)

(3) Soldering by Soldering Iron

- Peak Temperature (lead part temperature) 350 °C or below
- Time (each pins) 3 seconds or less
- Flux Rosin flux containing small amount of chlorine
(The flux with a maximum chlorine content of 0.2 Wt% is recommended.)

(a) Soldering of leads should be made at the point 1.5 to 2.0 mm from the root of the lead

(b) Please be sure that the temperature of the package would not be heated over 100 °C

(4) Cautions

- Flux Cleaning
Avoid cleaning with Freon based or halogen-based (chlorinated etc.) solvents.
- Do not use fixing agents or coatings containing halogen-based substances.

2. Cautions regarding noise

Be aware that when voltage is applied suddenly between the photocoupler's input and output at startup, the output transistor may enter the on state, even if the voltage is within the absolute maximum ratings.

USAGE CAUTIONS

1. This product is weak for static electricity by designed with high-speed integrated circuit so protect against static electricity when handling.
2. Board designing
 - (1) By-pass capacitor of more than 1.0 μ F is used between V_{CC} and GND near device. Also, ensure that the distance between the leads of the photocoupler and capacitor is no more than 10 mm.
 - (2) When designing the printed wiring board, ensure that the pattern of the IGBT collectors/emitters is not too close to the input block pattern of the photocoupler.
If the pattern is too close to the input block and coupling occurs, a sudden fluctuation in the voltage on the IGBT output side might affect the photocoupler's LED input, leading to malfunction or degradation of characteristics.
(If the pattern needs to be close to the input block, to prevent the LED from lighting during the off state due to the abovementioned coupling, design the input-side circuit so that the bias of the LED is reversed, within the range of the recommended operating conditions, and be sure to thoroughly evaluate operation.)
 - (3) Pin 2 (which is an NC*1 pin) can either be connected directly to the GND pin on the LED side or left open. Unconnected pins should not be used as a bypass for signals or for any other similar purpose because this may degrade the internal noise environment of the device.
Note: *1. NC: Non-Connection (No Connection).
3. Make sure the rise/fall time of the forward current is 0.5 μ s or less.
4. In order to avoid malfunctions, make sure the rise/fall slope of the supply voltage is 3 V/ μ s or less.
5. Avoid storage at a high temperature and high humidity.
6. Avoid cleaning with Freon based or halogen-based (chlorinated etc.) solvents.
7. Do not use fixing agents or coatings containing halogen-based substances.

SPECIFICATION OF VDE MARKS LICENSE DOCUMENT

Parameter	Symbol	Rating	Unit
Climatic test class (IEC 60068-1/DIN EN 60068-1)		40/125/21	
Dielectric strength maximum operating isolation voltage Test voltage (partial discharge test, procedure a for type test and random test) $U_{pr} = 1.6 \times U_{IORM}, P_d < 5 \text{ pC}$	U_{IORM} U_{pr}	1 130 1 808	V_{peak} V_{peak}
Test voltage (partial discharge test, procedure b for all devices) $U_{pr} = 1.875 \times U_{IORM}, P_d < 5 \text{ pC}$	U_{pr}	2 119	V_{peak}
Highest permissible overvoltage	U_{TR}	8 000	V_{peak}
Degree of pollution (IEC 60664-1/DIN EN 60664-1 (VDE 0110-1))		2	
Comparative tracking index (IEC 60112/DIN EN 60112 (VDE 0303-11))	CTI	175	
Material group (IEC 60664-1/DIN EN 60664-1 (VDE 0110-1))		III a	
Storage temperature range	T_{stg}	-55 to +150	°C
Operating temperature range	T_A	-40 to +125	°C
Isolation resistance, minimum value $V_{IO} = 500 \text{ V dc at } T_A = 25 \text{ °C}$ $V_{IO} = 500 \text{ V dc at } T_A \text{ MAX. at least } 100 \text{ °C}$	Ris MIN. Ris MIN.	10^{12} 10^{11}	Ω Ω
Safety maximum ratings (maximum permissible in case of fault, see thermal derating curve) Package temperature Current (input current I_F , $P_{si} = 0$) Power (output or total power dissipation) Isolation resistance $V_{IO} = 500 \text{ V dc at } T_A = T_{si}$	T_{si} I_{si} P_{si} Ris MIN.	175 400 700 10^9	°C mA mW Ω

Dependence of maximum safety ratings with package temperature

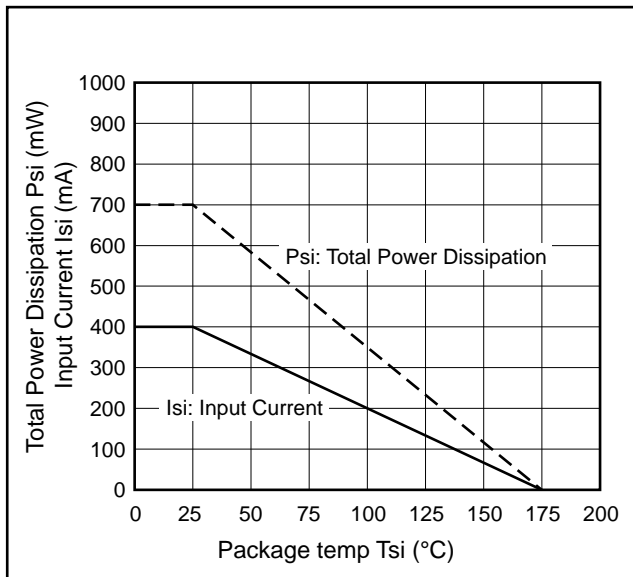

Method a) Destructive Test, Type and Sample Test

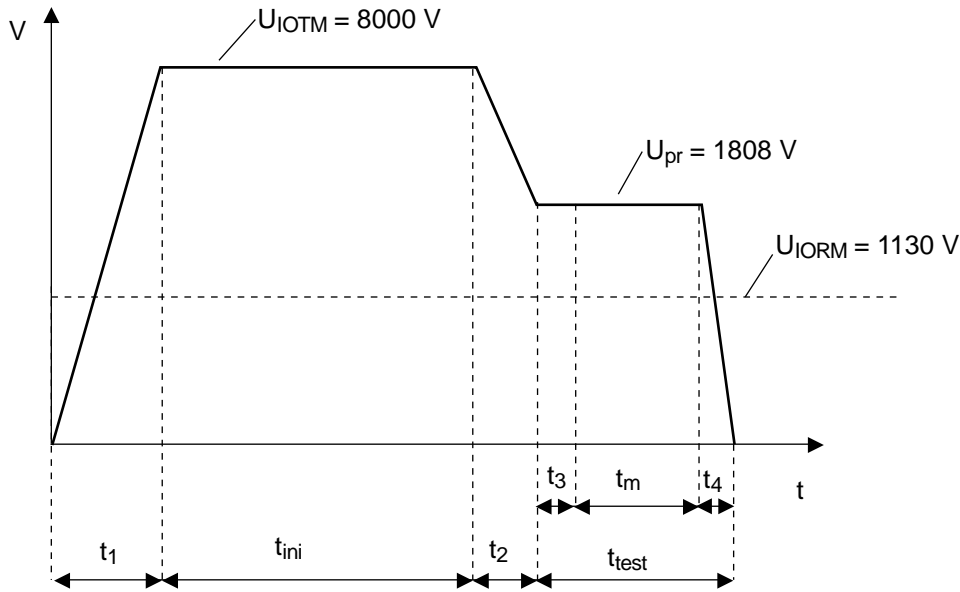

$t_1, t_2 = 1\text{ to }10\text{ sec}$
 $t_3, t_4 = 1\text{ sec}$
 $t_m(\text{PARTIAL DISCHARGE}) = 10\text{ sec}$
 $t_{test} = 12\text{ sec}$
 $t_{ini} = 60\text{ sec}$

Method b) Non-destructive Test, 100% Production Test

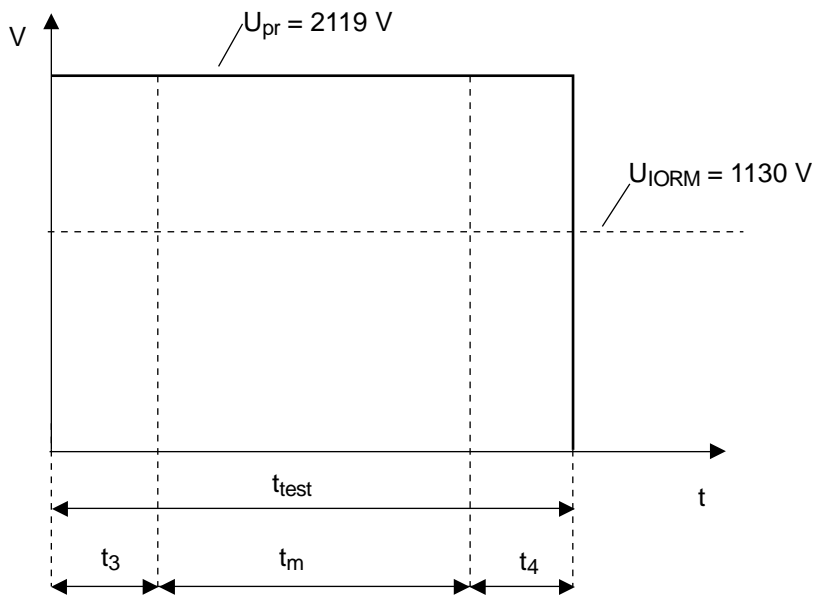

$t_3, t_4 = 0.1\text{ sec}$
 $t_m(\text{PARTIAL DISCHARGE}) = 1.0\text{ sec}$
 $t_{test} = 1.2\text{ sec}$

Caution	GaAs Products	<p>This product uses gallium arsenide (GaAs). GaAs vapor and powder are hazardous to human health if inhaled or ingested, so please observe the following points.</p> <ul style="list-style-type: none">• Follow related laws and ordinances when disposing of the product. If there are no applicable laws and/or ordinances, dispose of the product as recommended below.<ol style="list-style-type: none">1. Commission a disposal company able to (with a license to) collect, transport and dispose of materials that contain arsenic and other such industrial waste materials.2. Exclude the product from general industrial waste and household garbage, and ensure that the product is controlled (as industrial waste subject to special control) up until final disposal.• Do not burn, destroy, cut, crush, or chemically dissolve the product.• Do not lick the product or in any way allow it to enter the mouth.
----------------	---------------	--