

# PS9817A-1,-2

HIGH CMR, 10 Mbps OPEN COLLECTOR OUTPUT TYPE  
8-PIN SSOP (SO-8) HIGH-SPEED PHOTOCOUPLER

R08DS0259EJ0100  
Rev.1.00  
Dec 14, 2021

## DESCRIPTION

The PS9817A-1 and PS9817A-2 are active-low type high-speed photocouplers that use an AlGaAs light-emitting diode on the input side and a photodetector IC that includes a photodiode and a signal processor on the same chip on the output side.

The PS9817A-1 and PS9817A-2 are designed specifically for high common mode transient immunity (CMR) and low pulse width distortion. The PS9817A-2 is suitable for high density applications.

## FEATURES

- Pulse width distortion ( $|t_{PHL}-t_{PLH}| = 35 \text{ ns MAX.}$ )
- High common mode transient immunity ( $CM_H, CM_L = \pm 15 \text{ kV}/\mu\text{s MIN.}$ )
- 40 % reduction of mounting area (5-pin SOP  $\times$  2)
- High-speed (10 Mbps)
- High isolation voltage ( $BV = 2\,500 \text{ Vr.m.s.}$ )
- Open collector output
- Ordering number of tape product: PS9817A-1-F3 : 1 500 pcs/reel  
: PS9817A-2-F3 : 1 500 pcs/reel
- Pb-Free product
- Safety standards
  - UL : UL1577, Single protection
  - CSA : CAN/CSA-C22.2 No.62368-1, Basic insulation
  - VDE : DIN EN 60747-5-5 (Option)

## APPLICATIONS

- Measurement equipment
- PDP
- FA Network

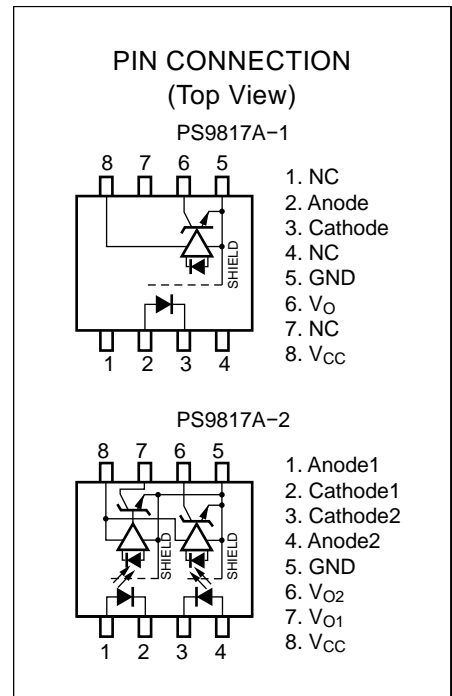

## TRUTH TABLE

LED	Output
ON	L
OFF	H

Start of mass production  
Sep.2006

**PACKAGE DIMENSIONS (UNIT: mm)**

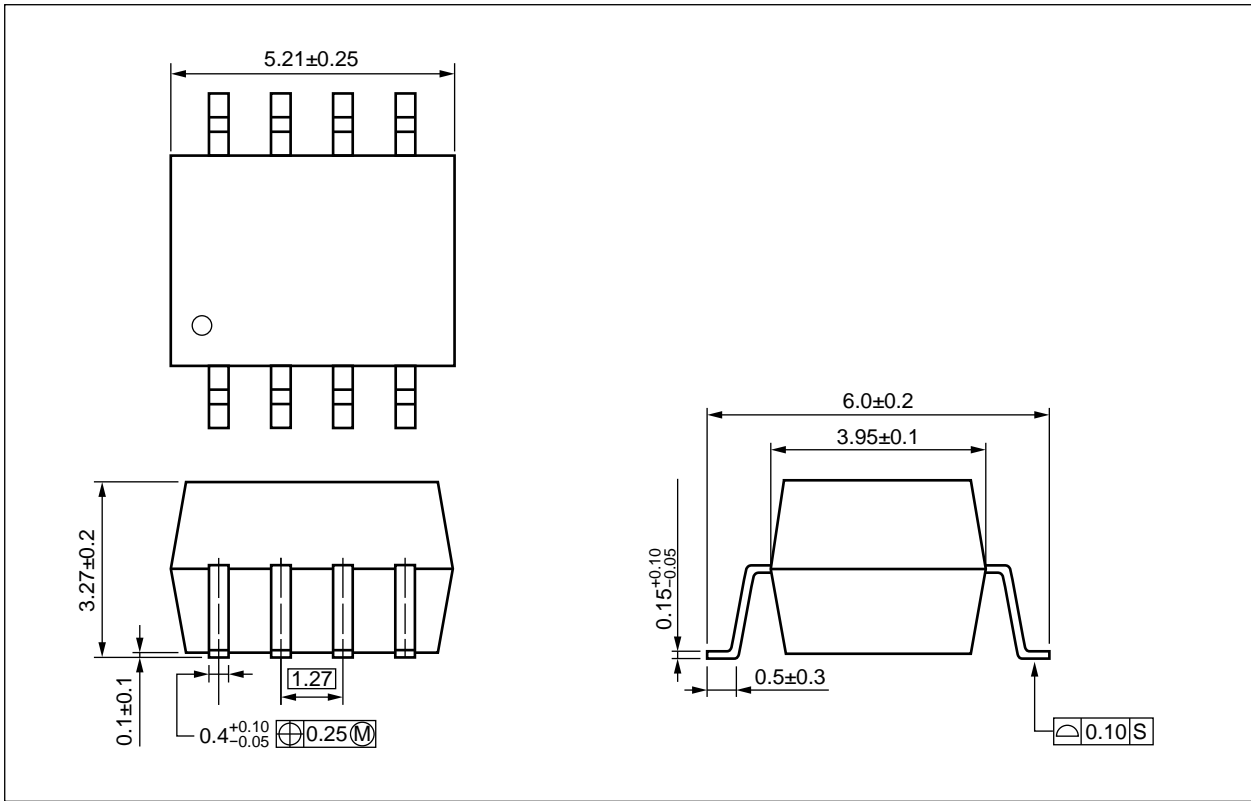

Weight: 0.14g (typ.)

**PHOTOCOUPLER CONSTRUCTION**

Parameter	Unit (MIN.)
Air Distance	4 mm
Creepage Distance	4 mm
Isolation Distance	0.2 mm

**MARKING EXAMPLE**

Ni/Pd/Au PLATING

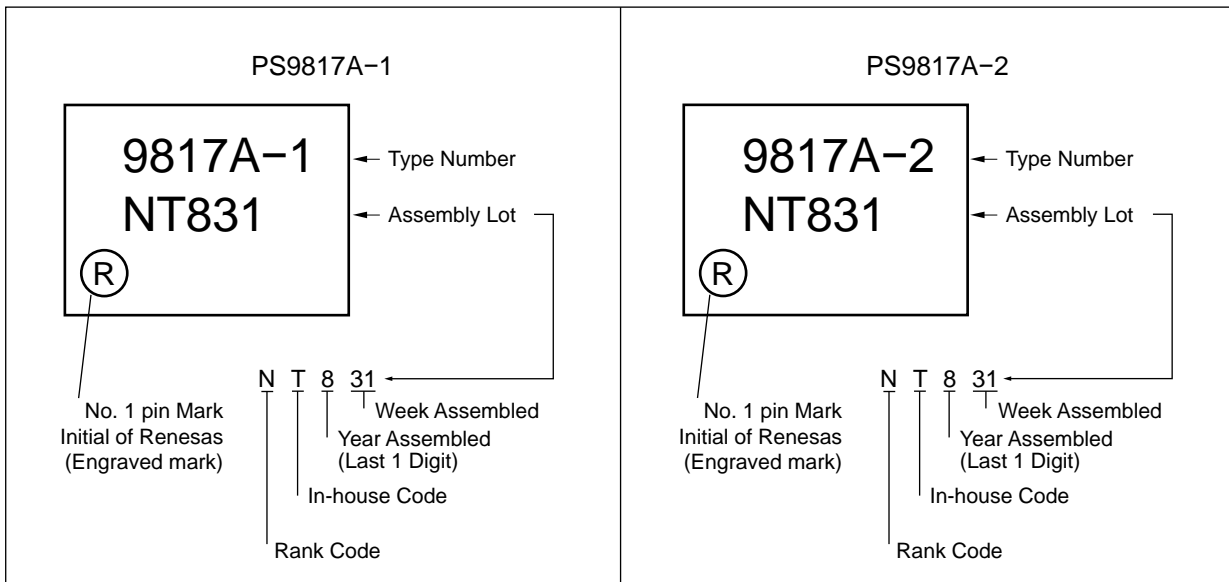

**ORDERING INFORMATION**

Part Number	Order Number	Solder Plating Specification	Packing Style	Safety Standard Approval	Application Part Number*1
PS9817A-1	PS9817A-1-AX	Pb-Free (Ni/Pd/Au)	20 pcs (Tape 20 pcs cut)	Standard products (UL, CSA approved)	PS9817A-1
PS9817A-1-F3	PS9817A-1-F3-AX		Embossed Tape 1 500 pcs/reel		
PS9817A-2	PS9817A-2-AX		20 pcs (Tape 20 pcs cut)		PS9817A-2
PS9817A-2-F3	PS9817A-2-F3-AX		Embossed Tape 1 500 pcs/reel		
PS9817A-1-V	PS9817A-1-V-AX		20 pcs (Tape 20 pcs cut)	UL, CSA, DIN EN 60747-5-5 approved	PS9817A-1
PS9817A-1-V-F3	PS9817A-1-V-F3-AX		Embossed Tape 1 500 pcs/reel		
PS9817A-2-V	PS9817A-2-V-AX		20 pcs (Tape 20 pcs cut)		PS9817A-2
PS9817A-2-V-F3	PS9817A-2-V-F3-AX		Embossed Tape 1 500 pcs/reel		

Notes\*: 1. For the application of the Safety Standard, following part number should be used.

**ABSOLUTE MAXIMUM RATINGS (T<sub>A</sub> = 25 °C, unless otherwise specified)**

Parameter		Symbol	Ratings		Unit
			PS9817A-1	PS9817-2	
Diode	Forward Current	I <sub>F</sub>	20*1	15*2	mA/ch
	Reverse Voltage	V <sub>R</sub>	5		V/ch
Detector	Supply Voltage	V <sub>CC</sub>	7		V
	Output Voltage	V <sub>O</sub>	7		V/ch
	Output Current	I <sub>O</sub>	25		mA/ch
	Power Dissipation *2	P <sub>C</sub>	40		mW/ch
Isolation Voltage *3		BV	2 500		Vr.m.s.
Operating Ambient Temperature		T <sub>A</sub>	- 40 to + 85		°C
Storage Temperature		T <sub>stg</sub>	- 55 to + 125		°C

- Notes\*: 1. Reduced to 0.3 mA/°C at T<sub>A</sub> = 60 °C or more.  
 2. Reduced to 0.1 mA/°C at T<sub>A</sub> = 60 °C or more.  
 3. Applies to output pin V<sub>O</sub> (collector pin). Reduced to 1.5 mW/°C at T<sub>A</sub> = 65 °C or more.  
 4. AC voltage for 1 minute at T<sub>A</sub> = 25 °C, RH = 60 % between input and output.  
 Pins 1-4 shorted together, 5-8 shorted together.

**RECOMMENDED OPERATING CONDITIONS**

Parameter	Symbol	MIN.	TYP.	MAX.	Unit
Low Level Input Voltage	V <sub>FL</sub>	0		0.8	V
High Level Input Current	I <sub>FH</sub>	6.3	10	12.5	mA
Supply Voltage	V <sub>CC</sub>	4.5		5.5	V
Pull-up Resistance	R <sub>L</sub>	330		4 k	Ω
TLL (R <sub>L</sub> = 1.0 kΩ, loads)	N			5	

ELECTRICAL CHARACTERISTICS ( $T_A = -40$  to  $+85$  °C, unless otherwise specified)

Parameter		Symbol	Conditions	MIN.	TYP. *1	MAX.	Unit	
Diode	Forward Voltage	$V_F$	$I_F = 10$ mA, $T_A = 25$ °C	1.4	1.65	1.8	V	
	Reverse Current	$I_R$	$V_R = 3.0$ V, $T_A = 25$ °C			10	μA	
	Terminal Capacitance	$C_i$	$V_F = 0$ V, $f = 1$ MHz, $T_A = 25$ °C		30		pF	
Detector	High Level Output Current	$I_{OH}$	$V_{CC} = V_O = 5.5$ V, $V_F = 0.8$ V		1	100	μA	
	Low Level Output Voltage *2	$V_{OL}$	$V_{CC} = 5.5$ V, $I_F = 5.0$ mA, $I_{OL} = 13$ mA		0.2	0.6	V	
	High Level Supply Current (PS9817A-1)	$I_{CCH}$	$V_{CC} = 5.5$ V, $I_F = 0$ mA, $V_O =$ open		4	7	mA	
	High Level Supply Current (PS9817A-2)				8	14		
	Low Level Supply Current (PS9817A-1)	$I_{CCL}$	$V_{CC} = 5.5$ V, $I_F = 10$ mA, $V_O =$ open		6	10		
	Low Level Supply Current (PS9817A-2)				12	20		
Coupled	Threshold Input Current (H → L)	$I_{FHL}$	$V_{CC} = 5.0$ V, $V_O = 0.8$ V, $R_L = 350$ Ω		2	5	mA	
	Isolation Resistance	$R_{I-O}$	$V_{I-O} = 1$ kV <sub>DC</sub> , $R_H = 40$ to $60$ %, $T_A = 25$ °C	$10^{11}$			Ω	
	Insulation Resistance (Input-Input), (PS9817A-2)	$R_{I-I}$	$V_{I-I} = 1$ kV <sub>DC</sub> , $R_H = 40$ to $60$ %, $T_A = 25$ °C	$10^{10}$			Ω	
	Isolation Capacitance	$C_{I-O}$	$V = 0$ V, $f = 1$ MHz, $T_A = 25$ °C		0.6		pF	
	Insulation Capacitance (Input-Input), (PS9817A-2)	$C_{I-I}$	$V = 0$ V, $f = 1$ MHz, $T_A = 25$ °C		0.3		pF	
	Propagation Delay Time (H → L) *3	$t_{PHL}$	$V_{CC} = 5.0$ V, $R_L = 350$ Ω, $I_F = 7.5$ mA	$T_A = 25$ °C		40	75	ns
							100	
	Propagation Delay Time (L → H) *3	$t_{PLH}$		$T_A = 25$ °C		45	75	
							100	
	Rise Time	$t_r$				20		
	Fall Time	$t_f$				5		
	Pulse Width Distortion (PWD) *3	$ t_{PHL} - t_{PLH} $				5	35	
	Propagation Delay Skew	$t_{PSK}$					40	
Common Mode Transient Immunity at High Level Output *4	$CM_H$	$V_{CC} = 5.0$ V, $R_L = 350$ Ω, $T_A = 25$ °C, $I_F = 0$ mA, $V_O > 2$ V, $V_{CM} = 1$ kV		15	20		kV/μs	
Common Mode Transient Immunity at Low Level Output *4	$CM_L$	$V_{CC} = 5.0$ V, $R_L = 350$ Ω, $T_A = 25$ °C, $I_F = 7.5$ mA, $V_O < 0.8$ V, $V_{CM} = 1$ kV		15	20			

Notes\*: 1 Typical values at  $T_A = 25$  °C

2 Because  $V_{OL}$  of 2 V or more may be output when LED current input and when output supply of  $V_{CC} = 2.6$  V or less, it is important to confirm the characteristics (operation with the power supply on and off) during design, before using this device.

3. Test circuit for propagation delay time

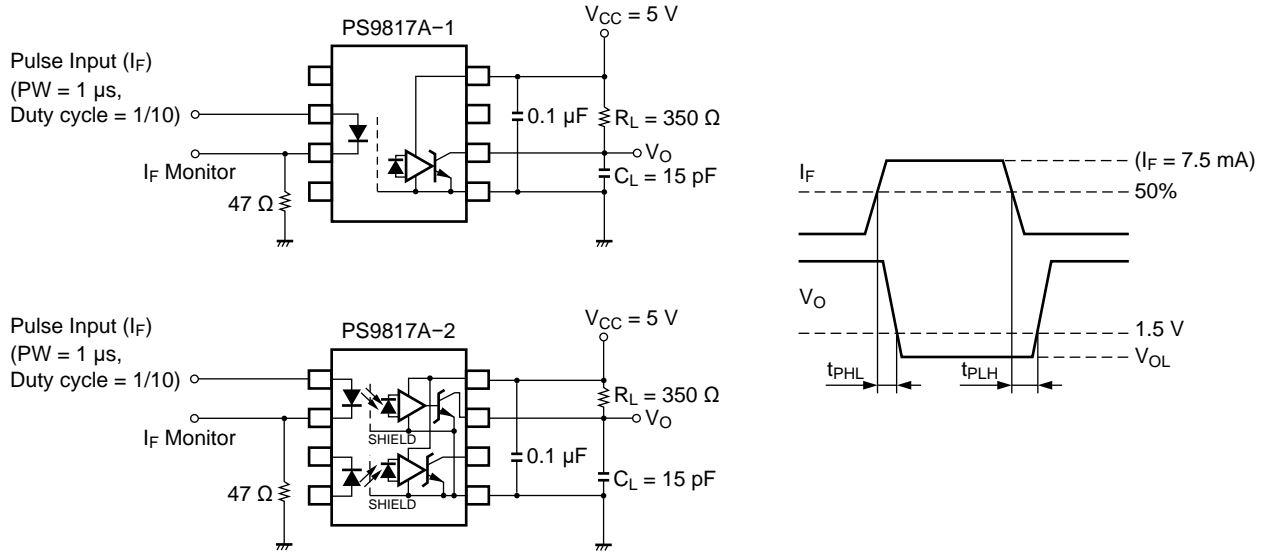

Remark: C<sub>L</sub> includes probe and stray wiring capacitance.

4. Test circuit for common mode transient immunity

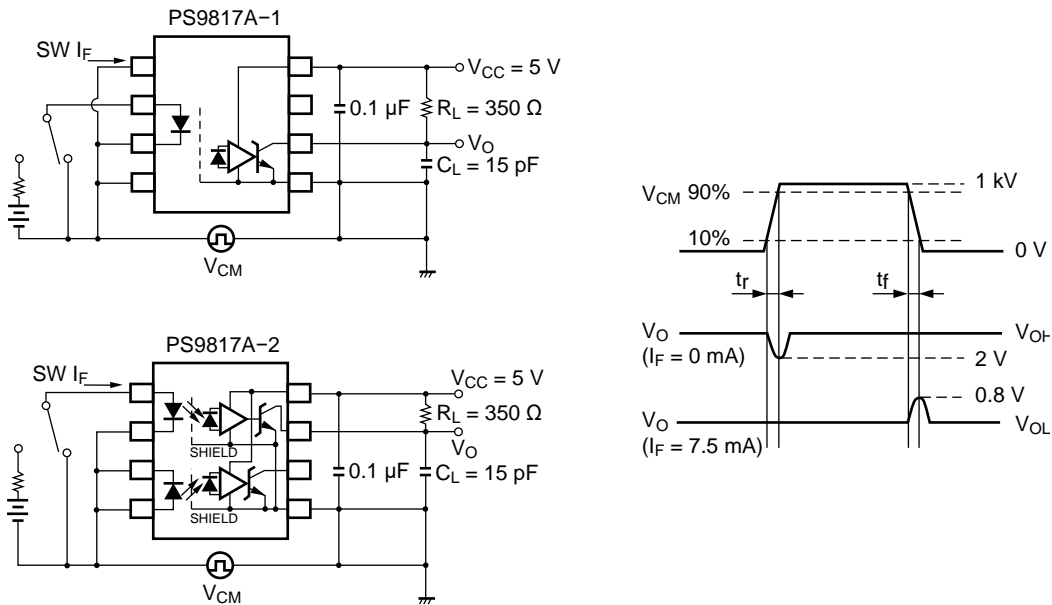

Remark: C<sub>L</sub> includes probe and stray wiring capacitance.

**USAGE CAUTIONS**

1. This product is weak for static electricity by designed with high-speed integrated circuit so protect against static electricity when handling.
2. By-pass capacitor of 0.1 μF is used between V<sub>CC</sub> and GND near device. Also, ensure that the distance between the leads of the photocoupler and capacitor is no more than 10 mm.
3. Avoid storage at a high temperature and high humidity.
4. Avoid cleaning with Freon based or halogen-based (chlorinated etc.) solvents.
5. Do not use fixing agents or coatings containing halogen-based substances.

**TYPICAL CHARACTERISTICS (T<sub>A</sub> = 25 °C unless otherwise specified)**

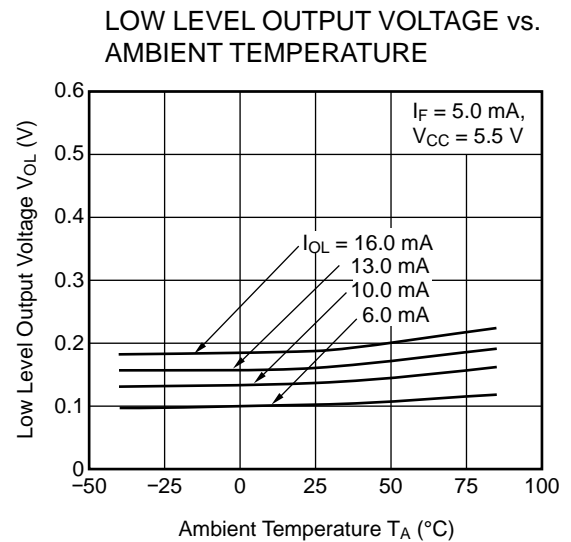
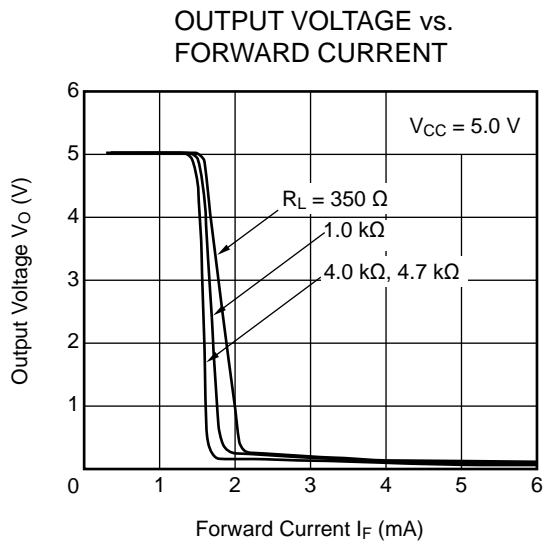
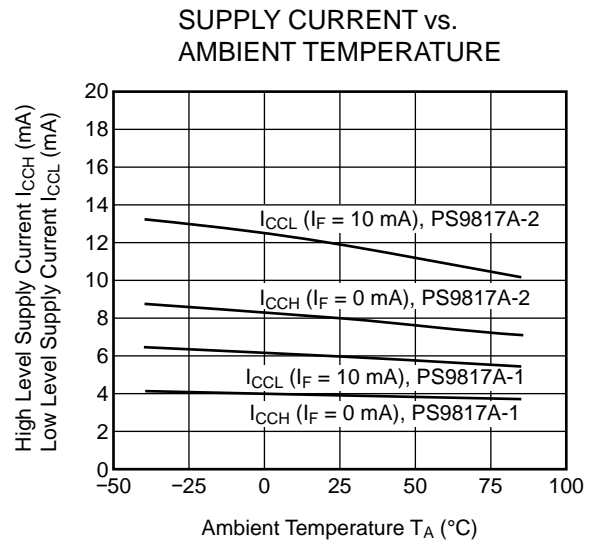
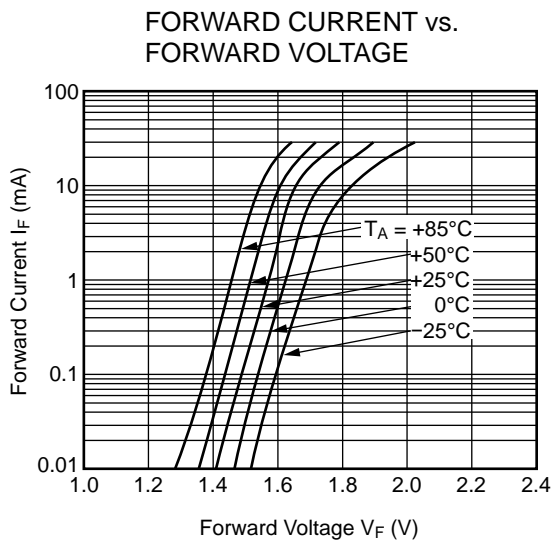
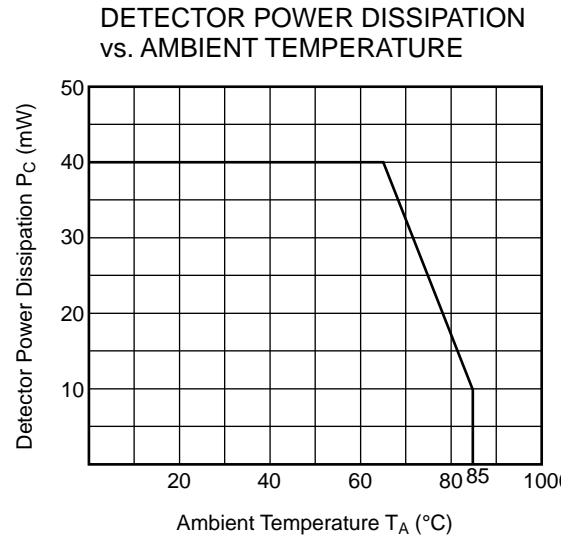
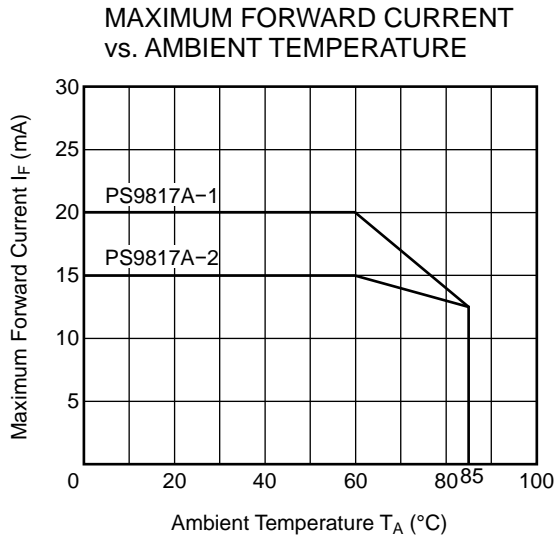

Remark The graphs indicate nominal characteristics.

THRESHOLD INPUT CURRENT vs. AMBIENT TEMPERATURE

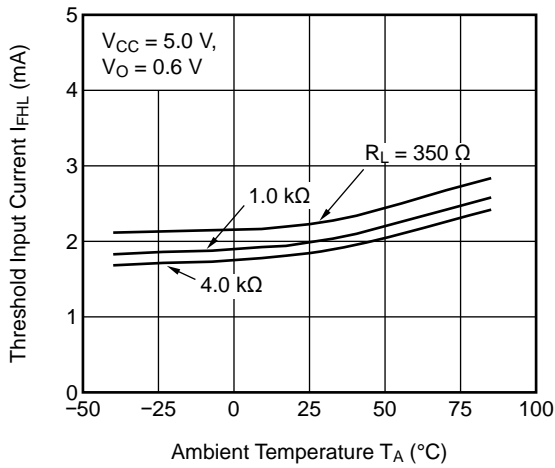

PROPAGATION DELAY TIME vs. AMBIENT TEMPERATURE

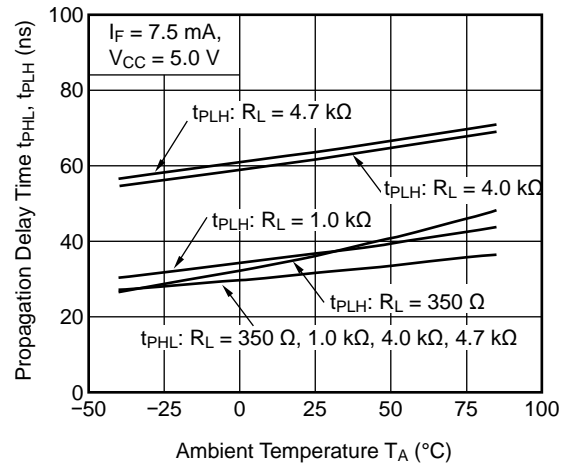

PULSE WIDTH DISTORTION vs. AMBIENT TEMPERATURE

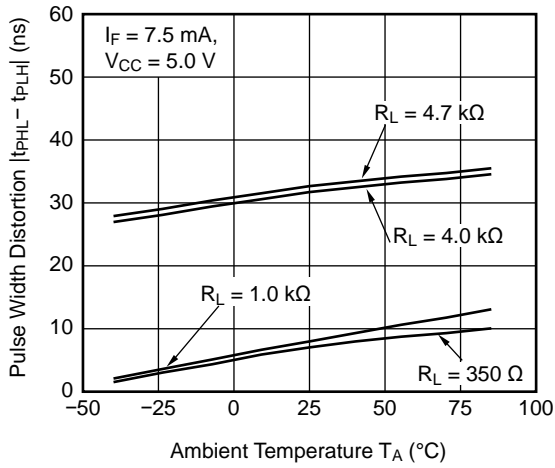

PROPAGATION DELAY TIME vs. FORWARD CURRENT

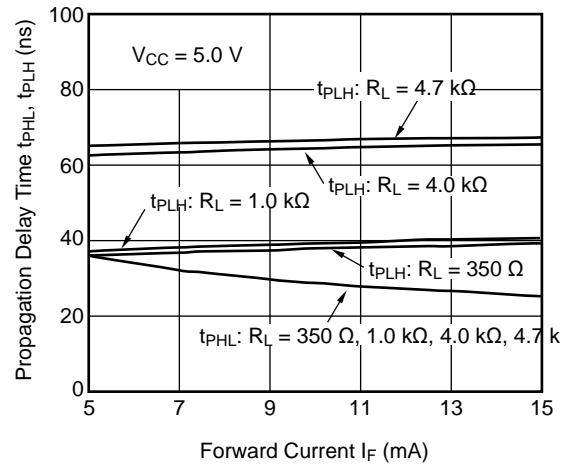

Remark The graphs indicate nominal characteristics.

TAPING SPECIFICATIONS (UNIT: mm)

Taping Direction

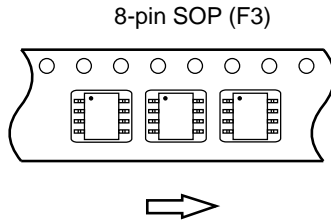

Outline and Dimensions (Tape)

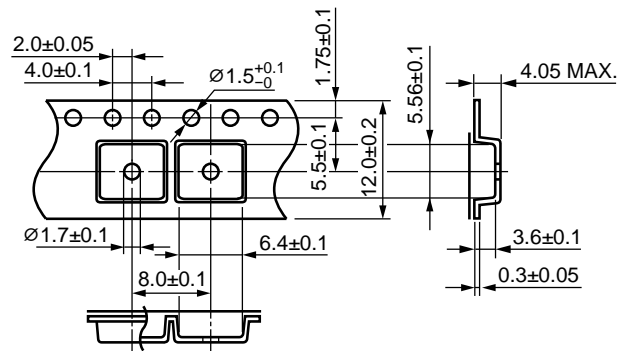

Outline and Dimensions (Reel)

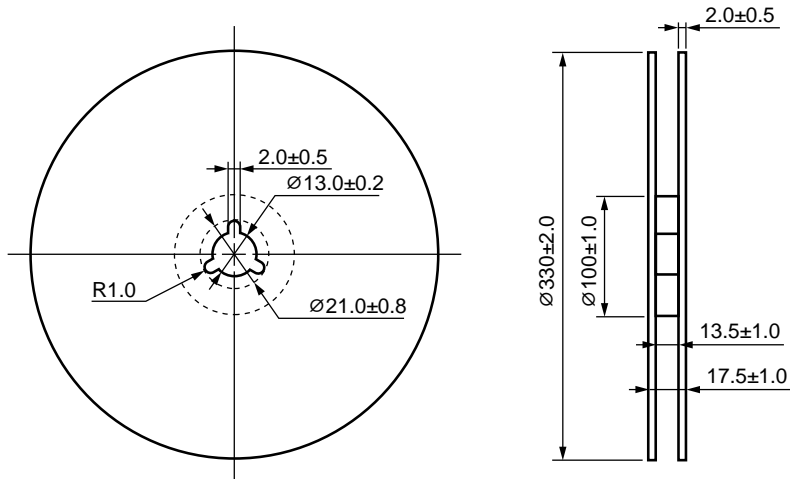

Packing: 1 500 pcs/reel



RECOMMENDED MOUNT PAD DIMENSIONS (UNIT: mm)

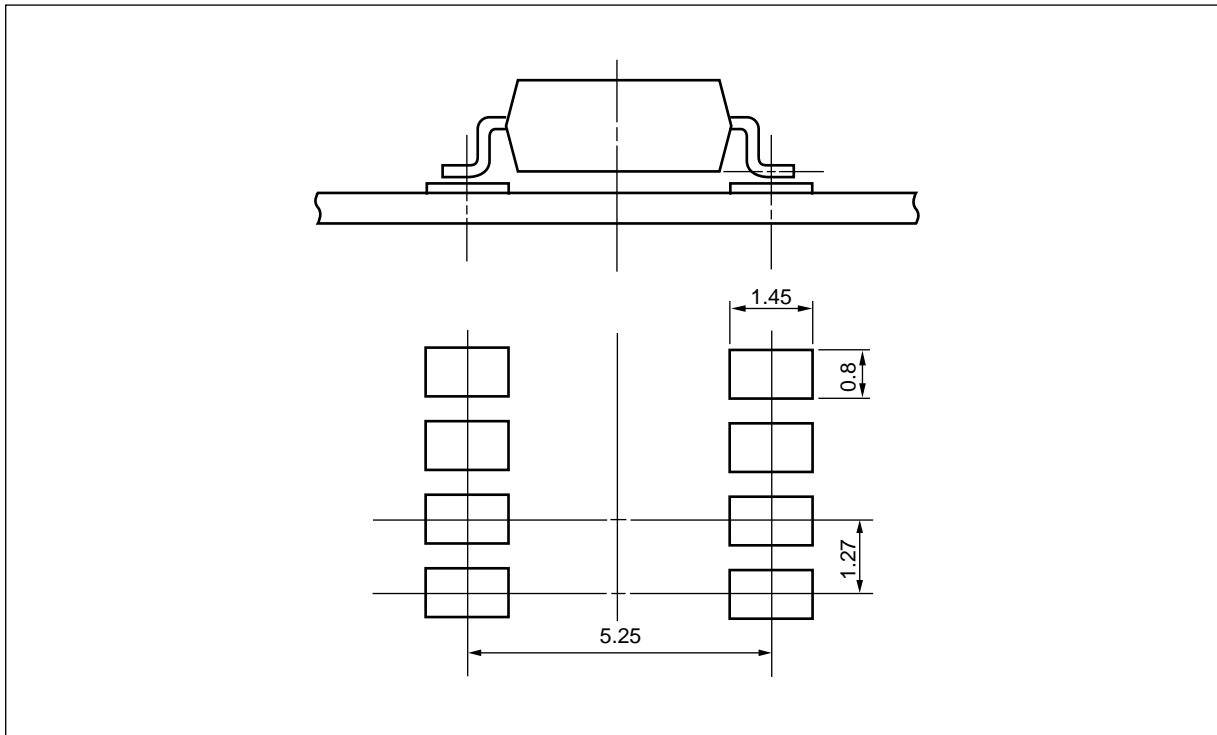

Remark All dimensions in this figure must be evaluated before use.

**NOTES ON HANDLING**

1. Recommended soldering conditions

(1) Infrared reflow soldering

- Peak reflow temperature 260 °C or below (package surface temperature)
- Time of peak reflow temperature 10 seconds or less
- Time of temperature higher than 220 °C 60 seconds or less
- Time to preheat temperature from 120 to 180 °C 120 ± 30 s
- Number of reflows Three
- Flux Rosin flux containing small amount of chlorine (The flux with a maximum chlorine content of 0.2 Wt% is recommended.)

Recommended Temperature Profile of Infrared Reflow

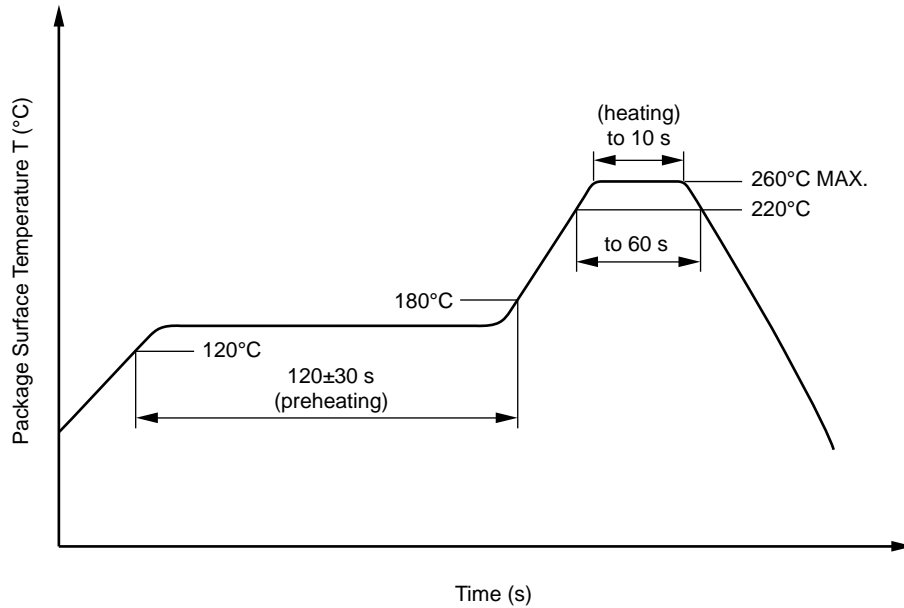

(2) Wave soldering

- Temperature 260 °C or below (molten solder temperature)
- Time 10 seconds or less
- Preheating conditions 120 °C or below (package surface temperature)
- Number of times One (Allowed to be dipped in solder including plastic mold portion.)
- Flux Rosin flux containing small amount of chlorine (The flux with a maximum chlorine content of 0.2 Wt% is recommended.)

(3) Soldering by Soldering Iron

- Peak Temperature (lead part temperature) 350 °C or below
- Time (each pins) 3 seconds or less
- Flux Rosin flux containing small amount of chlorine (The flux with a maximum chlorine content of 0.2 Wt% is recommended.)

- (a) Soldering of leads should be made at the point 1.5 to 2.0 mm from the root of the lead
- (b) Please be sure that the temperature of the package would not be heated over 100 °C

(4) Cautions

- Flux Cleaning  
Avoid cleaning with Freon based or halogen-based (chlorinated etc.) solvents.
- Do not use fixing agents or coatings containing halogen-based substances.

2. Cautions regarding noise

Be aware that when voltage is applied suddenly between the photocoupler's input and output or between collector-emitters at startup, the output transistor may enter the on state, even if the voltage is within the absolute maximum ratings.

**SPECIFICATION OF VDE MARKS LICENSE DOCUMENT**

Parameter	Symbol	Rating	Unit
Climatic test class (IEC 60068-1/DIN EN 60068-1)		40/85/21	
Dielectric strength maximum operating isolation voltage Test voltage (partial discharge test, procedure a for type test and random test) $U_{pr} = 1.6 \times U_{IORM.}, P_d < 5 \text{ pC}$	$U_{IORM}$ $U_{pr}$	566 905	$V_{peak}$ $V_{peak}$
Test voltage (partial discharge test, procedure b for all devices) $U_{pr} = 1.875 \times U_{IORM.}, P_d < 5 \text{ pC}$	$U_{pr}$	1 061	$V_{peak}$
Highest permissible overvoltage	$U_{IOTM}$	4 000	$V_{peak}$
Degree of pollution (IEC 60664-1/DIN EN 60664-1 (VDE 0110-1))		2	
Comparative tracking index (IEC 60112/DIN EN 60112 (VDE 0303-11))	CTI	175	
Material group (IEC 60664-1/DIN EN 60664-1 (VDE 0110-1))		III a	
Storage temperature range	$T_{stg}$	- 55 to +125	°C
Operating temperature range	$T_A$	- 40 to +85	°C
Isolation resistance, minimum value $V_{IO} = 500 \text{ V dc at } T_A = 25 \text{ °C}$ $V_{IO} = 500 \text{ V dc at } T_A \text{ MAX. at least } 100 \text{ °C}$	Ris MIN. Ris MIN.	$10^{12}$ $10^{11}$	$\Omega$ $\Omega$
Safety maximum ratings (maximum permissible in case of fault, see thermal derating curve) Package temperature Current (input current $I_F$ , $P_{si} = 0$ ) Power (output or total power dissipation) Isolation resistance $V_{IO} = 500 \text{ V dc at } T_A = T_{si}$	$T_{si}$ $I_{si}$ $P_{si}$ Ris MIN.	150 150 600 $10^9$	°C mA mW $\Omega$

**Dependence of maximum safety ratings with package temperature**

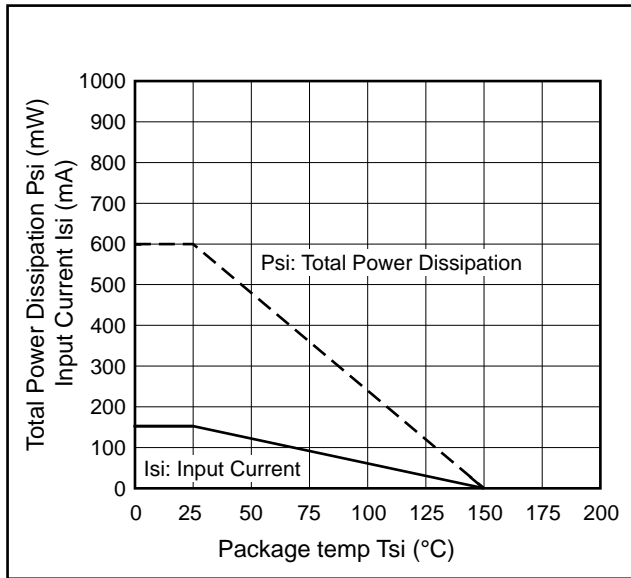

**Method a) Destructive Test, Type and Sample Test**

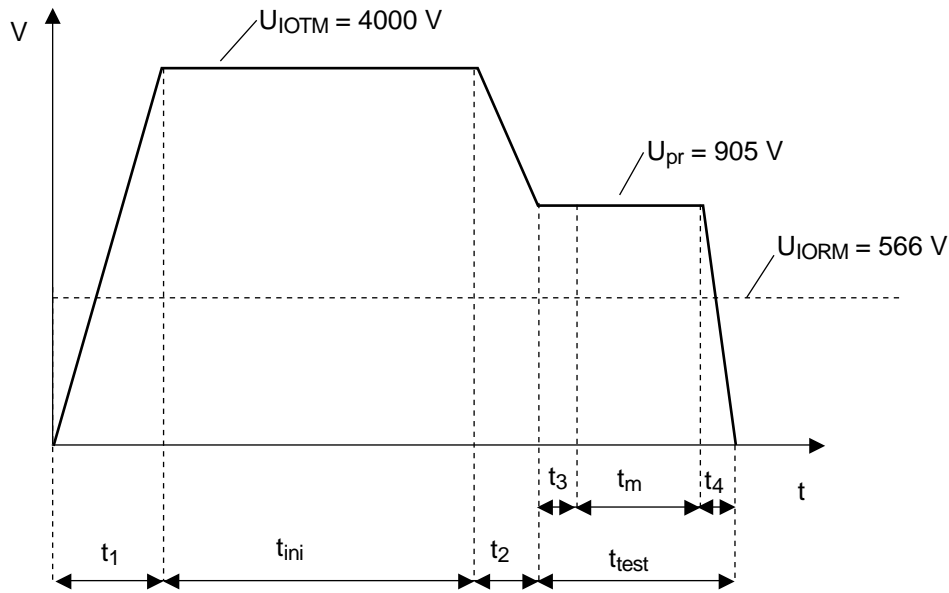

$t_1, t_2 = 1 \text{ to } 10 \text{ sec}$   
 $t_3, t_4 = 1 \text{ sec}$   
 $t_m(\text{PARTIAL DISCHARGE}) = 10 \text{ sec}$   
 $t_{\text{test}} = 12 \text{ sec}$   
 $t_{\text{ini}} = 60 \text{ sec}$

**Method b) Non-destructive Test, 100% Production Test**

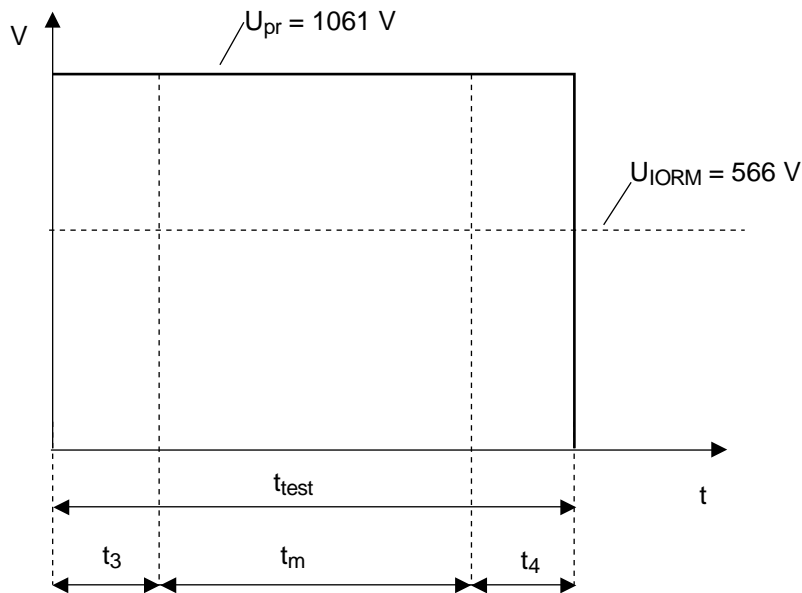

$t_3, t_4 = 0.1 \text{ sec}$   
 $t_m(\text{PARTIAL DISCHARGE}) = 1.0 \text{ sec}$   
 $t_{\text{test}} = 1.2 \text{ sec}$

<b>Caution</b>	GaAs Products	<p>This product uses gallium arsenide (GaAs). GaAs vapor and powder are hazardous to human health if inhaled or ingested, so please observe the following points.</p> <ul style="list-style-type: none"><li>• Follow related laws and ordinances when disposing of the product. If there are no applicable laws and/or ordinances, dispose of the product as recommended below.<ol style="list-style-type: none"><li>1. Commission a disposal company able to (with a license to) collect, transport and dispose of materials that contain arsenic and other such industrial waste materials.</li><li>2. Exclude the product from general industrial waste and household garbage, and ensure that the product is controlled (as industrial waste subject to special control) up until final disposal.</li></ol></li><li>• Do not burn, destroy, cut, crush, or chemically dissolve the product.</li><li>• Do not lick the product or in any way allow it to enter the mouth.</li></ul>
----------------	---------------	--

All trademarks and registered trademarks are the property of their respective owners.