

# PS9905

R08DS0058EJ0200

2.5 A OUTPUT CURRENT, HIGH CMR, IGBT GATE DRIVE, 8-PIN LSDIP PHOTOCOUPLER  
FOR CREEPAGE DISTANCE OF 15 mm

Rev.2.00  
Jun. 30, 2021

## DESCRIPTION

The PS9905 is optically coupled isolator containing an AlGaAs LED on the input side and a photo diode, a signal processing circuit and a power output transistor on the output side on one chip.

## FEATURES

- Long creepage distance (15 mm MIN.)
- Large peak output current (2.5 A MAX., 2.0 A MIN.)
- High speed switching ( $t_{PLH}$ ,  $t_{PHL}$  = 0.15  $\mu$ s MAX.)
- UVLO (Under Voltage Lock Out) protection with hysteresis
- High common mode transient immunity ( $CM_H$ ,  $CM_L$  =  $\pm$  25 kV/ $\mu$ s MIN.)
- 8-pin LSDIP (Long Creepage SDIP) type
- Embossed tape product: PS9905-F3: 1 000 pcs/reel
- Pb-Free Product
- Safety standards
  - UL approved: UL1577, Double protection
  - CSA approved: CAN/CSA-C22.2 No.62368-1, Reinforced insulation
  - SEMKO approved (Creepage Distance:14.5 mm \*): EN 62368-1, IEC 62368-1, Reinforced insulation  
\* Creepage Distance:15 mm – in process
  - VDE approved: DIN EN 60747-5-5 (Option)

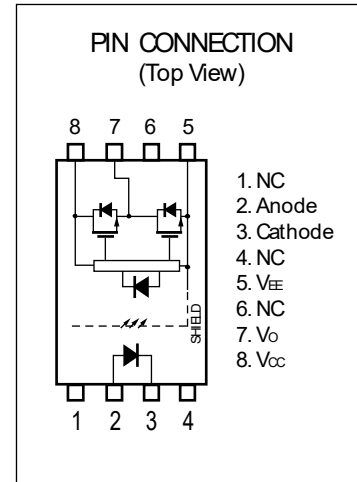

## APPLICATIONS

- IGBT, Power MOS FET Gate Driver
- Industrial inverter
- Solar inverter

Start of mass production  
Jun.2012

PACKAGE DIMENSIONS (UNIT: mm)

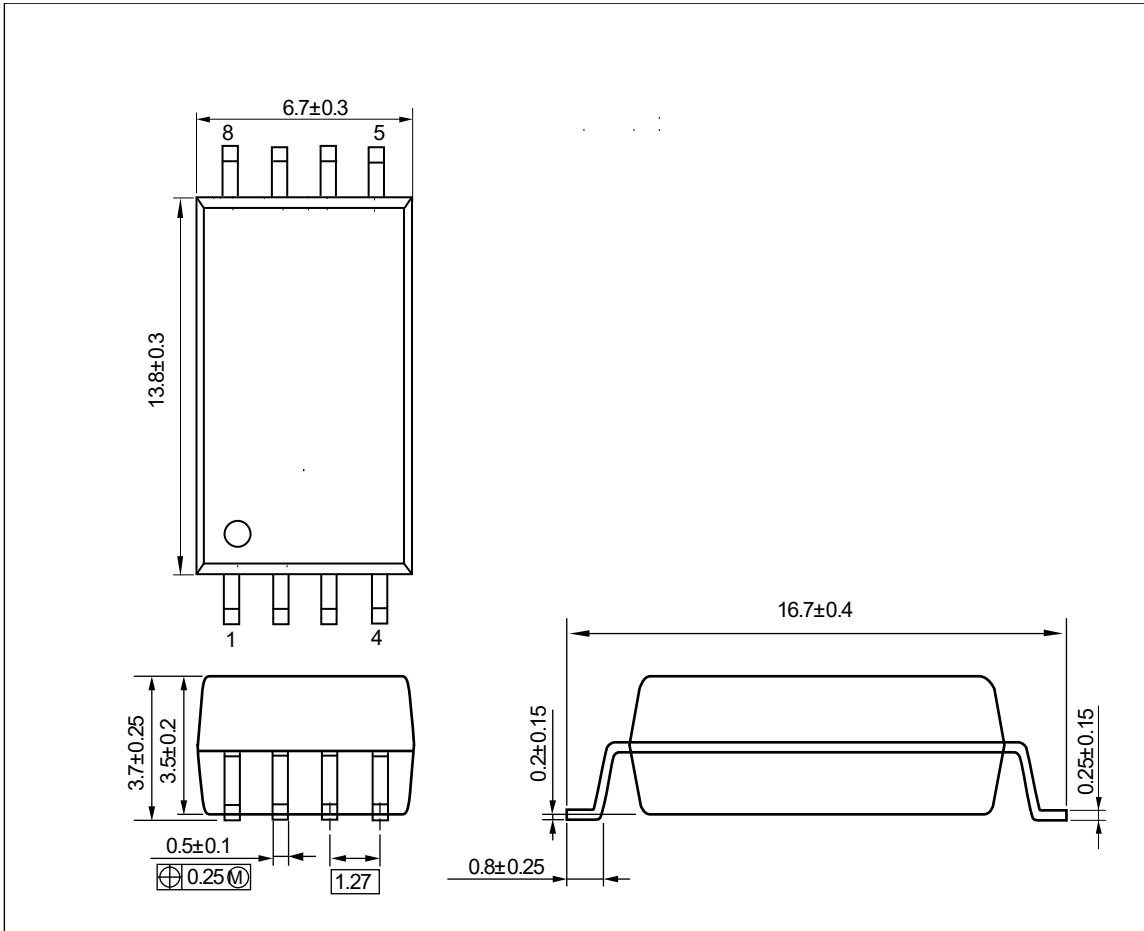

Weight: 0.642g (typ.)

PHOTOCOUPLER CONSTRUCTION

Parameter	MIN.
Air Distance	14.5 mm
Creepage Distance	15 mm
Isolation Distance	0.4 mm

FUNCTIONAL DIAGRAM

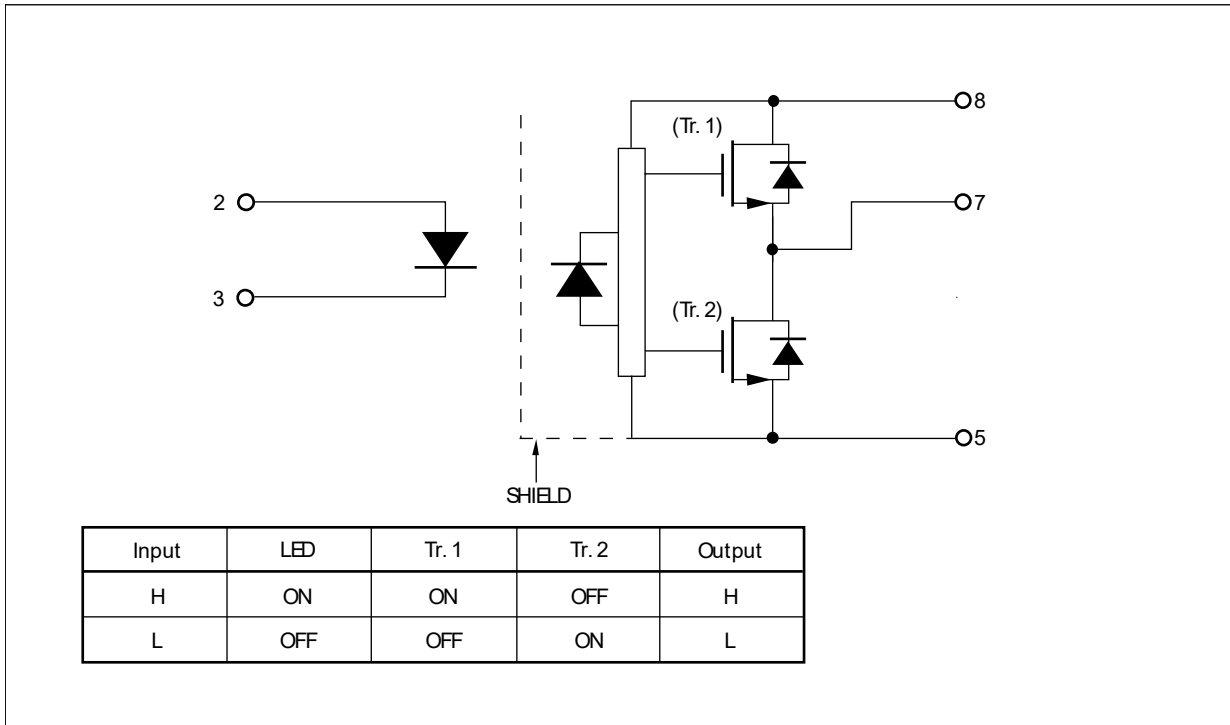

MARKING EXAMPLE

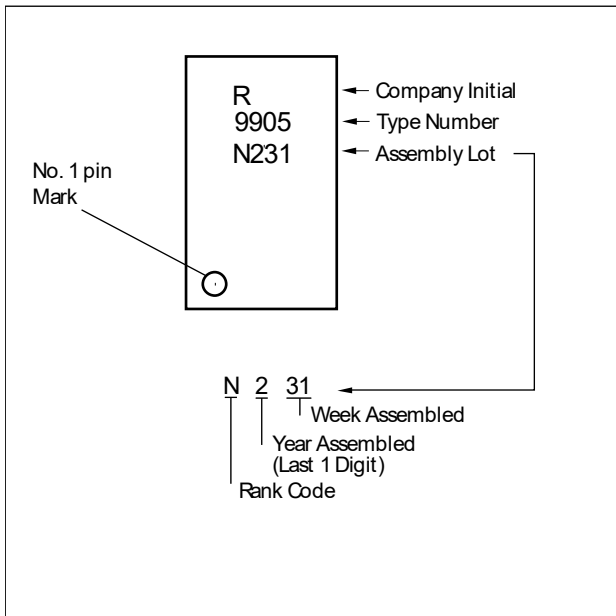

## ORDERING INFORMATION

Part Number	Order Number	Solder Plating Specification	Packing Style	Safety Standard Approval	Application Part Number <sup>*1</sup>
PS9905	PS9905-Y-AX	Pb-Free (Ni/Pd/Au)	10 pcs (Tape 10 pcs cut)	Standard products (UL, CSA, SEMKO approved)	PS9905
PS9905-F3	PS9905-Y-F3-AX		Embossed Tape 1 000 pcs/reel		
PS9905-V	PS9905-Y-V-AX		10 pcs (Tape 10 pcs cut)	UL, CSA, SEMIKO,	
PS9905-V-F3	PS9905-Y-V-F3-AX		Embossed Tape 1 000 pcs/reel	DIN EN60747-5-5 approved	

Note: \*1. For the application of the Safety Standard, following part number should be used.

ABSOLUTE MAXIMUM RATINGS ( $T_A = 25\text{ }^\circ\text{C}$ , unless otherwise specified)

Parameter		Symbol	Ratings	Unit
Diode	Forward Current	$I_F$	25	mA
	Peak Transient Forward Current (Pulse Width < 1 $\mu\text{s}$ )	$I_{F(\text{TRAN})}$	1.0	A
	Reverse Voltage	$V_R$	5	V
	Power Dissipation <sup>*1, *6</sup>	$P_D$	45	mW
Detector	High Level Peak Output Current <sup>*2</sup>	$I_{OH(\text{PEAK})}$	2.5	A
	Low Level Peak Output Current <sup>*2</sup>	$I_{OL(\text{PEAK})}$	2.5	A
	Supply Voltage	$(V_{CC} - V_{EE})$	0 to 35	V
	Output Voltage	$V_O$	0 to $V_{CC}$	V
	Power Dissipation <sup>*3, *6</sup>	$P_C$	250	mW
Isolation Voltage <sup>*4</sup>		$BV$	7 500	Vr.m.s.
Operating Frequency <sup>*5</sup>		$f$	50	kHz
Operating Ambient Temperature		$T_A$	-40 to +110	$^\circ\text{C}$
Storage Temperature		$T_{\text{stg}}$	-55 to +125	$^\circ\text{C}$

Notes: \*1. Derating to be set after 0.8 mW/ $^\circ\text{C}$  at  $T_A = 85\text{ }^\circ\text{C}$  or more.

\*2. Maximum pulse width = 10  $\mu\text{s}$ , Maximum duty cycle = 0.2 %

\*3. Reduced to 5.2 mW/ $^\circ\text{C}$  at  $T_A = 85\text{ }^\circ\text{C}$  or more

\*4. AC voltage for 1 minute at  $T_A = 25\text{ }^\circ\text{C}$ , RH = 60 % between input and output.

Pins 1-4 shorted together, 5-8 shorted together.

\*5.  $I_{OH(\text{PEAK})} \leq 2.0\text{ A}$  ( $\leq 0.3\text{ }\mu\text{s}$ ),  $I_{OL(\text{PEAK})} \leq 2.0\text{ A}$  ( $\leq 0.3\text{ }\mu\text{s}$ )

\*6. Mounted on glass epoxy substrate of 75 mm  $\times$  115 mm  $\times$  t1.5 mm

## RECOMMENDED OPERATING CONDITIONS

Parameter	Symbol	MIN.	TYP.	MAX.	Unit
Supply Voltage	$(V_{CC} - V_{EE})$	15		30	V
Forward Current (ON)	$I_{F(\text{ON})}$	10	12	14	mA
Forward Voltage (OFF)	$V_{F(\text{OFF})}$	-2		0.8	V
Operating Ambient Temperature	$T_A$	-40		110	$^\circ\text{C}$

## ELECTRICAL CHARACTERISTICS

(V<sub>EE</sub> = GND, unless otherwise specified and refer to RECOMMENDED OPERATING CONDITIONS)

	Parameter	Symbol	Conditions	MIN.	TYP.*1	MAX.	Unit
Diode	Forward Voltage	V <sub>F</sub>	I <sub>F</sub> = 10 mA, T <sub>A</sub> = 25 °C	1.3	1.56	1.8	V
	Reverse Current	I <sub>R</sub>	V <sub>R</sub> = 3 V, T <sub>A</sub> = 25 °C			10	μA
	Terminal Capacitance	C <sub>t</sub>	f = 1 MHz, V <sub>F</sub> = 0 V, T <sub>A</sub> = 25 °C		30		pF
Detector	High Level Output Current	I <sub>OH</sub>	V <sub>O</sub> = (V <sub>CC</sub> - 4 V) <sup>*2</sup>	0.5	2.0		A
			V <sub>O</sub> = (V <sub>CC</sub> - 15 V) <sup>*3</sup>	2.0			
	Low Level Output Current	I <sub>OL</sub>	V <sub>O</sub> = (V <sub>EE</sub> + 2.5 V) <sup>*2</sup>	0.5	2.0		A
			V <sub>O</sub> = (V <sub>EE</sub> + 15 V) <sup>*3</sup>	2.0			
	High Level Output Voltage	V <sub>OH</sub>	I <sub>O</sub> = -100 mA <sup>*4</sup>	V <sub>CC</sub> - 3.0	V <sub>CC</sub> - 1.5		V
	Low Level Output Voltage	V <sub>OL</sub>	I <sub>O</sub> = 100 mA		0.1	0.5	V
	High Level Supply Current	I <sub>CCH</sub>	V <sub>O</sub> = open, I <sub>F</sub> = 12 mA		1.4	3.0	mA
	Low Level Supply Current	I <sub>CCL</sub>	V <sub>O</sub> = open, V <sub>F</sub> = -2 to +0.8 V		1.3	3.0	mA
	UVLO Threshold	V <sub>UVLO+</sub> V <sub>UVLO-</sub>	V <sub>O</sub> > 5 V, I <sub>F</sub> = 12 mA	10.8	12.3	13.4	V
				9.5	11.0	12.5	
UVLO Hysteresis	UVLO <sub>HYS</sub>	V <sub>O</sub> > 5 V, I <sub>F</sub> = 12 mA	0.4	1.3		V	
Coupled	Threshold Input Current (L → H)	I <sub>FLH</sub>	I <sub>O</sub> = 0 mA, V <sub>O</sub> > 5 V		2.9	6.0	mA
	Threshold Input Voltage (H → L)	V <sub>FHL</sub>	I <sub>O</sub> = 0 mA, V <sub>O</sub> < 5 V	0.8			V

Notes: \*1. Typical values at T<sub>A</sub> = 25 °C

\*2. Maximum pulse width = 50 μs, Maximum duty cycle = 0.5 %.

\*3. Maximum pulse width = 10 μs, Maximum duty cycle = 0.2 %.

\*4. V<sub>OH</sub> is measured with the DC load current in this testing (Maximum pulse width = 2 ms, Maximum duty cycle = 20 %).

## SWITCHING CHARACTERISTICS

( $V_{EE} = \text{GND}$ , unless otherwise specified and refer to RECOMMENDED OPERATING CONDITIONS)

Parameter	Symbol	Conditions	MIN.	TYP.*1	MAX.	Unit	
Propagation Delay Time (L → H)	$t_{PLH}$	$R_g = 10 \Omega$ , $C_g = 10 \text{ nF}^2$ , $f = 10 \text{ kHz}$ , Duty Cycle = 50 %, $I_F = 12 \text{ mA}$		0.09	0.15	$\mu\text{s}$	
Propagation Delay Time (H → L)	$t_{PHL}$			0.1	0.15	$\mu\text{s}$	
Pulse Width Distortion (PWD)	$ t_{PHL} - t_{PLH} $				0.01	0.075	$\mu\text{s}$
Propagation Delay Time (Difference Between Any Two Products)	$t_{PHL} - t_{PLH}$			-0.1		0.1	$\mu\text{s}$
Rise Time	$t_r$				50		ns
Fall Time	$t_f$				50		ns
UVLO (Turn On Delay)	$t_{UVLO \text{ ON}}$	$V_O > 5 \text{ V}$ , $I_F = 12 \text{ mA}$		0.8		$\mu\text{s}$	
UVLO (Turn Off Delay)	$t_{UVLO \text{ OFF}}$	$V_O < 5 \text{ V}$ , $I_F = 12 \text{ mA}$		0.6		$\mu\text{s}$	
Common Mode Transient Immunity at High Level Output	$ CM_H $	$T_A = 25 \text{ }^\circ\text{C}$ , $I_F = 12 \text{ mA}$ , $V_{CC} = 30 \text{ V}$ , $V_{O(MIN.)} = 26 \text{ V}$ , $V_{CM} = 1.5 \text{ kV}$	25			$\text{kV}/\mu\text{s}$	
Common Mode Transient Immunity at Low Level Output	$ CM_L $	$T_A = 25 \text{ }^\circ\text{C}$ , $I_F = 0 \text{ mA}$ , $V_{CC} = 30 \text{ V}$ , $V_{O(MAX.)} = 1 \text{ V}$ , $V_{CM} = 1.5 \text{ kV}$	25			$\text{kV}/\mu\text{s}$	

Notes: \*1. Typical values at  $T_A = 25 \text{ }^\circ\text{C}$

\*2. This load condition is equivalent to the IGBT load at 1 200 V / 75 A.

TEST CIRCUIT

Fig. 1  $I_{OH}$  Test Circuit

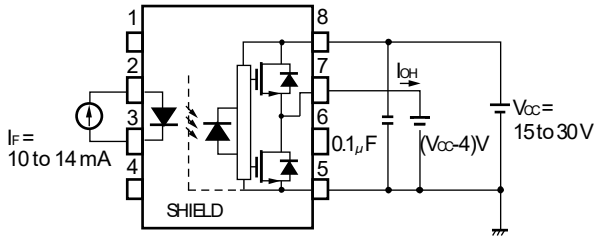

Fig. 2  $I_{OL}$  Test Circuit

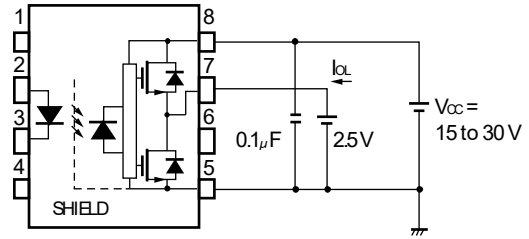

Fig. 3  $V_{OH}$  Test Circuit

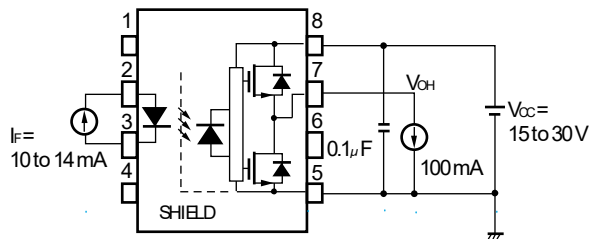

Fig. 4  $V_{OL}$  Test Circuit

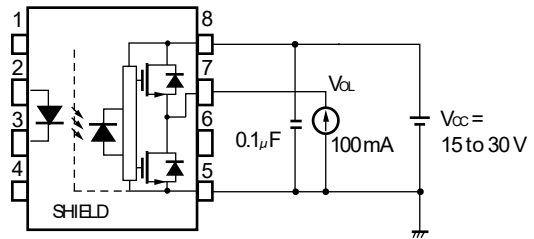

Fig. 5  $I_{FLH}$  Test Circuit

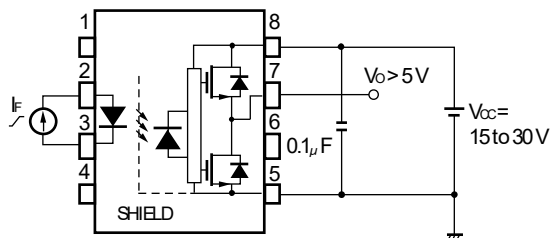

Fig. 6  $UVLO$  Test Circuit

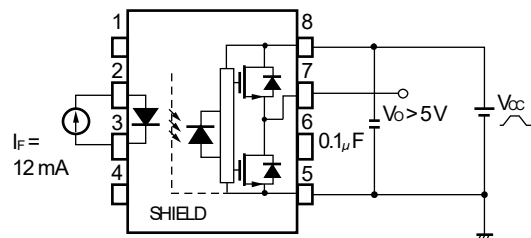

Fig. 7  $t_{PLH}$ ,  $t_{PHL}$ ,  $t_r$ ,  $t_f$  Test Circuit and Wave Forms

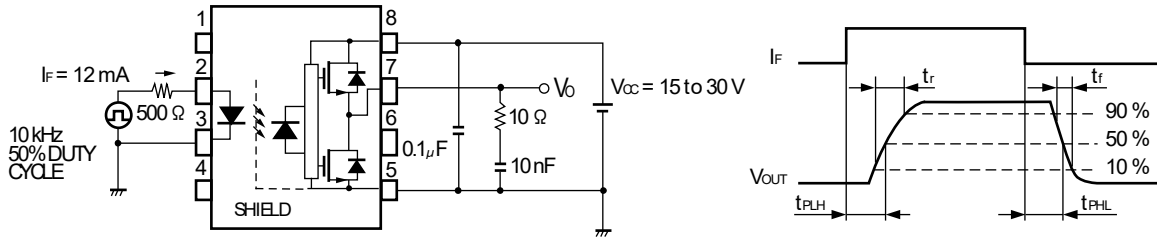
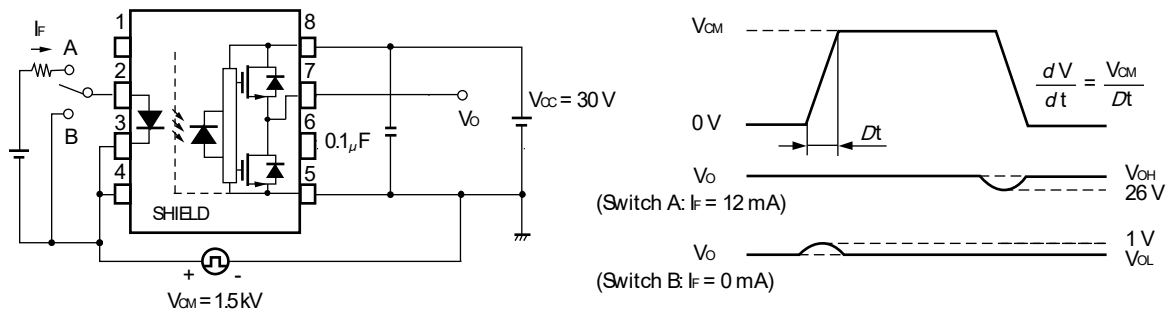

Fig. 8 CMR Test Circuit and Wave Forms





TYPICAL CHARACTERISTICS (T<sub>A</sub> = 25 °C, unless otherwise specified)

DIODE POWER DISSIPATION vs. AMBIENT TEMPERATURE

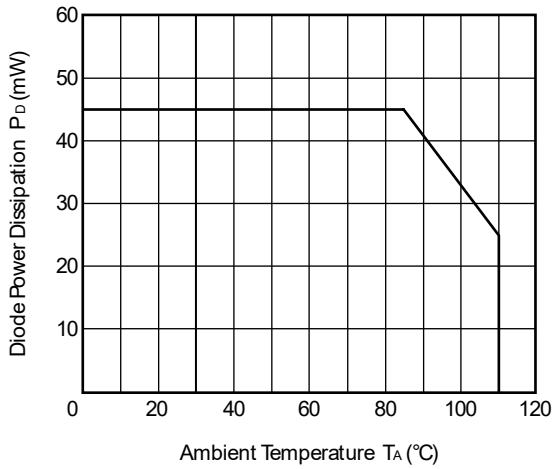

DETECTOR POWER DISSIPATION vs. AMBIENT TEMPERATURE

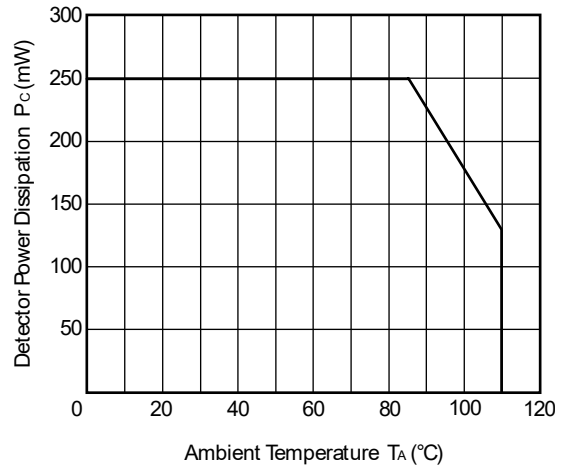

FORWARD CURRENT vs. FORWARD VOLTAGE

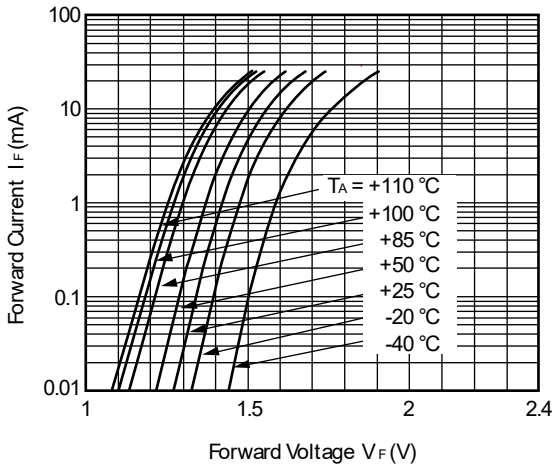

THRESHOLD INPUT CURRENT vs. AMBIENT TEMPERATURE

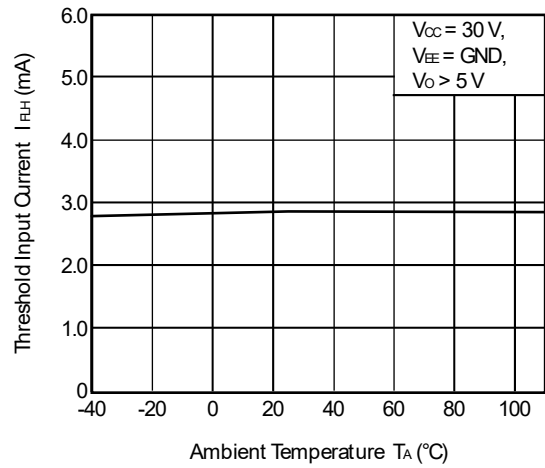

OUTPUT VOLTAGE vs. FORWARD CURRENT

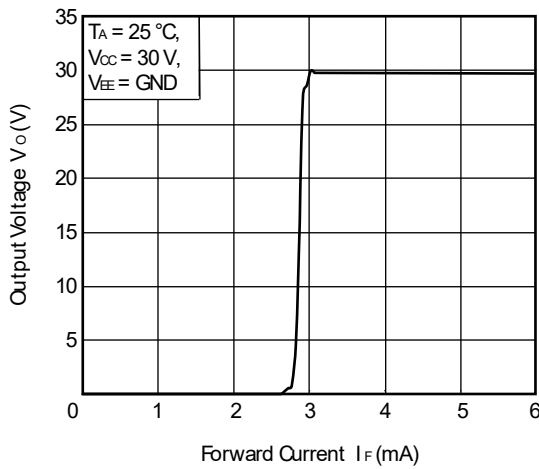

HIGH LEVEL OUTPUT VOLTAGE - SUPPLY VOLTAGE vs. HIGH LEVEL OUTPUT CURRENT

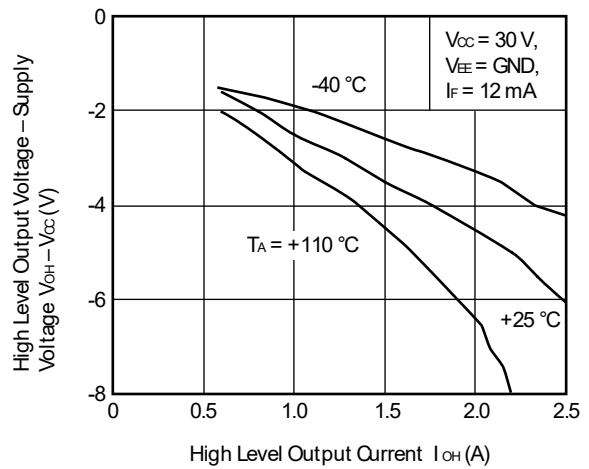

**Remark** The graphs indicate nominal characteristics.

LOW LEVEL OUTPUT VOLTAGE vs. LOW LEVEL OUTPUT CURRENT

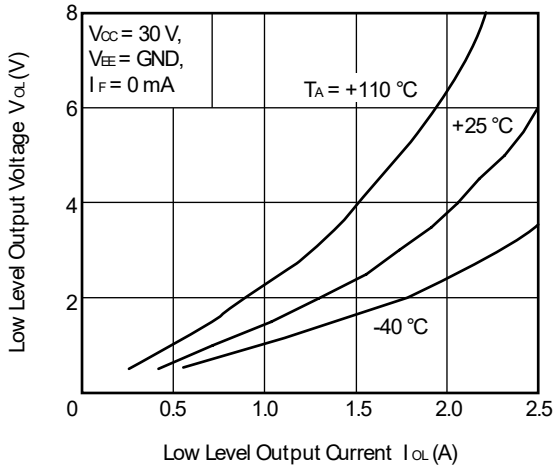

PROPAGATION DELAY TIME, PULSE WIDTH DISTORTION vs. FORWARD CURRENT

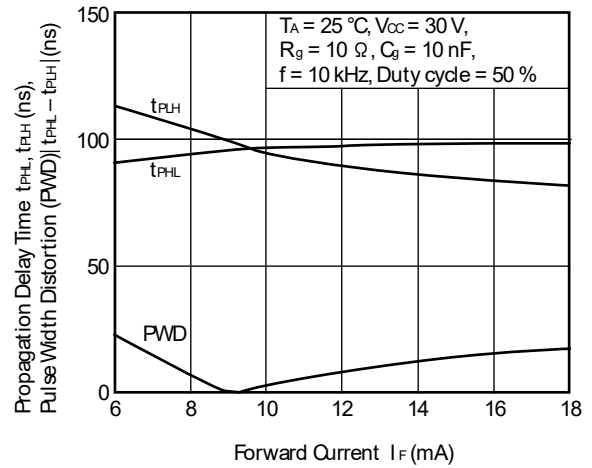

PROPAGATION DELAY TIME, PULSE WIDTH DISTORTION vs. SUPPLY VOLTAGE

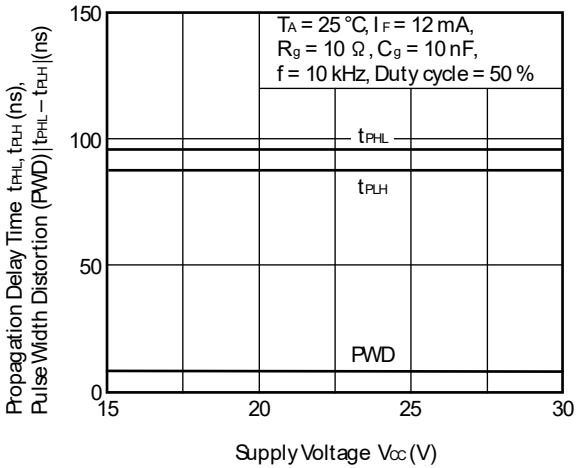

PROPAGATION DELAY TIME, PULSE WIDTH DISTORTION vs. LOAD CAPACITANCE

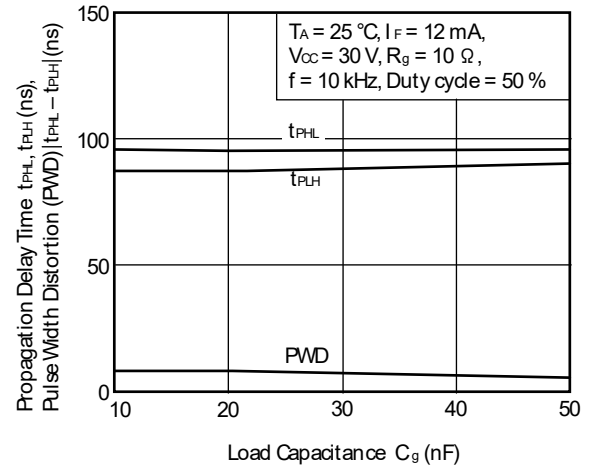

PROPAGATION DELAY TIME, PULSE WIDTH DISTORTION vs. LOAD RESISTANCE

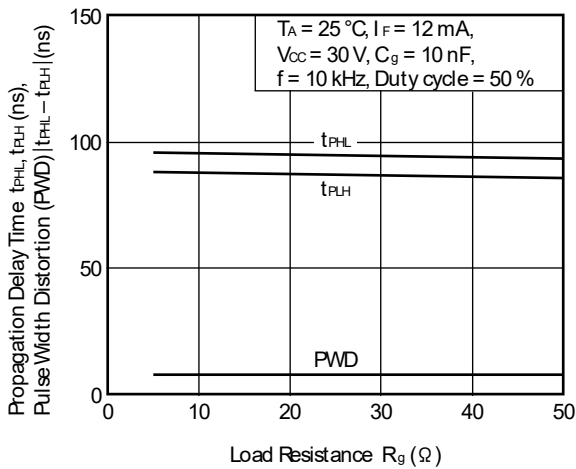

PROPAGATION DELAY TIME, PULSE WIDTH DISTORTION vs. AMBIENT TEMPERATURE

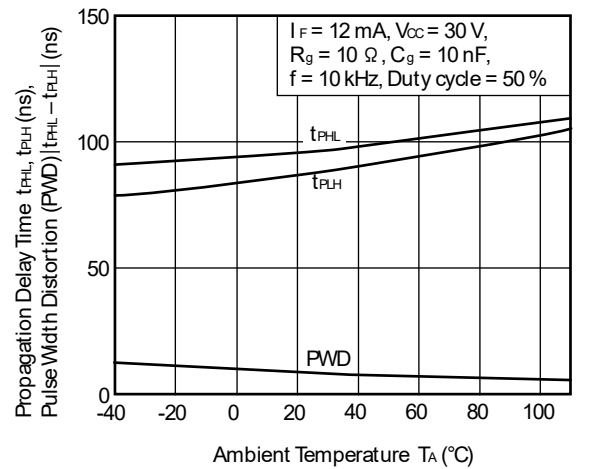

**Remark** The graphs indicate nominal characteristics.

SUPPLY CURRENT vs. AMBIENT TEMPERATURE

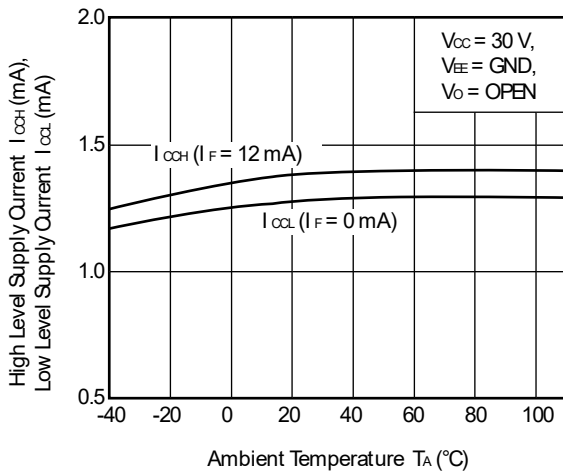

SUPPLY CURRENT vs. SUPPLY VOLTAGE

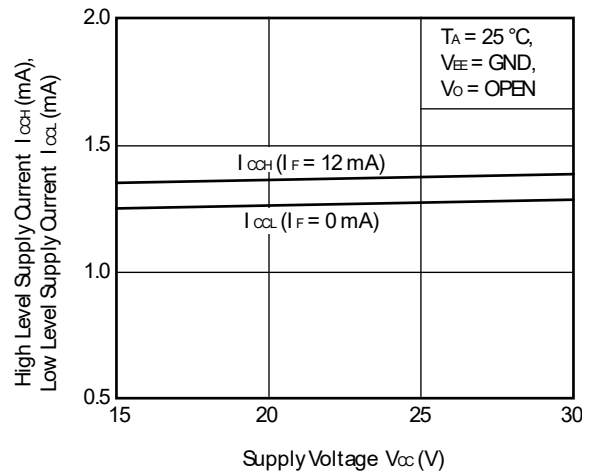

HIGH LEVEL OUTPUT VOLTAGE – SUPPLY VOLTAGE vs. AMBIENT TEMPERATURE

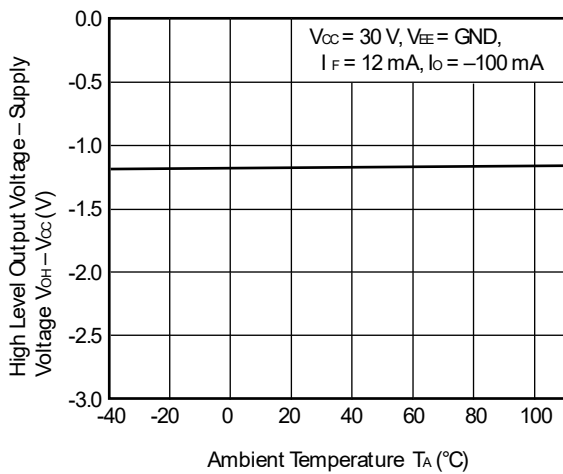

LOW LEVEL OUTPUT VOLTAGE vs. AMBIENT TEMPERATURE

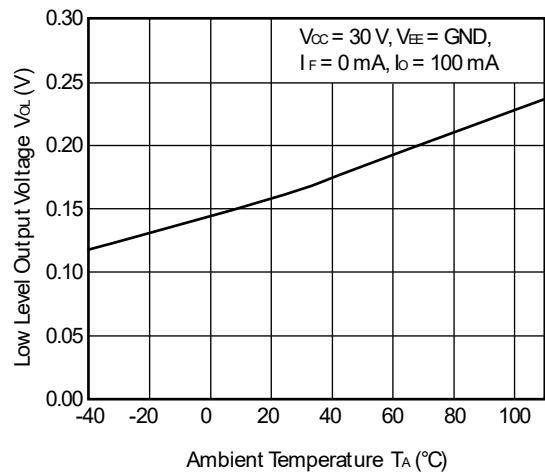

HIGH LEVEL OUTPUT CURRENT vs. AMBIENT TEMPERATURE

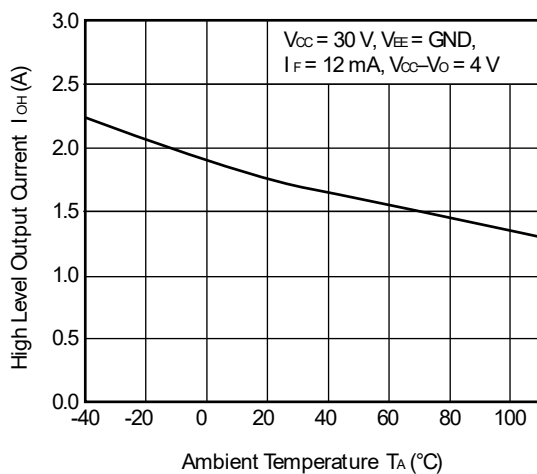

LOW LEVEL OUTPUT CURRENT vs. AMBIENT TEMPERATURE

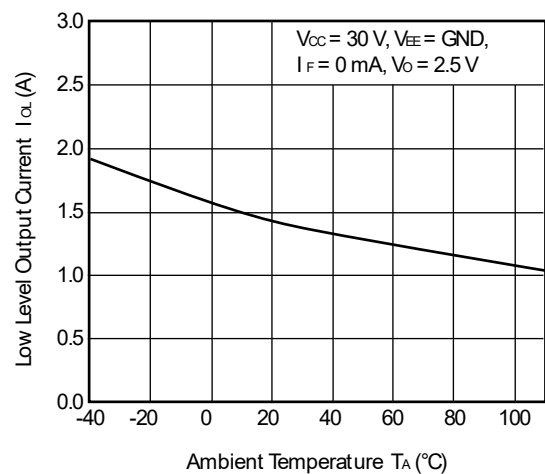

**Remark** The graphs indicate nominal characteristics.

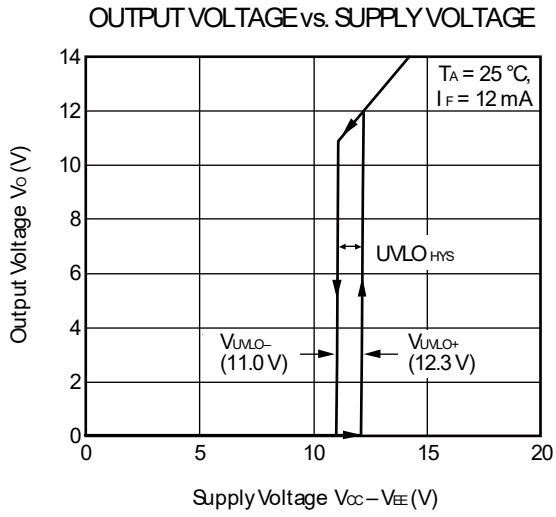

**Remark** The graphs indicate nominal characteristics.

TAPING SPECIFICATIONS (UNIT: mm)

Outline and Dimensions (Tape)

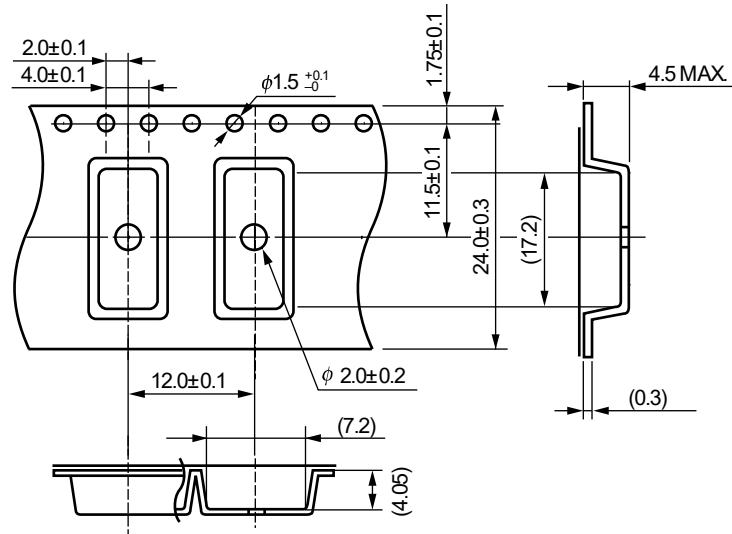

Tape Direction

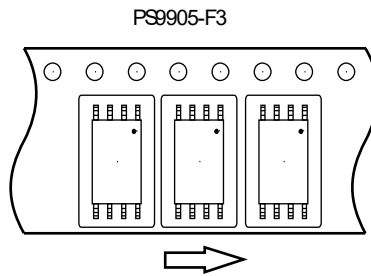

Outline and Dimensions (Reel)

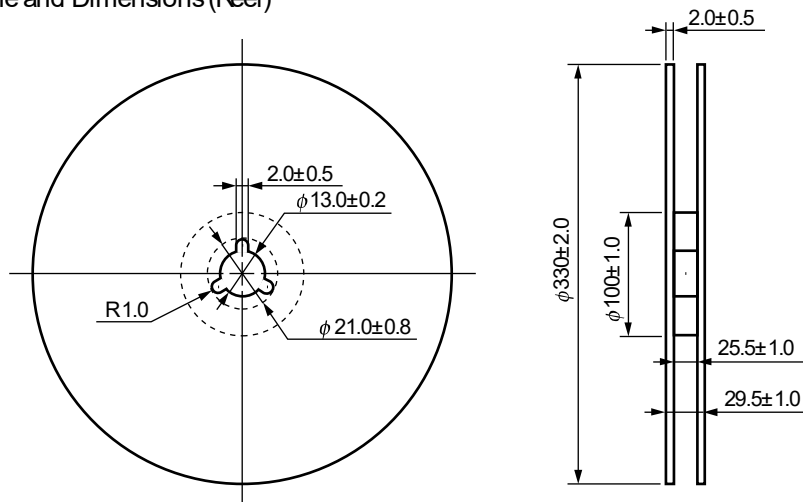

Packing: 1 000 pcs/reel

RECOMMENDED MOUNT PAD DIMENSIONS (UNIT: mm)

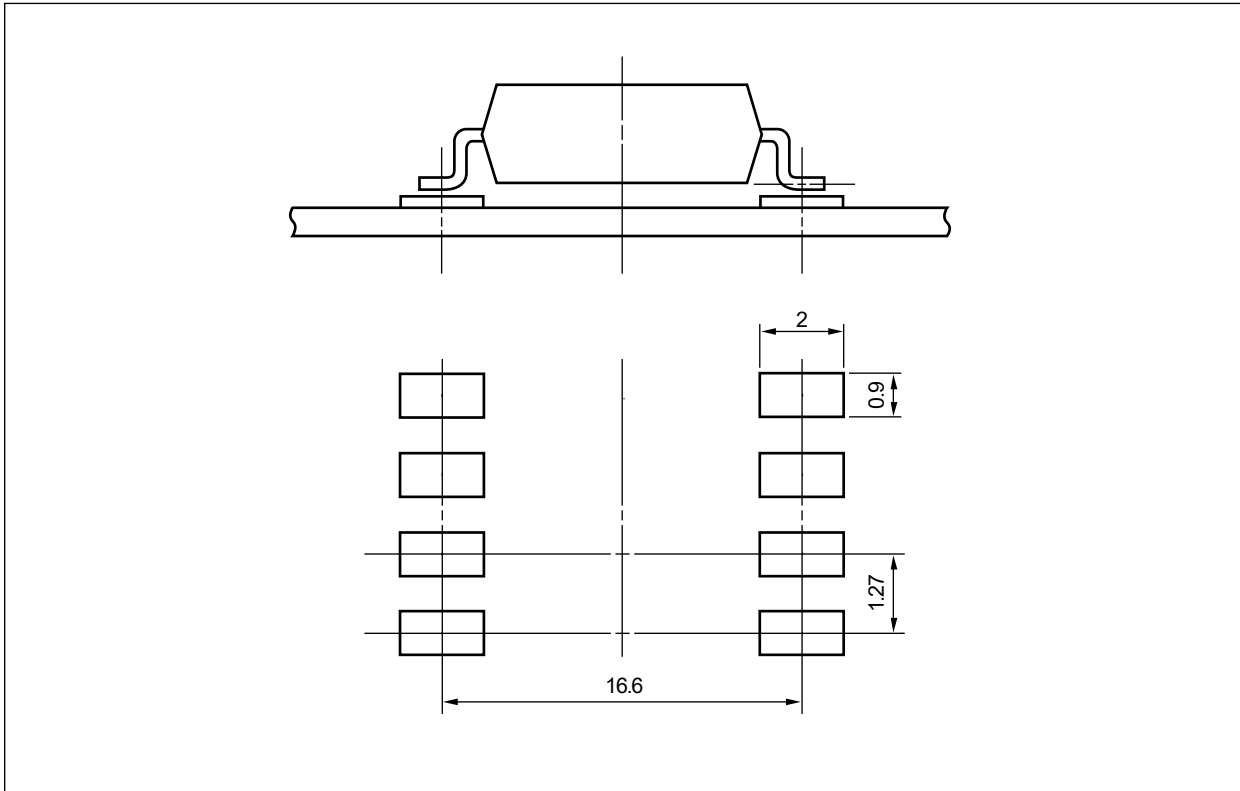

【8pin LSDIP】

Remark All dimensions in this figure must be evaluated before use.

## NOTES ON HANDLING

## 1. Recommended soldering conditions

## (1) Infrared reflow soldering

- Peak reflow temperature 260 °C or below (package surface temperature)
- Time of peak reflow temperature 10 seconds or less
- Time of temperature higher than 220 °C 60 seconds or less
- Time to preheat temperature from 120 to 180 °C 120 ± 30 s
- Number of reflows Three
- Flux Rosin flux containing small amount of chlorine (The flux with a maximum chlorine content of 0.2 Wt% is recommended.)

Recommended Temperature Profile of Infrared Reflow

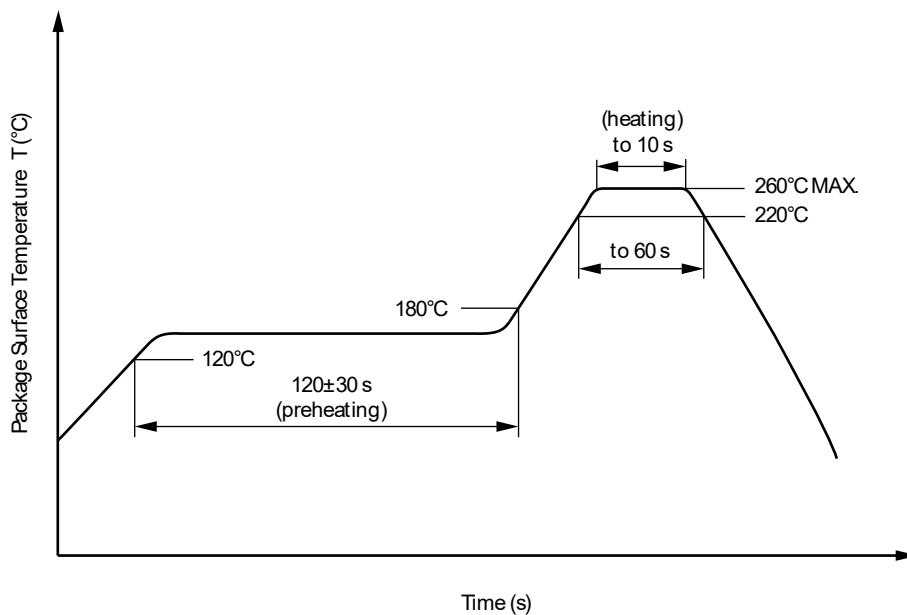

## (2) Wave soldering

- Temperature 260 °C or below (molten solder temperature)
- Time 10 seconds or less
- Preheating conditions 120 °C or below (package surface temperature)
- Number of times One (Allowed to be dipped in solder including plastic mold portion.)
- Flux Rosin flux containing small amount of chlorine (The flux with a maximum chlorine content of 0.2 Wt% is recommended.)

## (3) Soldering by Soldering Iron

- Peak Temperature (lead part temperature) 350 °C or below
- Time (each pins) 3 seconds or less
- Flux Rosin flux containing small amount of chlorine  
(The flux with a maximum chlorine content of 0.2 Wt% is recommended.)

(a) Soldering of leads should be made at the point 1.5 to 2.0 mm from the root of the lead

(b) Please be sure that the temperature of the package would not be heated over 110 °C

## (4) Cautions

- Flux Cleaning  
Avoid cleaning with Freon based or halogen-based (chlorinated etc.) solvents.
- Do not use fixing agents or coatings containing halogen-based substances.

2. Cautions regarding noise

Be aware that when voltage is applied suddenly between the photocoupler's input and output at startup, the output transistor may enter the on state, even if the voltage is within the absolute maximum ratings.

## USAGE CAUTIONS

1. This product is weak for static electricity by designed with high-speed integrated circuit so protect against static electricity when handling.
2. Board designing
  - (1) By-pass capacitor of more than 0.1  $\mu\text{F}$  is used between  $V_{\text{CC}}$  and GND near device. Also, ensure that the distance between the leads of the photocoupler and capacitor is no more than 10 mm.
  - (2) When designing the printed wiring board, ensure that the pattern of the IGBT collectors/emitters is not too close to the input block pattern of the photocoupler.

If the pattern is too close to the input block and coupling occurs, a sudden fluctuation in the voltage on the IGBT output side might affect the photocoupler's LED input, leading to malfunction or degradation of characteristics. (If the pattern needs to be close to the input block, to prevent the LED from lighting during the off state due to the abovementioned coupling, design the input-side circuit so that the bias of the LED is reversed, within the range of the recommended operating conditions, and be sure to thoroughly evaluate operation.)
  - (3) Pin 1, 4 (which is an NC\*1 pin) can either be connected directly to the GND pin on the LED side or left open. Also, Pin 6 (which is an NC\*1 pin) can either be connected directly to the GND pin on the detector side or left open.

Unconnected pins should not be used as a bypass for signals or for any other similar purpose because this may degrade the internal noise environment of the device.

Note: \*1. NC: Non-Connection (No Connection)
3. Make sure the rise/fall time of the forward current is 0.5  $\mu\text{s}$  or less.
4. In order to avoid malfunctions, make sure the rise/fall slope of the supply voltage is 3 V/ $\mu\text{s}$  or less.
5. Avoid storage at a high temperature and high humidity.



SPECIFICATION OF VDE MARKS LICENSE DOCUMENT

Parameter	Symbol	Rating	Unit
Climatic test class (IEC 60068-1/DIN EN 60068-1)		40/110/21	
Dielectric strength			
maximum operating isolation voltage	$U_{IORM}$	1 600	$V_{peak}$
Test voltage (partial discharge test, procedure a for type test and random test) $U_{pr} = 1.6 \times U_{IORM.}, P_d < 5 \text{ pC}$	$U_{pr}$	2 560	$V_{peak}$
Test voltage (partial discharge test, procedure b for all devices) $U_{pr} = 1.875 \times U_{IORM.}, P_d < 5 \text{ pC}$	$U_{pr}$	3 000	$V_{peak}$
Highest permissible overvoltage	$U_{IOTM}$	12 000	$V_{peak}$
Degree of pollution (IEC 60664-1/DIN EN 60664-1 (VDE 0110-1))		2	
Comparative tracking index (IEC 60112/DIN EN 60112 (VDE 0303 Part 11))	CTI	175	
Material group (IEC 60664-1/DIN EN 60664-1 (VDE 0110-1))		III a	
Storage temperature range	$T_{stg}$	-55 to +125	°C
Operating temperature range	$T_A$	-40 to +110	°C
Isolation resistance, minimum value $V_{IO} = 500 \text{ V dc at } T_A = 25 \text{ °C}$ $V_{IO} = 500 \text{ V dc at } T_A \text{ MAX. at least } 100 \text{ °C}$	Ris MIN. Ris MIN.	$10^{12}$ $10^{11}$	$\Omega$ $\Omega$
Safety maximum ratings (maximum permissible in case of fault, see thermal derating curve)			
Package temperature	$T_{si}$	175	°C
Current (input current $I_F$ , $P_{si} = 0$ )	$I_{si}$	400	mA
Power (output or total power dissipation)	$P_{si}$	700	mW
Isolation resistance $V_{IO} = 500 \text{ V dc at } T_A = T_{si}$	Ris MIN.	$10^9$	$\Omega$

Dependence of maximum safety ratings with package temperature

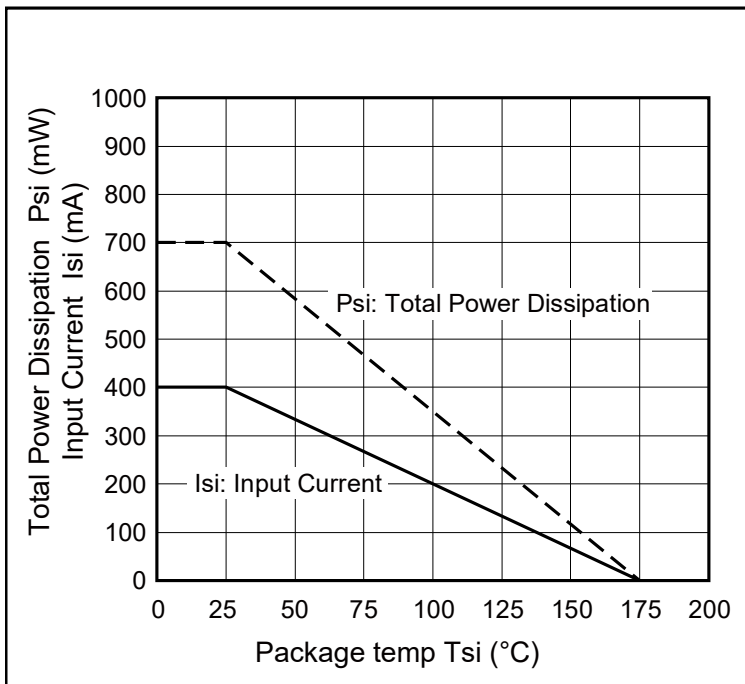

Method a Destructive Test, Type and Sample Test

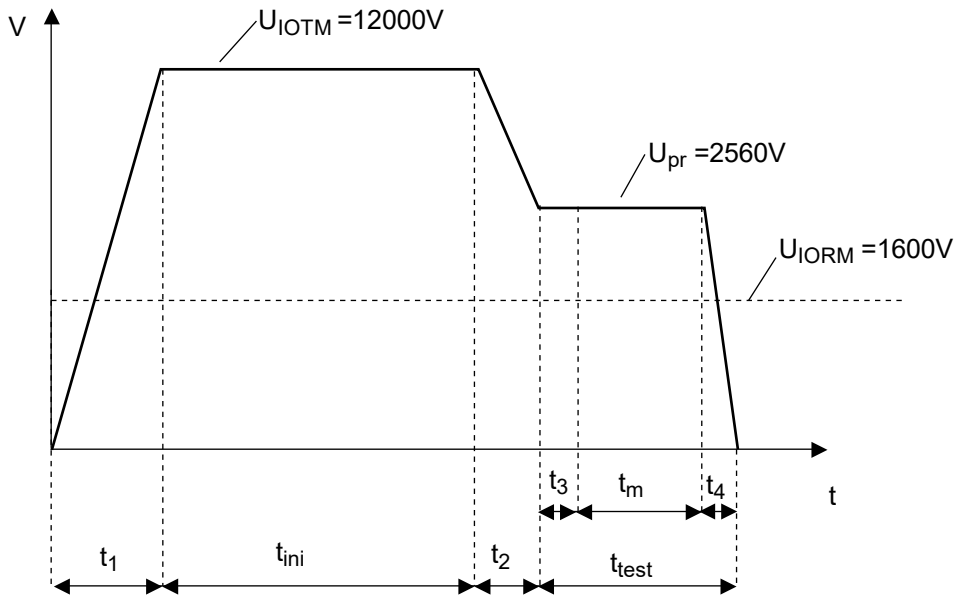

$t_1, t_2 = 1 \text{ to } 10 \text{ sec}$   
 $t_3, t_4 = 1 \text{ sec}$   
 $t_m(\text{PARTIAL DISCHARGE}) = 10 \text{ sec}$   
 $t_{test} = 12 \text{ sec}$   
 $t_{ini} = 60 \text{ sec}$

Method b Non-destructive Test, 100% Production Test

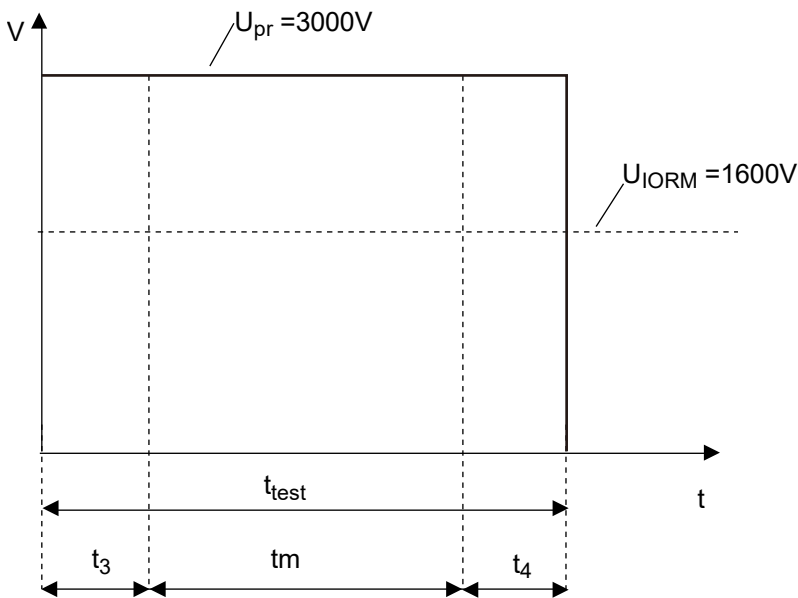

$t_3, t_4 = 0.1 \text{ sec}$   
 $t_m(\text{PARTIAL DISCHARGE}) = 1.0 \text{ sec}$   
 $t_{test} = 1.2 \text{ sec}$

<p><b>Caution</b> GaAs Products</p>	<p>This product uses gallium arsenide (GaAs). GaAs vapor and powder are hazardous to human health if inhaled or ingested, so please observe the following points.</p> <ul style="list-style-type: none"><li>• Follow related laws and ordinances when disposing of the product. If there are no applicable laws and/or ordinances, dispose of the product as recommended below.</li></ul> <ol style="list-style-type: none"><li>1. Commission a disposal company able to (with a license to) collect, transport and dispose of materials that contain arsenic and other such industrial waste materials.</li><li>2. Exclude the product from general industrial waste and household garbage, and ensure that the product is controlled (as industrial waste subject to special control) up until final disposal.</li></ol> <ul style="list-style-type: none"><li>• Do not burn, destroy, cut, crush, or chemically dissolve the product.</li><li>• Do not lick the product or in any way allow it to enter the mouth.</li></ul>
-------------------------------------	---