

PS-15 / PSC-15

15-mm carbon / cermet SMD potentiometer

The PS-15 and PSC-15 potentiometers offer control where frequent adjustment is required. The shaftless design allows for employment of different engagement mechanisms, such as a customized shaft, a motor control or a human interface adjustment. This potentiometer can also control variable outputs including frequency, change in motor speed or volume.



KEY FEATURES

- ▶ Excellent performance (up to 3% linearity)
- ▶ Carbon or cermet resistive element
- ▶ Polyester / Alumina substrate
- ▶ Up to 38 mechanical detents for tactile feedback
- ▶ Up to 100.000 life cycles
- ▶ IP54 protection
- ▶ Embossed tape packaging according to IEC 60286-3:2007
- ▶ Wiper positioned at initial, 50% or fully clockwise
- ▶ Linear, logarithmic and antilogarithmic tapers (PSC-15)
- ▶ Self extinguishable plastic (UL 94V-0) available
- ▶ Locating pins for accurate PCB positioning
- ▶ Low torque version available

On request

- ▶ Shaft and knobs
- ▶ Long life models for control potentiometer applications

ELECTRICAL SPECIFICATIONS

	PS-15	PSC-15
Taper ¹	Lin	Lin, Log, Alog
Range of values ¹		
Lin	1KΩ ≤ Rn ≤ 1MΩ	100Ω ≤ Rn ≤ 5MΩ
Log, Alog	n/a	1KΩ ≤ Rn ≤ 5MΩ
Tolerance ¹		
100Ω ≤ Rn ≤ 1MΩ	± 30%	± 20%
1MΩ < Rn ≤ 5MΩ	n/a	± 30%
Max. Voltage		
Lin	250 Vdc	250 Vdc
Log, Alog	n/a	125 Vdc
Nominal power		
Lin	50°C (122°F) 0.25 W	70°C (158°F) 0.50 W
Log, Alog	n/a	0.25 W
Residual resistance ¹	≤ 0.5% Rn (5Ω min.)	
Equivalent noise resistance	≤ 3% Rn (3Ω min.)	
Operating temperature ¹	-40°C to +85°C (-40°F to +185°F)	-40°C to +90°C (-40°F to +194°F)

¹ Others available on request

APPLICATIONS

- ▶ Appliance program selection
- ▶ Thermostat adjustment
- ▶ Timer and control relays
- ▶ Consumer electronics
- ▶ Power tool controls
- ▶ Test and measurement equipment

PS-15 / PSC-15

15-mm carbon / cermet SMD potentiometer

MECHANICAL SPECIFICATIONS

	PS-15	PSC-15
Mechanical rotation angle ¹	265° ± 5°	
Electrical rotation angle ²	240° ± 20°	
Torque Rotational Stop	0.5 to 2.5 Ncm (0.7 to 3.4 in-oz) > 10 Ncm (>14 in-oz)	
Life ²	Up to 100k cycles	Up to 10k cycles

¹ Endless rotation available: STS-15 ² Others check availability

ENVIRONMENTAL TESTING

	Test method (CEI 393-1)	PS-15 ΔR(%)- typical test results	PSC-15 ΔR(%)- typical test results
Electrical life	1.000h at 50°C; 0.15W 1.000h at 70°C; 0.33W	±10% n/a	n/a ±5%
Mechanical life	1000 cycles at 10 to 15 cpm	±10% (Rn < 1M)	±3% (Rn < 1 M)
Temperature coefficient	-40°C; +90°C -40°C; +85°C -25°C; +70°C	n/a ±1500 ppm/°C ±1000 ppm/°C	±100 ppm/°C (Rn < 100K) n/a n/a
Thermal cycling	16h at 90°C and 2h at -40°C	±5%	±2.5%
Damp heat	500h at 40°C and 95% relative humidity (RH)	±15%	±5%
Vibration	2h each plane at 10Hz - 55Hz	±3%	±2%
Storage	6 month at 23°C ±2°C and 50% RH	±5%	±5%

Out of range values may not comply with these results. Standard test conditions: temperature: 23°C ±2°C and 45% to 70% RH

RECOMMENDED CONNECTIONS

Recommended connection circuit for a position sensor or control application (voltage divider circuit electronic design).

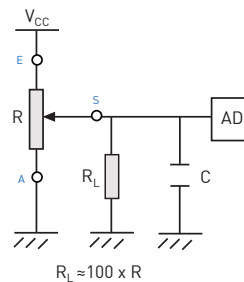

RECOMMENDED REFLOW PROFILE

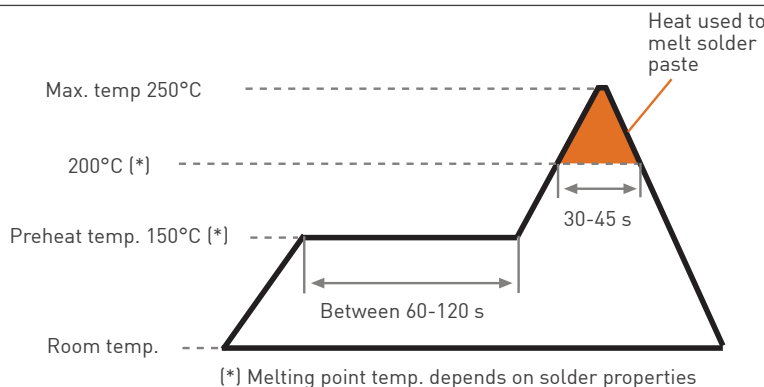

The recommended reflow profile is provided as a guideline. Optimal profile may differ due to oven type, assembly layout or other design or process variables. Customers should verify actual device performance in their specific application and reflow process. Please contact Piher if you require additional support.

PS-15 / PSC-15

15-mm carbon / cermet SMD potentiometer

HOW TO ORDER

Carbon potentiometer (Example: PS15TV50-102A3030)

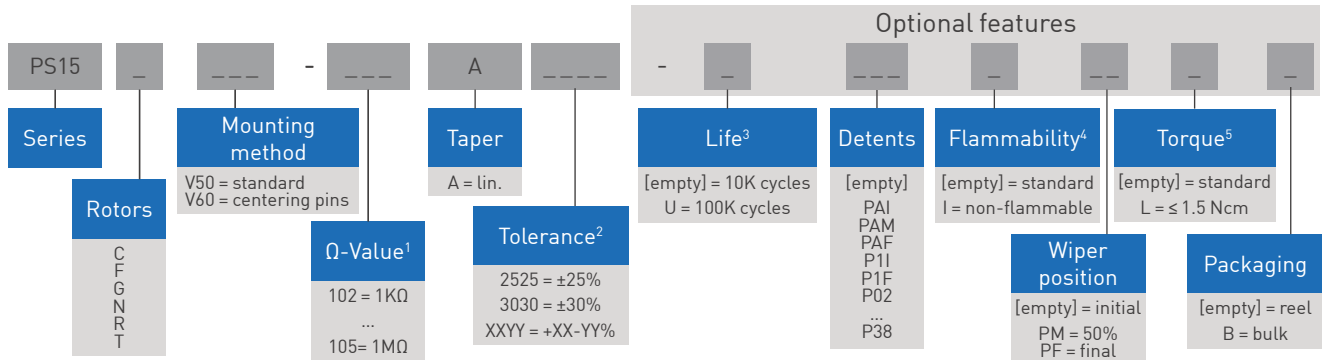

Cermet potentiometer (Example: PSC15TV50-103A3030)

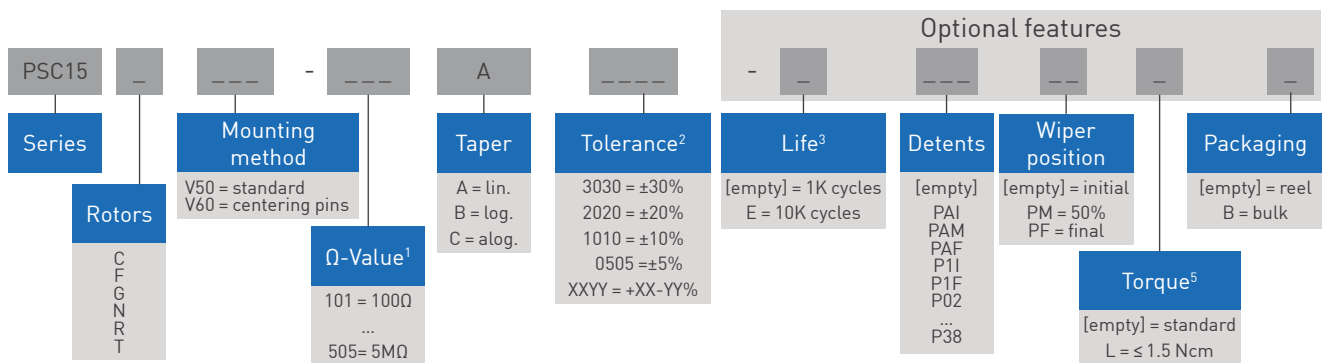

1. Ω- Value: XXX - First two digits of Ω-value; XXX - Number of zeros
2. Tolerance: For custom tolerance, please check availability: info@piher.net
3. Life: Higher available. To be studied on request.
4. Non-flammable according to UL 94V-0: housing and rotor. PSC-15 made of non-flammable material by standard.
5. Torque: No detent option available for low torque models.

STANDARD CONFIGURATION

	PS-15	PSC-15
Life	10.000 cycles	1.000 cycles
Non-flammable plastic	no	yes
Detents	none	
Packaging	reel	
Wiper Position	initial	
Housing color	dark grey	brown
Rotor color	dark grey	brown
Torque	0.4 to 2 Ncm	
Linearity	Controlled linearity up to 3% upon request	
Shafts/thumb wheels	Available separately, see PT-15 datasheet for possible options	

PS-15 / PSC-15

15-mm carbon / cermet SMD potentiometer

ROTORS

Removable shaft or thumbwheel / Wiper shown at initial position

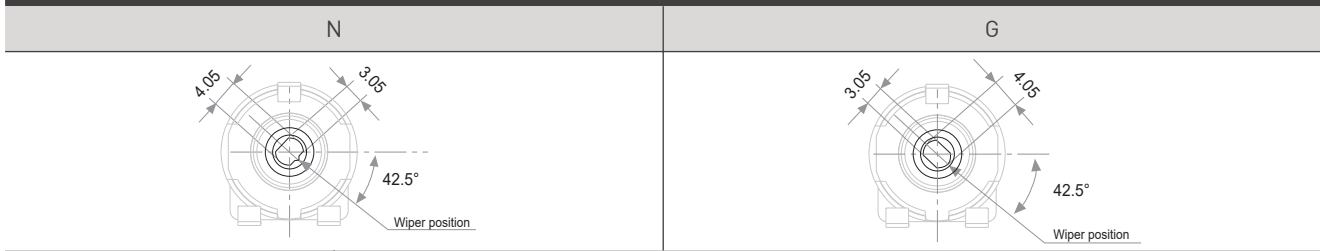

Wiper shown positioned at 50%

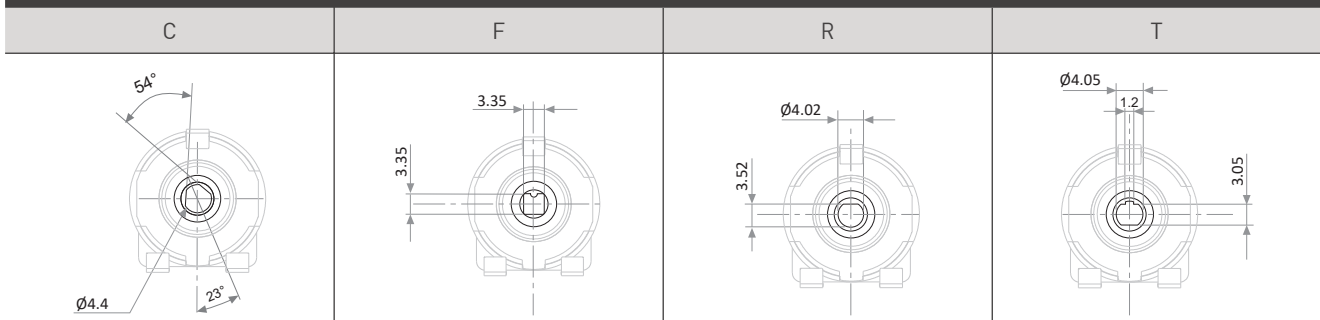

Default delivery is at initial position.

MOUNTING METHOD

V50 - without centering pins

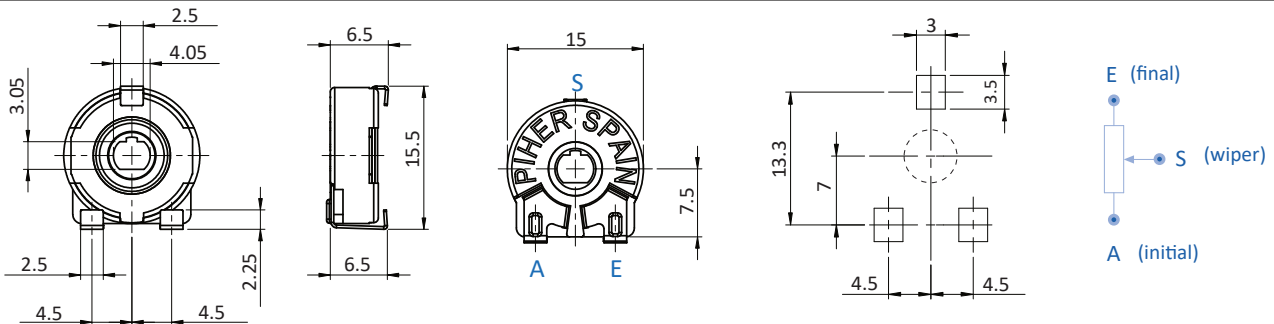

V60 - with centering pins

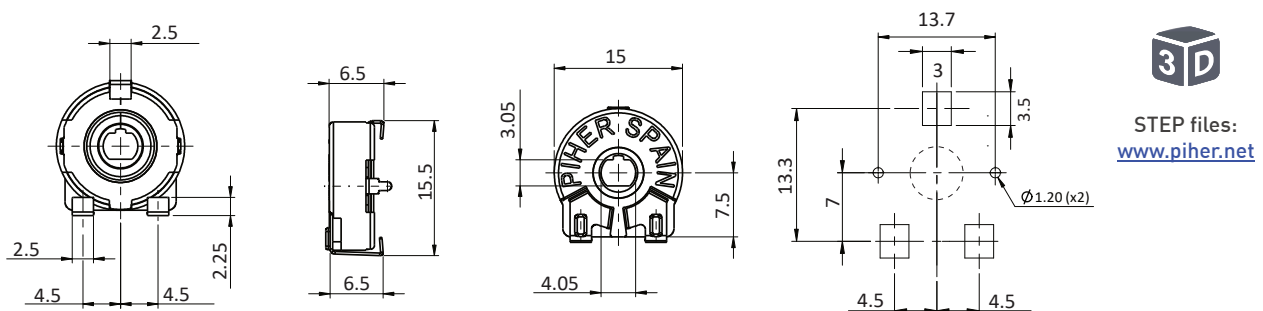

STANDARD RESISTANCE-VALUES AND TOLERANCES

Resistance Ω	100	200	220	250	470	500	1K	2K	2.2K	2.5K	4.7K	5K	10K	20K	22K	25K	47K	50K	100K	200K	220K	250K	470K	500K	1M	2M	2.5M	4.7M	5M
Order Code	101	201	221	251	471	501	102	202	222	252	472	502	103	203	223	253	473	503	104	204	224	254	474	504	105	205	255	475	505
Tolerance [PS-15]	n/a						30%															n/a							
Tolerance [PSC-15]	20%															30%													

PS-15 / PSC-15

15-mm carbon / cermet SMD potentiometer

TAPERS

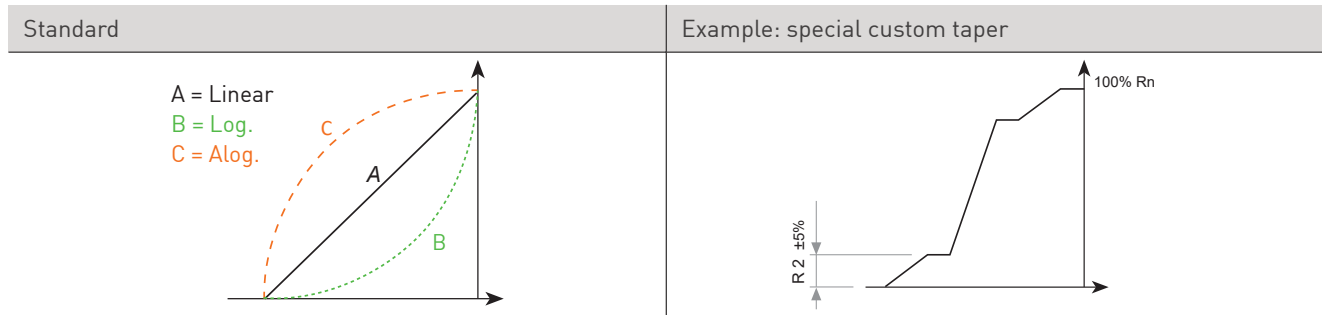

For more information on custom tapers contact Piher Sensing Systems.

DETENTS

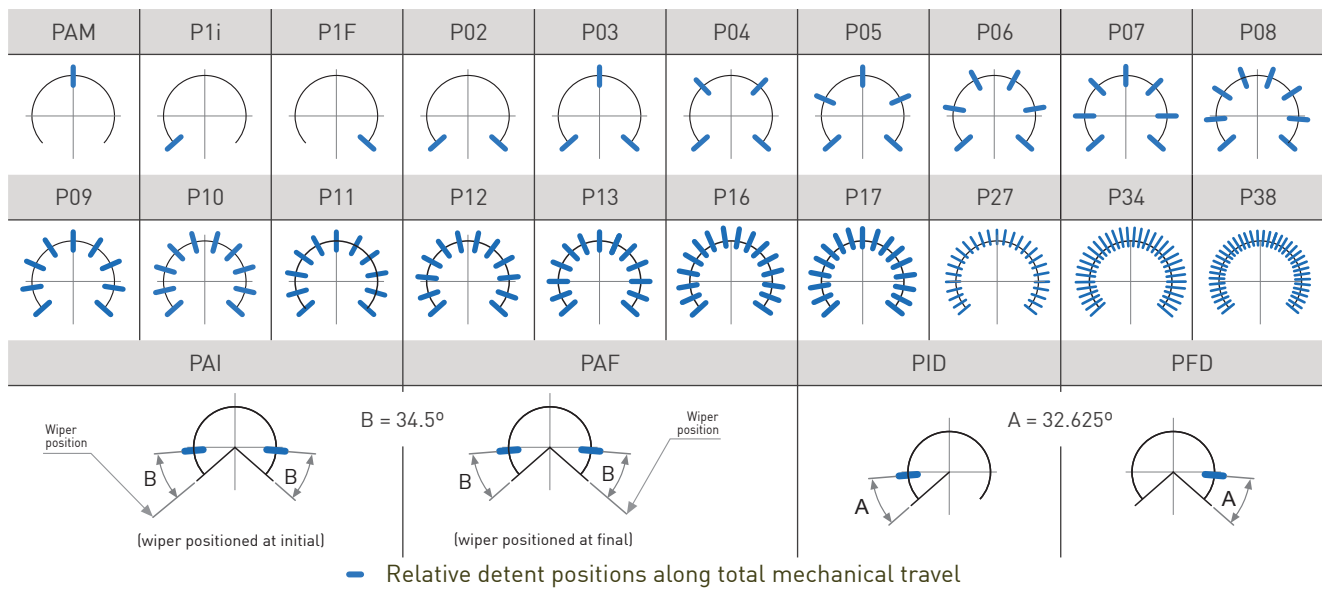

- Standard mechanical life is 500 cycles.
- Long life versions are available upon request and have the following characteristics at T^a: Potentiometers with 1 to 3 detents up to 10K cycles; Potentiometers with 4 and more detents up to 5K cycles
- Please consult Piher Sensing Systems if unique non-overlapping values at each detent position or LOG/ALOG tapers are required.
- Different output voltage values can be matched at each detent position [see next section].
- Detent torque can vary from 1.2 to 2.5 times the standard potentiometer torque. For all detents versions of more than 13 detents the detent torque will be 0.5 to 3.5 Ncm

STEPPED OUTPUTS / CONSTANT VALUE ZONES

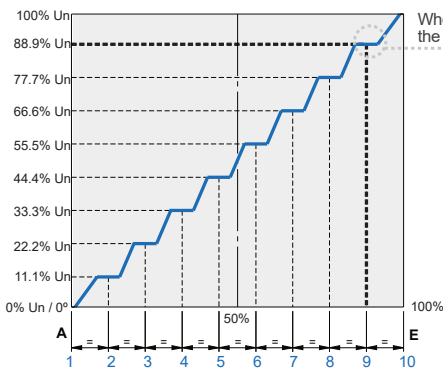

When the potentiometer's wiper is located at detent n°9, the output voltage will be 88.9% Un ±% tolerance.

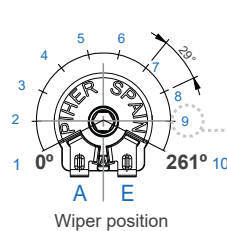

IMPROVED REPEATABILITY

Constant value zones can be combined with strategically located mechanical detents to provide exact alignment between the electrical output (flat areas) and the mechanical detent position. This provides clear mechanical positions that are not only repeatable, but perfectly aligned electrical outputs at each of the (detent) angles. The detents also prevent output values from changing due to vibration or accidental rotor movements. The result is a higher level of precision in controlling lighting, temperature, motor or other electronic control systems.

Contact Piher Sensing Systems for ordering information.

PS-15 / PSC-15

15-mm carbon / cermet SMD potentiometer

POSITIONING

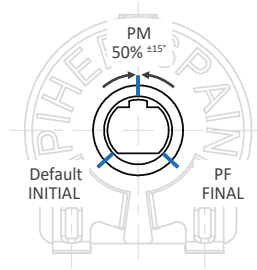

Special delivery positions available on request.

PACKAGING

Bulk (500 units per box)



Dimensions (mm): 185x85x80

Reel - embossed tape (500 pcs/reel)

