

# PSC-360

## Hall-Effect End-of-Shaft Rotary Position Sensor



Available with  
**CAN**

### KEY FEATURES



#### True, contactless operation

Without any gears or mechanical interfaces the sensor is easily assembled and calibrated and subject to limited wear and tear over lifetime.

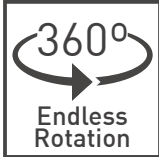

#### 360 degree absolute position feedback

Endless mechanical rotational angle without dead band, keeps the position on power loss with programmable electrical angles from 15 to 360 degrees.



#### Made for harsh environments

The rugged package protects the sensor from dust, moisture, vibration and extreme temperatures for usage in the most demanding environments.



#### Durable and robust design

The non-contacting design allows for an extra-long product lifetime of up to 50 million cycles.



#### Integrated shaft

The magnet is securely fastened to the shaft and acts as only moving component in the sensor.



#### Adaptable to your requirements

Programmable transfer function and switch outputs as well as different output protocols and redundancy levels available.

### DESCRIPTION

The robust PSC-360 is a cost-effective non-contacting rotary position sensor that provides high performance in harsh environments such as transportation, industrial and medical applications.

This compact sensor of Piher Sensing Systems is truly non-contacting with a permanent magnet that is securely fastened to the shaft and acts as the only moving component in the sensor. Redundant versions provide independent voltage outputs with fully customizable characteristics. Additionally a switch output can optionally be configured.

The endless rotation sensor is highly configurable with a programmable angular range between 15 and 360 degrees, different signal output options and support for low and high-voltage power supply. Sealed, flange mounted for easy positioning and with fly leads, it can be customized to fit any desired connector configuration.

Multi-turn configurations are available on request.

### APPLICATIONS

#### Industrial

- ▶ Autonomous warehouse robotics
- ▶ Robotics and automation feedback
- ▶ Robot arm position
- ▶ Valve monitoring
- ▶ Conveyor operation

#### Transportation

- ▶ Steering wheel angle
- ▶ Pedal Position
- ▶ Suspension/height detection
- ▶ Fork height and mast tilt
- ▶ Bucket position
- ▶ Hitch position
- ▶ Transmission gear shift

#### Marine

- ▶ Steering and shifter sensor

#### Home and Building Automation

- ▶ HVAC systems

# PSC-360

## Hall-Effect End-of-Shaft Rotary Position Sensor

### MECHANICAL SPECIFICATIONS

	PSC-360	PSC-360U
Rotational life	Up to 50.000.000 cycles	
Mechanical range	360° (endless rotation)	
Shaft diameter	6mm	6,35mm

### ELECTRICAL SPECIFICATIONS

	PSC-360	PSC-360U
Linearity <sup>1</sup>	±1% absolute (±0.5% on request)	
Electrical angular range	Programmable from 15° to 360°	
Output protocols	Analog (Ratiometric), PWM Serial Protocol (SPI) upon request CAN SAE J1939 CAN OPEN	Analog (Ratiometric), PWM Serial Protocol (SPI)
Output	Simple Redundant Full-redundant	
Switch output	On request	Configurable
Resolution	CAN, Analog, PWM SPI	Up to 12 bit Up to 14 bit
Supply voltage <sup>2</sup>	5V ±10% 7V to 15V	5V ±10% 12V ±10% 15V ±10%
Supply current	Single version Redundant version CAN version	Typ 8.5 mA Typ 17 mA Typ 47 mA
Voltage protection	±10V	
Self-diagnostic features	yes	

<sup>1</sup> Ferromagnetic materials close to the sensor (i.e. shaft, mounting surface) may affect the sensor's linearity.

<sup>2</sup> Voltages up to 25V possible on request.

### ENVIRONMENTAL SPECIFICATIONS

Operating and storage temperature <sup>1</sup>	-40° to +125°C
Shock	50g
Vibration	5-2000 Hz; 20g; Amax 0,75 mm

<sup>1</sup> Other specifications available

# PSC-360

## Hall-Effect End-of-Shaft Rotary Position Sensor

### DIMENSIONS (MM)

PSC-360G2

PSC-360U - panel mount version

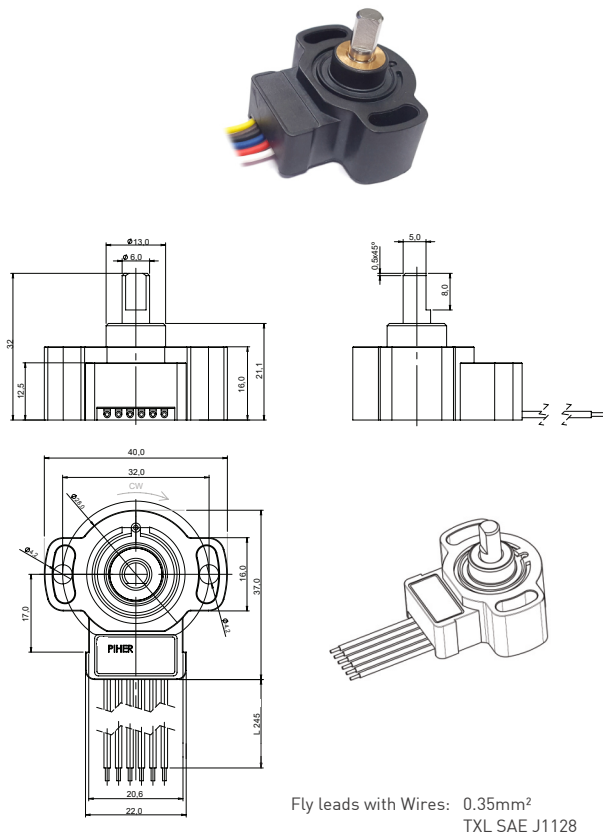

Sensor shown with the shaft at zero position.

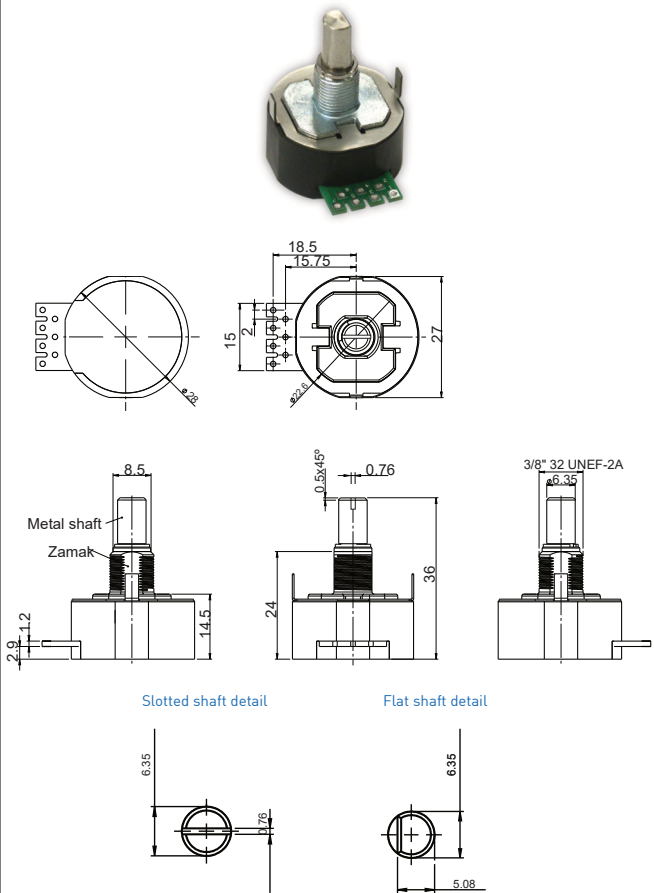

Sensor shown with the shaft at 0° position. Nut and washer included.



Download the STEP's file here:  
[www.pihernet.net](http://www.pihernet.net)

Sensor delivered at random position. Assembly of any type of connector on request.

### MOUNTING INSTRUCTIONS

1. Place the component on a flat surface.
2. Fit the actuator onto the shaft avoiding any mechanical play/wobble.
3. Fasten the two M4 screws (M4 washers are recommended).

### CONNECTION SCHEME

Color	Simple		Redundant		Full-redundant	CAN	SPI
	5V	7V to 15V	5V	7V to 15V			
Brown	Power supply	Power supply	Power supply	Power supply	Power supply 1	Power supply	Power supply
Blue	Ground	Ground	Ground	Ground	Ground 1	Ground	Ground
Black	Signal output	Signal output	Signal output 1	Signal output 1	Ground 2	CAN High	MOSI
White	n/a	n/a	Signal output 2	Signal output 2	Signal output 2	CAN Low	/SS
Red	n/a	n/a	n/a	n/a	Power supply 2	n/a	n/a
Yellow	n/a	n/a	n/a	n/a	Signal output 1	n/a	n/a
Grey	n/a	Not used	n/a	Not used	n/a	n/a	SCLK

More instructions of use on [www.pihernet.net](http://www.pihernet.net). Connector assembly available on request.

# PSC-360

## Hall-Effect End-of-Shaft Rotary Position Sensor



### HOW TO ORDER (Example: PSC360G2-F1A-C0001-ERA360-05K)

#### Simple Output - Analogic, PWM and CAN

PSC360G2	-	F	1	-	-	C_____	-	ERA_____	-	___	K	-	_____
Series	Shaft	Type	Output <sup>1</sup>	Output function <sup>2</sup>	Electric rotational angle <sup>3</sup>	Voltage supply <sup>4</sup>	Temp. range	PWM Frequency Hz <sup>5</sup>					
	F = flat	1 = simple	A = analogic P = PWM J = CAN SAE J1939 O = CAN OPEN	C0000 C0001	ERA040 ERA041 ... ERA360	05 = 5V ±10% RE = 7V-15V	K = -40°C to +125°C	[empty] = 200Hz F100 = 100Hz F101 = 101Hz ... F999 = 999Hz					

#### Redundant output - Analogic, PWM and CAN

PSC360G2	-	F	2	-	-	C_____	-	ERA_____	-	___	K	-	_____	_____
Series	Shaft	Type	Output <sup>1</sup>	Output function <sup>2</sup>	Electric rotational angle <sup>3</sup>	Voltage supply <sup>4</sup>	Temp. range	PWM Frequency Hz. (1) <sup>5</sup>	PWM Frequency Hz. (2) <sup>5</sup>					
	F = flat	2 = redundant	AA= analogic PP = PWM JJ = CAN SAE J1939 OO = CAN OPEN	C0002	ERA040 ERA041 ... ERA360	05 = 5V ±10% RE = 7V-15V	K = -40°C to +125°C	F100 F101 ... F999	F100 F101 ... F999					

#### Full-redundant output - Analogic and PWM

PSC360G2	-	F	3	-	-	C_____	-	ERA_____	-	05	K	-	_____	_____
Series	Shaft	Type	Output <sup>1</sup>	Output function <sup>2</sup>	Electric rotational angle <sup>3</sup>	Voltage supply <sup>4</sup>	Temp. range	PWM Frequency Hz. (1) <sup>4</sup>	PWM Frequency Hz. (2) <sup>4</sup>					
	F = flat	3 = full-redundant	AA= analogic PP = PWM	C0002	ERA040 ERA041 ... ERA360	05 = 5V ±10%	K = -40°C to +125°C	F100 F101 ... F999	F100 F101 ... F999					

1 The analog output is ratiometric, proportional:  
 - for supply voltage "5V" to input voltage;  
 - for supply voltage "RE" to 5V.  
 2 Other output functions available, please check availability. Enter CXXXX as long as the new output function is not defined.  
 3 Models with ERA < 40° available on request  
 4 Voltages up to 25V possible on request.  
 5 Leave empty if not applicable. Default frequency is 200 Hz

### OUTPUT FUNCTIONS

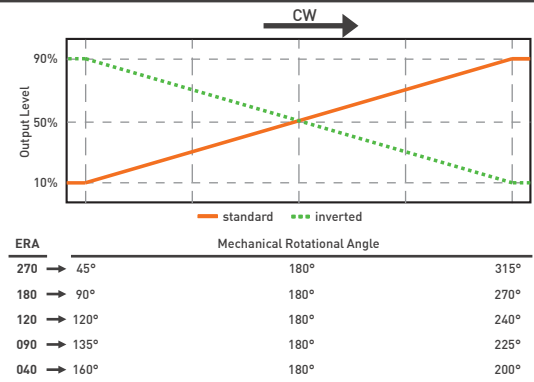

ERA	Standard	Inverted	Redundant
360°	C0000	C0001	C0002
270°	C0208	C0158	C0031
180°	C0007	C0072	C0036
120°	C0024	On request	C0032
90°	C0011		C0025
70°	C0150		C0149
60°	C0006		C0020
40°	C0026		C0123

Custom output functions on request.

# PSC-360U Panel Mount Version



## HOW TO ORDER - PANEL MOUNT VERSION (Example: PSC360U-F1A-C0000-ERA360-05E)

### Simple Output - Analogic and PWM

PSC360U	-	-	1	-	-	-	-	C	ERA	-	-	-	-
Series	Shaft	Type	Output <sup>1</sup>	Switch	Switch position <sup>2</sup>	Output function <sup>3</sup>	Electric rotational angle <sup>4</sup>	Voltage supply	Temp. range	PWM Frequency Hz <sup>5</sup>			
	F = flat shaft L = slot shaft	1 = simple	A = analogic P = PWM	[empty] = none W = switch	[empty] 000 016 ... 360	C0000 C0001	ERA040 ERA041 ... ERA360	05 = 5V 12 = 12V 15 = 15V	E = -40°C to +85°C K = -40°C to +125°C	[empty] = 200Hz F100 = 100Hz F101 = 101Hz ... F999 = 999Hz			

### Simple output - SPI

PSC360U	-	-	1	S	C	ERA	-	-	-
Series	Shaft	Type	Output	Output function <sup>3</sup>	Electric rotational angle <sup>4</sup>	Voltage supply	Temp. range		
	F = flat shaft L = slot shaft	1 = simple	S = SPI	C0000 C0001	ERA040 ERA041 ... ERA360	05 = 5V 12 = 12V 15 = 15V	E = -40°C to +85°C K = -40°C to +125°C		

#### Annotations:

- The analog output is ratiometric, proportional:
  - For supply voltage 5V: to input supply voltage.
  - For supply voltage 12V and 15V: to 5V.
- Leave empty if not applicable. Switch function diagram: see next page.
- Other output functions available, please check availability. Enter CXXX as long as the new output function is not defined.
- Models with ERA < 40° available on request
- Leave empty if not applicable. Default frequency is 200 Hz

### Redundant output - Analogic and PWM

PSC360U	-	-	2	-	-	-	-	-	C	ERA	-	-	-	-
Series	Shaft	Type	Output <sup>1</sup>	Switch1	Switch1 position <sup>2</sup>	Switch2	Switch2 position <sup>2</sup>	Output function <sup>3</sup>	Electric rotational angle <sup>4</sup>	Voltage supply	Temp. range	PWM Frequency Hz. (1) <sup>5</sup>	PWM Frequency Hz. (2) <sup>5</sup>	
	F = flat shaft L = slot shaft	2 = redundant	AA= analogic PP = PWM	[empty] = none W = switch	[empty] 000 016 ... 360	[empty] = none W = switch	[empty] 000 016 ... 360	C0002 C0003	ERA040 ERA041 ... ERA360	05 = 5V 12 = 12V 15 = 15V	E = -40°C to +85°C K = -40°C to +125°C	F100 F101 ... F999	F100 F101 ... F999	

### Full-redundant output - Analogic and PWM

PSC360U	-	-	3	-	-	-	-	-	C	ERA	-	-	-	-
Series	Shaft	Type	Output <sup>1</sup>	Switch1	Switch1 position <sup>2</sup>	Switch2	Switch2 position <sup>2</sup>	Output function <sup>3</sup>	Electric rotational angle <sup>4</sup>	Voltage supply	Temp. range	PWM Frequency Hz. (1) <sup>5</sup>	PWM Frequency Hz. (2) <sup>5</sup>	
	F = flat shaft L = slot shaft	3 = redundant	AA= analogic PP = PWM	[empty] = none W = switch	[empty] 000 016 ... 360	[empty] = none W = switch	[empty] 000 016 ... 360	C0002 C0003	ERA040 ERA041 ... ERA360	05 = 5V	E = -40°C to +85°C K = -40°C to +125°C	F100 F101 ... F999	F100 F101 ... F999	