

PSC-360

Hall-Effect End-of-Shaft Rotary Position Sensor

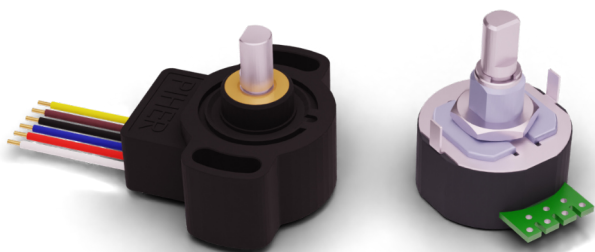

Available with
CAN

KEY FEATURES



True, contactless operation

Without any gears or mechanical interfaces the sensor is easily assembled and calibrated and subject to limited wear and tear over lifetime.

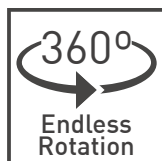

360 degree absolute position feedback

Endless mechanical rotational angle without dead band, keeps the position on power loss with programmable electrical angles from 15 to 360 degrees.



Made for harsh environments

The rugged package protects the sensor from dust, moisture, vibration and extreme temperatures for usage in the most demanding environments.



Durable and robust design

The non-contacting design allows for an extra-long product lifetime of up to 50 million cycles.

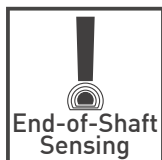

Integrated shaft

The magnet is securely fastened to the shaft and acts as only moving component in the sensor.



Adaptable to your requirements

Programmable transfer function and switch outputs as well as different output protocols and redundancy levels available.

DESCRIPTION

The robust PSC-360 is a cost-effective non-contacting rotary position sensor that provides high performance in harsh environments such as transportation, industrial and medical applications.

This compact sensor of Piher Sensing Systems is truly non-contacting with a permanent magnet that is securely fastened to the shaft and acts as the only moving component in the sensor. Redundant versions provide independent voltage outputs with fully customizable characteristics. Additionally a switch output can optionally be configured.

The endless rotation sensor is highly configurable with a programmable angular range between 15 and 360 degrees, different signal output options and support for low and high-voltage power supply. Sealed, flange mounted for easy positioning and with fly leads, it can be customized to fit any desired connector configuration.

Multi-turn configurations are available on request.

APPLICATIONS

Industrial

- ▶ Autonomous warehouse robotics
- ▶ Robotics and automation feedback
- ▶ Robot arm position
- ▶ Valve monitoring
- ▶ Conveyor operation

Transportation

- ▶ Steering wheel angle
- ▶ Pedal Position
- ▶ Suspension/height detection
- ▶ Fork height and mast tilt
- ▶ Bucket position
- ▶ Hitch position
- ▶ Transmission gear shift

Marine

- ▶ Steering and shifter sensor

Home and Building Automation

- ▶ HVAC systems

PSC-360

Hall-Effect End-of-Shaft Rotary Position Sensor

MECHANICAL SPECIFICATIONS

	PSC-360	PSC-360U
Rotational life	Up to 50.000.000 cycles	
Mechanical range	360° (endless rotation)	
Shaft diameter	6mm	6,35mm

ELECTRICAL SPECIFICATIONS

	PSC-360	PSC-360U
Linearity ¹	±1% absolute (±0.5% on request)	
Electrical angular range	Programmable from 15° to 360°	
Output protocols	Analog (Ratiometric), PWM Serial Protocol (SPI) upon request CAN SAE J1939 CAN OPEN	Analog (Ratiometric), PWM Serial Protocol (SPI)
Output	Simple Redundant Full-redundant	
Switch output	On request	Configurable
Resolution	CAN, Analog, PWM SPI	Up to 12 bit Up to 14 bit
Supply voltage ²	5V ±10% 7V to 15V	5V ±10% 12V ±10% 15V ±10%
Supply current	Single version Redundant version CAN version	Typ 8.5 mA Typ 17 mA Typ 47 mA
Voltage protection	±10V	
Self-diagnostic features	yes	

¹ Ferromagnetic materials close to the sensor (i.e. shaft, mounting surface) may affect the sensor's linearity.

² Voltages up to 25V possible on request.

ENVIRONMENTAL SPECIFICATIONS

Operating and storage temperature ¹	-40° to +125°C
Shock	50g
Vibration	5-2000 Hz; 20g; Amax 0,75 mm

¹ Other specifications available

PSC-360

Hall-Effect End-of-Shaft Rotary Position Sensor

DIMENSIONS (MM)

PSC-360G2

PSC-360U - panel mount version

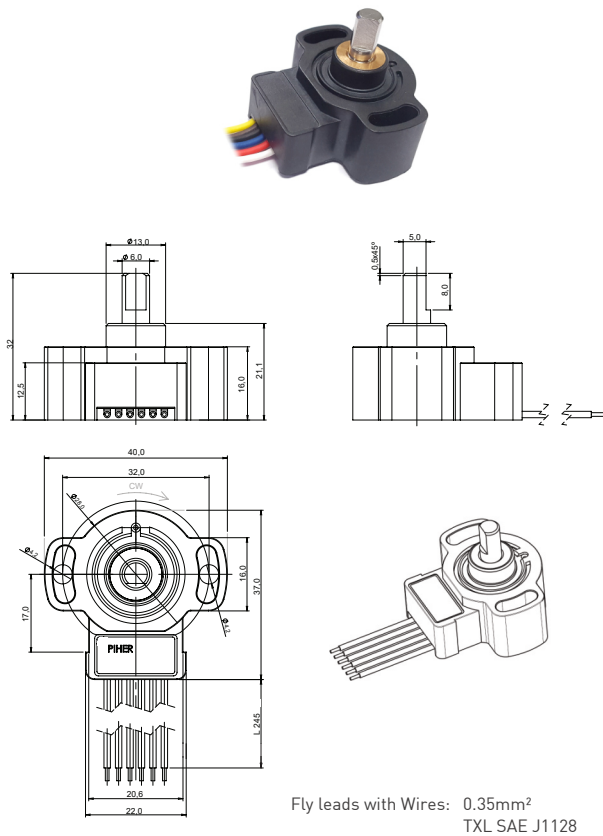

Sensor shown with the shaft at zero position.

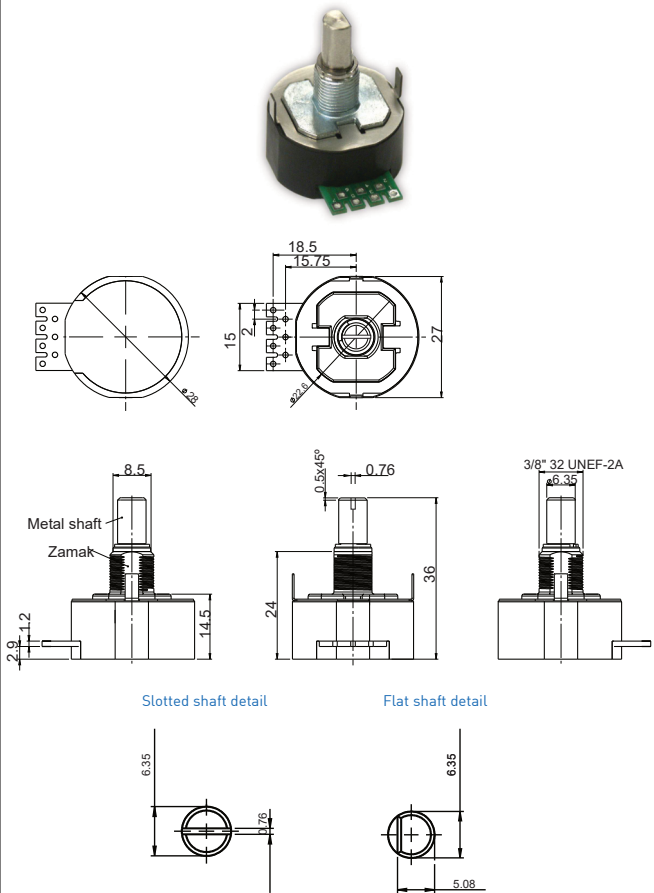

Sensor shown with the shaft at 0° position. Nut and washer included.



Download the STEP's file here:
www.pihernet.net

Sensor delivered at random position. Assembly of any type of connector on request.

MOUNTING INSTRUCTIONS

1. Place the component on a flat surface.
2. Fit the actuator onto the shaft avoiding any mechanical play/wobble.
3. Fasten the two M4 screws (M4 washers are recommended).

CONNECTION SCHEME

Color	Simple		Redundant		Full-redundant	CAN	SPI
	5V	7V to 15V	5V	7V to 15V			
Brown	Power supply	Power supply	Power supply	Power supply	Power supply 1	Power supply	Power supply
Blue	Ground	Ground	Ground	Ground	Ground 1	Ground	Ground
Black	Signal output	Signal output	Signal output 1	Signal output 1	Ground 2	CAN High	MOSI
White	n/a	n/a	Signal output 2	Signal output 2	Signal output 2	CAN Low	/SS
Red	n/a	n/a	n/a	n/a	Power supply 2	n/a	n/a
Yellow	n/a	n/a	n/a	n/a	Signal output 1	n/a	n/a
Grey	n/a	Not used	n/a	Not used	n/a	n/a	SCLK

More instructions of use on www.pihernet.net. Connector assembly available on request.

PSC-360

Hall-Effect End-of-Shaft Rotary Position Sensor



HOW TO ORDER (Example: PSC360G2-F1A-C0001-ERA360-05K)

Simple Output - Analogic, PWM and CAN

PSC360G2	-	F	1	-	-	C_____	-	ERA_____	-	___	K	-	_____
Series	Shaft	Type	Output ¹	Output function ²	Electric rotational angle ³	Voltage supply ⁴	Temp. range	PWM Frequency Hz ⁵					
	F = flat	1 = simple	A = analogic P = PWM J = CAN SAE J1939 O = CAN OPEN	C0000 C0001	ERA040 ERA041 ... ERA360	05 = 5V ±10% RE = 7V-15V	K = -40°C to +125°C	[empty] = 200Hz F100 = 100Hz F101 = 101Hz ... F999 = 999Hz					

Redundant output - Analogic, PWM and CAN

PSC360G2	-	F	2	-	-	C_____	-	ERA_____	-	___	K	-	_____	_____
Series	Shaft	Type	Output ¹	Output function ²	Electric rotational angle ³	Voltage supply ⁴	Temp. range	PWM Frequency Hz. (1) ⁵	PWM Frequency Hz. (2) ⁵					
	F = flat	2 = redundant	AA= analogic PP = PWM JJ = CAN SAE J1939 OO = CAN OPEN	C0002	ERA040 ERA041 ... ERA360	05 = 5V ±10% RE = 7V-15V	K = -40°C to +125°C	F100 F101 ... F999	F100 F101 ... F999					

Full-redundant output - Analogic and PWM

PSC360G2	-	F	3	-	-	C_____	-	ERA_____	-	05	K	-	_____	_____
Series	Shaft	Type	Output ¹	Output function ²	Electric rotational angle ³	Voltage supply ⁴	Temp. range	PWM Frequency Hz. (1) ⁴	PWM Frequency Hz. (2) ⁴					
	F = flat	3 = full-redundant	AA= analogic PP = PWM	C0002	ERA040 ERA041 ... ERA360	05 = 5V ±10%	K = -40°C to +125°C	F100 F101 ... F999	F100 F101 ... F999					

1 The analog output is ratiometric, proportional:
 - for supply voltage "5V" to input voltage;
 - for supply voltage "RE" to 5V.
 2 Other output functions available, please check availability. Enter CXXXX as long as the new output function is not defined.
 3 Models with ERA < 40° available on request
 4 Voltages up to 25V possible on request.
 5 Leave empty if not applicable. Default frequency is 200 Hz

OUTPUT FUNCTIONS

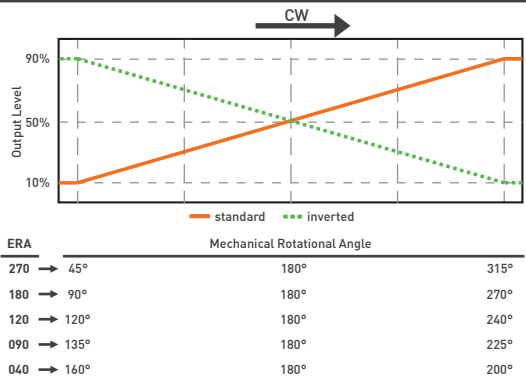

ERA	Standard	Inverted	Redundant
360°	C0000	C0001	C0002
270°	C0208	C0158	C0031
180°	C0007	C0072	C0036
120°	C0024	On request	C0032
90°	C0011		C0025
70°	C0150		C0149
60°	C0006		C0020
40°	C0026		C0123

Custom output functions on request.

PSC-360U Panel Mount Version



HOW TO ORDER - PANEL MOUNT VERSION (Example: PSC360U-F1A-C0000-ERA360-05E)

Simple Output - Analogic and PWM

PSC360U	-	-	1	-	-	-	-	C	----	ERA	----	-	-	-	----
Series	Shaft	Type	Output ¹	Switch	Switch position ²	Output function ³	Electric rotational angle ⁴	Voltage supply	Temp. range	PWM Frequency Hz ⁵					
	F = flat shaft L = slot shaft	1 = simple	A = analogic P = PWM	[empty] = none W = switch	[empty] 000 016 ... 360	C0000 C0001	ERA040 ERA041 ... ERA360	05 = 5V 12 = 12V 15 = 15V	E = -40°C to +85°C K = -40°C to +125°C	[empty] = 200Hz F100 = 100Hz F101 = 101Hz ... F999 = 999Hz					

Simple output - SPI

PSC360U	-	-	1	S	-	C	----	ERA	----	-	-	-
Series	Shaft	Type	Output	Output function ³	Electric rotational angle ⁴	Voltage supply	Temp. range					
	F = flat shaft L = slot shaft	1 = simple	S = SPI	C0000 C0001	ERA040 ERA041 ... ERA360	05 = 5V 12 = 12V 15 = 15V	E = -40°C to +85°C K = -40°C to +125°C					

Annotations:

- The analog output is ratiometric, proportional:
 - For supply voltage 5V: to input supply voltage.
 - For supply voltage 12V and 15V: to 5V.
- Leave empty if not applicable. Switch function diagram: see next page.
- Other output functions available, please check availability. Enter CXXX as long as the new output function is not defined.
- Models with ERA < 40° available on request
- Leave empty if not applicable. Default frequency is 200 Hz

Redundant output - Analogic and PWM

PSC360U	-	-	2	-	-	-	-	-	-	C	----	ERA	----	-	-	-	----	----
Series	Shaft	Type	Output ¹	Switch1	Switch1 position ²	Switch2	Switch2 position ²	Output function ³	Electric rotational angle ⁴	Voltage supply	Temp. range	PWM Frequency Hz. (1) ⁵	PWM Frequency Hz. (2) ⁵					
	F = flat shaft L = slot shaft	2 = redundant	AA= analogic PP = PWM	[empty] = none W = switch	[empty] 000 016 ... 360	[empty] = none W = switch	[empty] 000 016 ... 360	C0002 C0003	ERA040 ERA041 ... ERA360	05 = 5V 12 = 12V 15 = 15V	E = -40°C to +85°C K = -40°C to +125°C	F100 F101 ... F999	F100 F101 ... F999					

Full-redundant output - Analogic and PWM

PSC360U	-	-	3	-	-	-	-	-	-	C	----	ERA	----	-	-	-	----	----
Series	Shaft	Type	Output ¹	Switch1	Switch1 position ²	Switch2	Switch2 position ²	Output function ³	Electric rotational angle ⁴	Voltage supply	Temp. range	PWM Frequency Hz. (1) ⁵	PWM Frequency Hz. (2) ⁵					
	F = flat shaft L = slot shaft	3 = redundant	AA= analogic PP = PWM	[empty] = none W = switch	[empty] 000 016 ... 360	[empty] = none W = switch	[empty] 000 016 ... 360	C0002 C0003	ERA040 ERA041 ... ERA360	05 = 5V	E = -40°C to +85°C K = -40°C to +125°C	F100 F101 ... F999	F100 F101 ... F999					