

PTAB182002FC

Thermally-Enhanced High Power RF LDMOS FET 190 W, 28 V, 1805 – 1880 MHz

Description

The PTAB182002FC is a 190-watt LDMOS FET intended for use in multi-standard cellular power amplifier applications in the 1805 to 1880 MHz frequency band. Features include input and output matching, high gain and thermally-enhanced package with earless flange. Manufactured with Wolfspeed's advanced LDMOS process, this device provides excellent thermal performance and superior reliability.

PTAB182002FC
Package H-37248-4

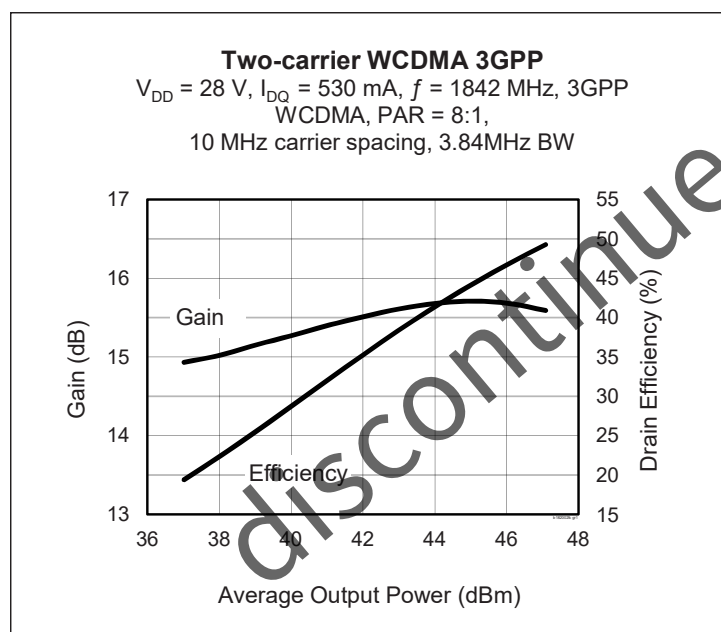

Features

- Asymmetric Doherty design
 - Main: $P_{1dB} = 70\text{ W Typ}$
 - Peak: $P_{1dB} = 120\text{ W Typ}$
- Broadband internal matching
- Typical two-carrier WCDMA performance at 1842 MHz, 28 V (Doherty configuration)
 - Average output power = 44.6 dBm
 - Linear Gain = 15.5 dB
 - Efficiency = 46%
 - IMD = -25 dBc
- Increased negative gate-source voltage range for improved performance in Doherty amplifiers
- Integrated ESD protection
- Capable of handling 3:1 VSWR @ 30 V, 50 W (average) output power (one-carrier WCDMA signal, 10 dB PAR, Doherty test fixture)
- Pb-free and RoHS-compliant

RF Characteristics

Two-carrier WCDMA Measurements (tested in Wolfspeed Doherty test fixture)

$V_{DD} = 28\text{ V}$, $V_{GSPK} = (V_{GS} \text{ at } I_{DQ} = 900\text{ mA}) - 1.80\text{ V}$, $I_{DQ} = 520\text{ mA}$, $P_{OUT} = 29\text{ W avg.}$, $f_1 = 1870\text{ MHz}$, $f_2 = 1880\text{ MHz}$, 7.5 dB PAR

Characteristic	Symbol	Min	Typ	Max	Unit
Gain	G_{ps}	14.5	15.5	—	dB
Drain Efficiency	η_D	42	44	—	%
Intermodulation Distortion	IMD	—	-26.5	-24	dBc

All published data at $T_{CASE} = 25^\circ\text{C}$ unless otherwise indicated

ESD: Electrostatic discharge sensitive device—observe handling precautions!

DC Characteristics

Characteristic	Conditions	Symbol	Min	Typ	Max	Unit
Drain-source Breakdown Voltage	$V_{GS} = 0\text{ V}, I_{DS} = 10\text{ mA}$	$V_{(BR)DSS}$	65	—	—	V
Drain Leakage Current	$V_{DS} = 28\text{ V}, V_{GS} = 0\text{ V}$	I_{DSS}	—	—	1.0	μA
	$V_{DS} = 63\text{ V}, V_{GS} = 0\text{ V}$	I_{DSS}	—	—	10.0	μA
On-state Resistance (main)	$V_{GS} = 10\text{ V}, V_{DS} = 0.1\text{ V}$	$R_{DS(on)}$	—	0.15	—	Ω
On-state Resistance (peak)	$V_{GS} = 10\text{ V}, V_{DS} = 0.1\text{ V}$	$R_{DS(on)}$	—	0.09	—	Ω
Operating Gate Voltage (main)	$V_{DS} = 28\text{ V}, I_{DQ} = 520\text{ mA}$	V_{GS}	2.5	3.0	3.5	V
Operating Gate Voltage (peak)	$V_{DS} = 28\text{ V}, I_{DQ} = 0\text{ mA}$	V_{GS}	0.7	1.1	1.5	V
Gate Leakage Current	$V_{GS} = 10\text{ V}, V_{DS} = 0\text{ V}$	I_{GSS}	—	—	1.0	μA

Maximum Ratings

Parameter	Symbol	Value	Unit
Drain-source Voltage	V_{DSS}	65	V
Gate-source Voltage	V_{GS}	-6 to +10	V
Junction Temperature	T_J	200	$^{\circ}\text{C}$
Storage Temperature Range	T_{STG}	-40 to +150	$^{\circ}\text{C}$
Thermal Resistance (main, $T_{CASE} = 70^{\circ}\text{C}$, 80 W CW class AB)	$R_{\theta JC}$	0.86	$^{\circ}\text{C}/\text{W}$
	$R_{\theta JC}$	0.64	$^{\circ}\text{C}/\text{W}$
(peak, $T_{CASE} = 70^{\circ}\text{C}$, 110 W CW class C)			

Ordering Information

Type and Version	Order Code	Package and Description	Shipping
PTAB182002FC V1 R0	PTAB182002FC-V1-R0	H-37248-4, ceramic open-cavity, earless flange	Tape & Reel, 50 pcs
PTAB182002FC V1 R250	PTAB182002FC-V1-R250	H-37248-4, ceramic open-cavity, earless flange	Tape & Reel, 250 pcs

Typical Performance (data taken in a production Doherty test fixture)

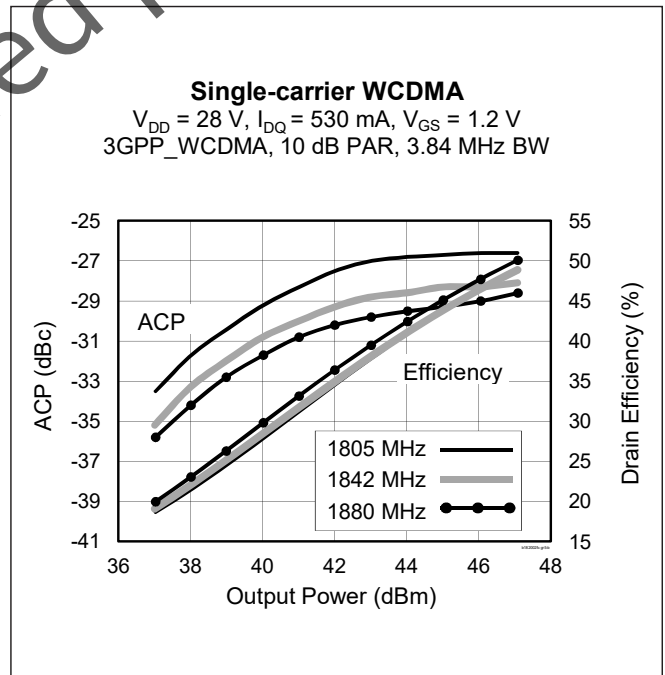
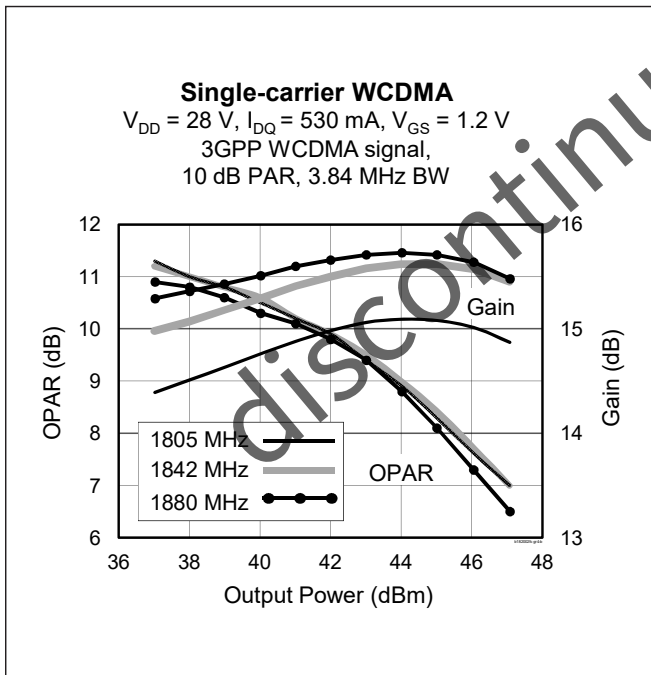
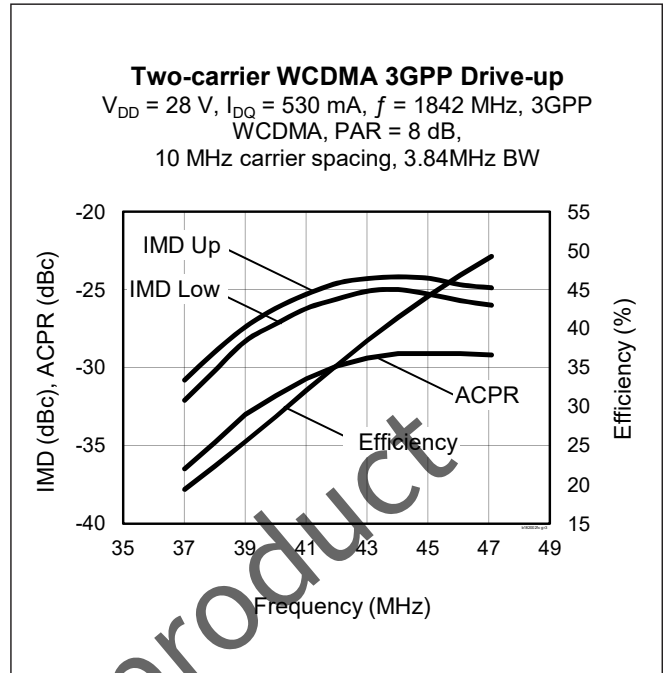
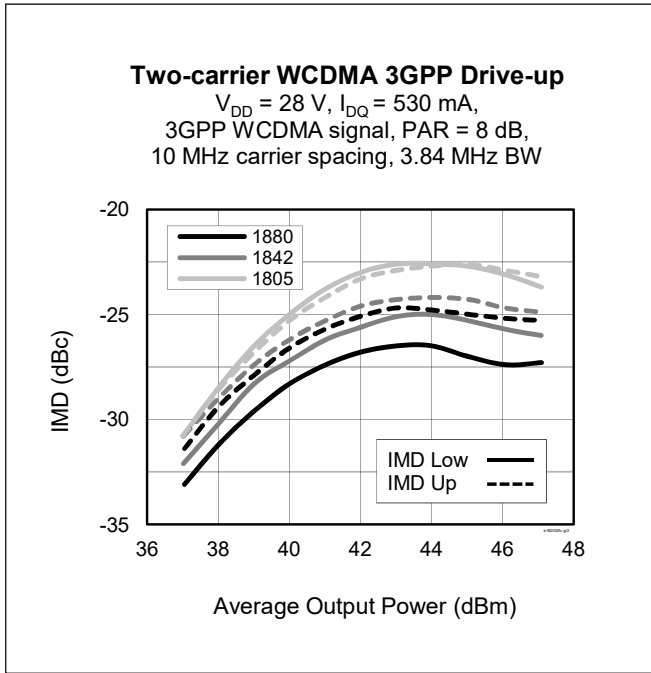

Typical Performance (cont.)

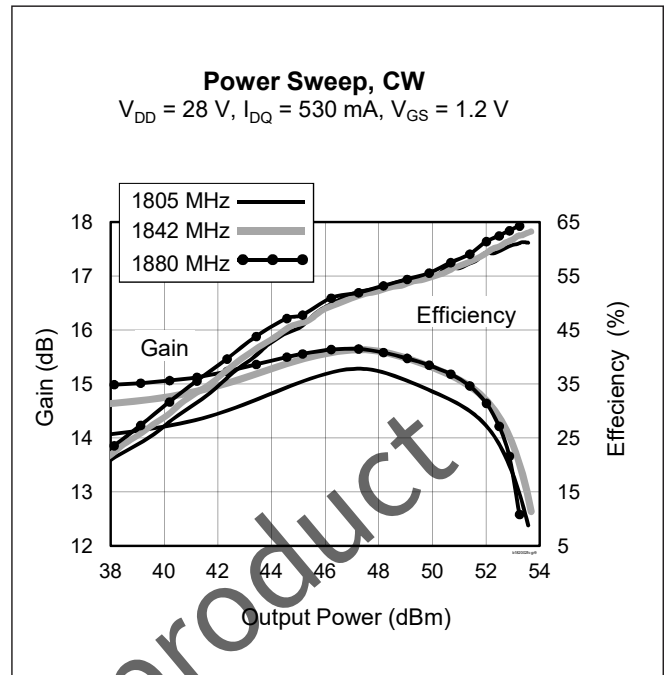
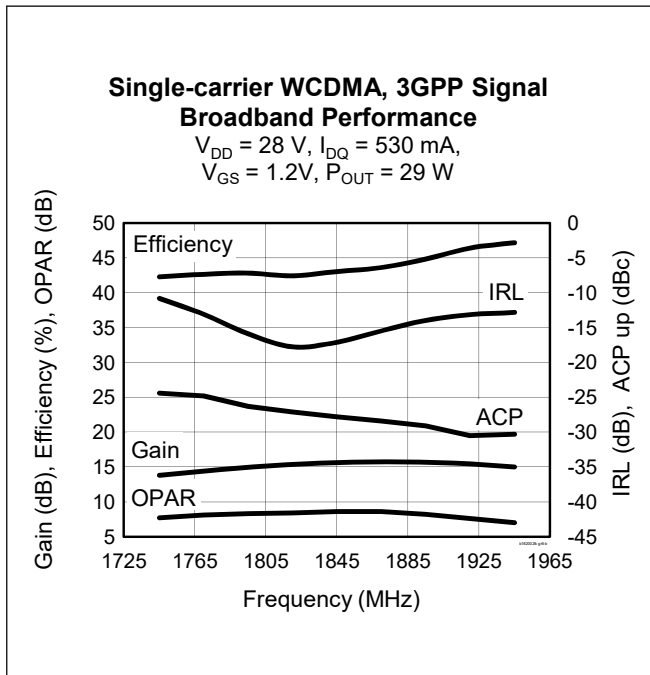

Load Pull Performance

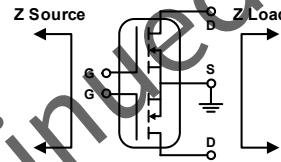

Main Side Load Pull Performance – Pulsed CW signal: 12 μsec , 10% duty cycle; 28 V, 530 mA

Class AB		P_{1dB}									
		Max Output Power					Max PAE				
Freq [MHz]	$Z_s \Omega$	$Z_l \Omega$	Gain [dB]	P_{OUT} [dBm]	P_{OUT} [W]	PAE %	$Z_l \Omega$	Gain [dB]	P_{OUT} [dBm]	P_{OUT} [W]	PAE %
1805	5.9 – j9.5	2.8 – j5.4	17.4	50.50	112	56.0	6.1 – j6.3	19.7	48.63	73	67.0
1842	7.5 – j9.7	2.7 – j5.7	17.2	50.26	106	54.4	6.9 – j4.8	20.0	48.08	64	66.2
1880	9.5 – j10.3	3.0 – j5.7	17.8	50.28	107	56.1	6.7 – j5.2	20.1	48.38	69	66.3

Peak Side Load Pull Performance – Pulsed CW signal: 12 μsec , 10% duty cycle; 28 V, 10 mA

Class C		P_{1dB}									
		Max Output Power					Max PAE				
Freq [MHz]	$Z_s \Omega$	$Z_l \Omega$	Gain [dB]	P_{OUT} [dBm]	P_{OUT} [W]	PAE %	$Z_l \Omega$	Gain [dB]	P_{OUT} [dBm]	P_{OUT} [W]	PAE %
1805	11.0 – j6.1	1.3 – j5.5	15.7	52.43	175	54.4	2.8 – j4.5	17.7	50.60	115	70.2
1842	8.0 – j4.8	1.3 – j5.8	16.2	52.38	173	54.7	2.7 – j4.7	17.8	50.50	112	69.0
1880	6.7 – j2.4	1.4 – j6.0	16.8	52.33	171	54.9	2.7 – j4.8	18.0	50.40	110	68.5

Reference Circuit

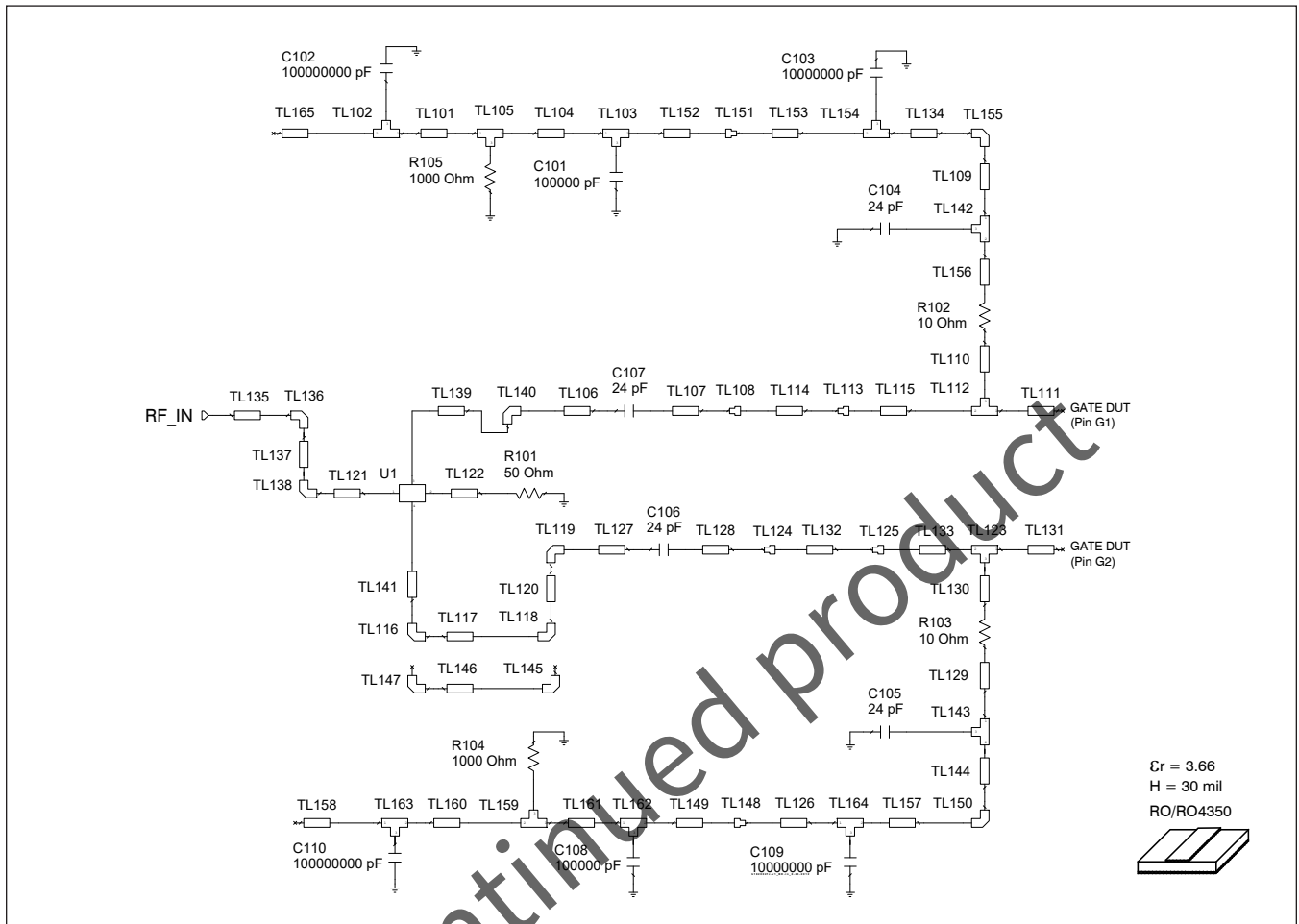

Reference circuit input schematic for $f = 1880$ MHz

Reference Circuit (cont.)

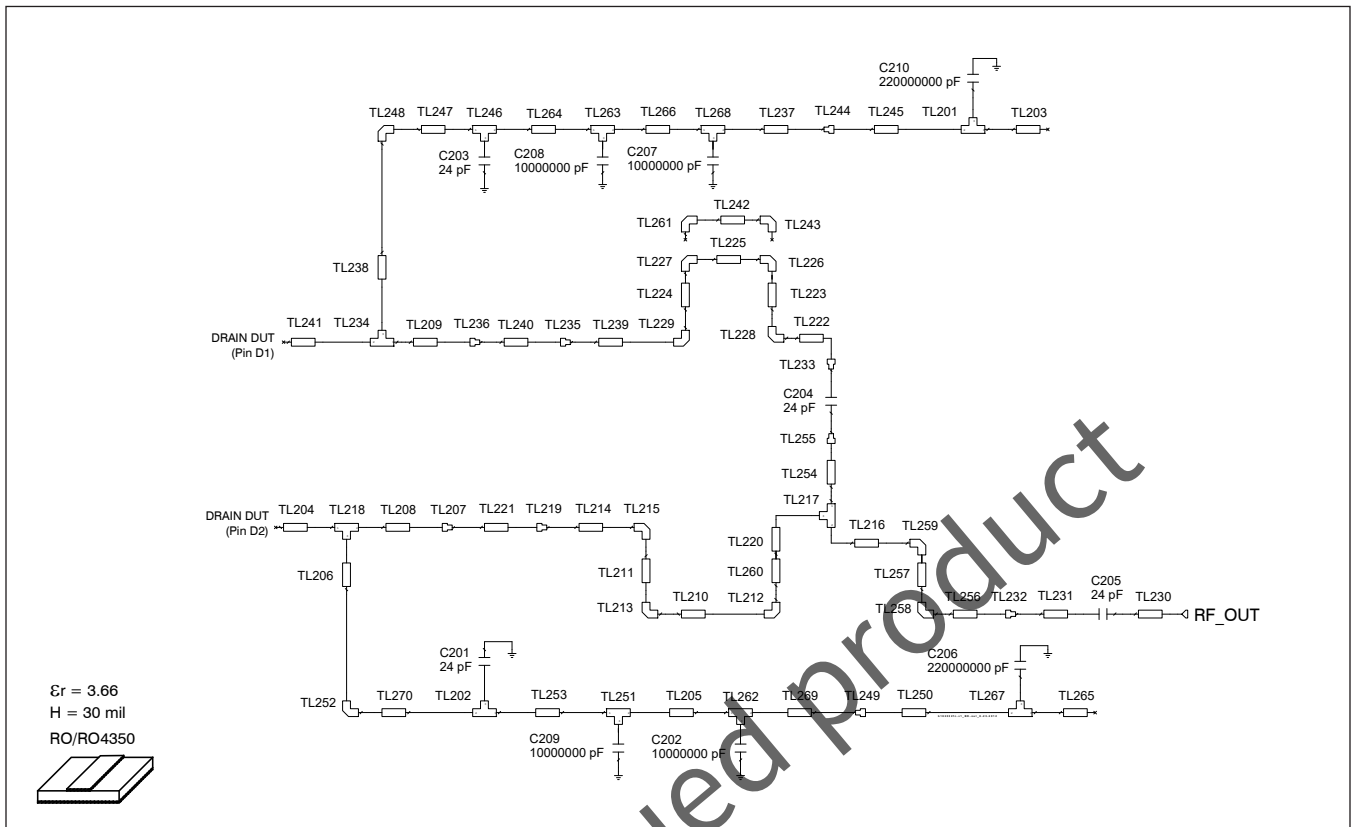

Reference circuit output schematic for $f = 1880 \text{ MHz}$

Reference Circuit

DUT	PTAB182002FC
Test Fixture Part No.	LTA/PTAB182002FC
PCB	Rogers 4350, 0.762 mm [.030"] thick, 2 oz. copper, $\epsilon_r = 3.66$
Find Gerber files for this test fixture on the Wolfspeed Web site at www.wolfspeed.com/RF	

Reference Circuit (cont.)

Reference Circuit Assembly

Electrical Characteristics at 1880 MHz

Transmission Line	Electrical Characteristics	Dimensions: mm	Dimensions: mils
Input			
TL101	0.029 λ , 28.26 Ω	W = 3.81, L = 2.67	W = 150, L = 105
TL102, TL103, TL105, TL159, TL162, TL163	0.014 λ , 28.26 Ω	W1 = 3.81, W2 = 3.81, W3 = 1.27	W1 = 150, W2 = 150, W3 = 50
TL104	0.020 λ , 28.26 Ω	W = 3.81, L = 1.83	W = 150, L = 72
TL106	0.032 λ , 51.05 Ω	W = 1.63, L = 3.05	W = 64, L = 120
TL107	0.091 λ , 51.05 Ω	W = 1.63, L = 8.64	W = 64, L = 240
TL109	0.022 λ , 76.77 Ω	W = 0.76, L = 2.16	W = 30, L = 85
TL110, TL130	0.026 λ , 76.77 Ω	W = 0.76, L = 2.54	W = 30, L = 100
TL111	0.012 λ , 12.71 Ω	W = 10.03, L = 1.02	W = 395, L = 40
TL112	0.009 λ , 12.71 Ω	W1 = 10.03, W2 = 10.03, W3 = 0.76	W1 = 395, W2 = 395, W3 = 30
TL114	0.014 λ , 23.02 Ω	W = 4.95, L = 1.27	W = 195, L = 50
TL115	0.098 λ , 12.71 Ω	W = 10.03, L = 8.59	W = 395, L = 338
TL117, TL146	0.013 λ , 51.05 Ω	W = 1.63, L = 1.27	W = 64, L = 50
TL120	0.066 λ , 51.05 Ω	W = 1.63, L = 6.27	W = 64, L = 247
TL121	0.038 λ , 51.05 Ω	W = 1.63, L = 3.56	W = 64, L = 140
TL122	0.060 λ , 51.05 Ω	W = 1.63, L = 5.69	W = 64, L = 224
TL123	0.009 λ , 11.33 Ω	W1 = 11.43, W2 = 11.43, W3 = 0.76	W1 = 450, W2 = 450, W3 = 30
TL126	0.144 λ , 76.77 Ω	W = 0.76, L = 1.14	W = 30, L = 551
TL127	0.037 λ , 51.05 Ω	W = 1.63, L = 3.45	W = 64, L = 136
TL128	0.013 λ , 51.05 Ω	W = 1.63, L = 1.19	W = 64, L = 47
TL129	0.055 λ , 76.77 Ω	W = 0.76, L = 5.38	W = 30, L = 212
TL131	0.012 λ , 11.33 Ω	W = 11.43, L = 1.02	W = 450, L = 40
TL132	0.055 λ , 38.04 Ω	W = 2.54, L = 5.08	W = 100, L = 200
TL133	0.102 λ , 11.33 Ω	W = 11.43, L = 8.89	W = 450, L = 350
TL134	0.031 λ , 76.77 Ω	W = 0.76, L = 2.97	W = 30, L = 117
TL135	0.040 λ , 51.05 Ω	W = 1.63, L = 3.81	W = 64, L = 149
TL137	0.023 λ , 51.05 Ω	W = 1.63, L = 2.16	W = 64, L = 85
TL139	0.043 λ , 51.05 Ω	W = 1.63, L = 4.06	W = 64, L = 160
TL141	0.118 λ , 51.05 Ω	W = 1.63, L = 11.18	W = 64, L = 440
TL142, TL143, TL 154, TL164	0.013 λ , 76.77 Ω	W1 = 0.76, W2 = 0.76, W3 = 1.27	W1 = 30, W2 = 30, W3 = 50
TL144	0.010 λ , 76.77 Ω	W = 0.76, L = 0.97	W = 30, L = 38

table continued on next page



Reference Circuit (cont.)

Electrical Characteristics at 1880 MHz

Transmission Line	Electrical Characteristics	Dimensions: mm	Dimensions: mils
Input (cont.)			
TL149	0.078 λ , 28.26 Ω	W = 3.81, L = 7.09	W = 150, L = 279
TL152	0.009 λ , 28.26 Ω	W = 3.81, L = 0.81	W = 150, L = 32
TL153	0.192 λ , 76.77 Ω	W = 0.76, L = 18.62	W = 30, L = 733
TL156	0.054 λ , 76.77 Ω	W = 0.76, L = 5.23	W = 30, L = 206
TL157	0.024 λ , 76.77 Ω	W = 0.76, L = 2.31	W = 30, L = 91
TL158, TL165	0.042 λ , 28.26 Ω	W = 3.81, L = 3.81	W = 150, L = 150
TL160	0.013 λ , 28.26 Ω	W = 3.81, L = 1.19	W = 150, L = 47
TL161	0.025 λ , 28.26 Ω	W = 3.81, L = 2.31	W = 150, L = 91
Output			
TL201, TL267	0.014 λ , 28.26 Ω	W1 = 3.81, W2 = 3.81, W3 = 1.27	W1 = 150, W2 = 150, W3 = 50
TL202, TL251, TL262	0.014 λ , 42.19 Ω	W1 = 2.18, W2 = 2.18, W3 = 1.27	W1 = 86, W2 = 86, W3 = 50
TL203, TL265	0.099 λ , 28.26 Ω	W = 3.81, L = 9.04	W = 150, L = 356
TL204	0.002 λ , 11.04 Ω	W = 11.76, L = 0.13	W = 463, L = 5
TL205	0.015 λ , 42.19 Ω	W = 2.18, L = 1.42	W = 86, L = 56
TL206	0.109 λ , 42.19 Ω	W = 2.18, L = 10.16	W = 86, L = 400
TL208	0.123 λ , 11.04 Ω	W = 11.76, L = 10.72	W = 463, L = 422
TL209	0.120 λ , 8.6 Ω	W = 15.52, L = 10.39	W = 611, L = 409
TL210	0.017 λ , 25.19 Ω	W = 4.42, L = 1.52	W = 174, L = 60
TL211, L260	0.057 λ , 25.19 Ω	W = 4.42, L = 5.13	W = 174, L = 202
TL214	0.005 λ , 25.19 Ω	W = 4.42, L = 0.48	W = 174, L = 17
TL216	0.083 λ , 31.13 Ω	W = 3.35, L = 7.62	W = 132, L = 300
TL217	0.048 λ , 31.13 Ω	W1 = 3.35, W2 = 3.35, W3 = 4.42	W1 = 132, W2 = 132, W3 = 174
TL218	0.025 λ , 11.04 Ω	W1 = 11.76, W2 = 11.76, W3 = 2.18	W1 = 463, W2 = 463, W3 = 86
TL220	0.184 λ , 25.19 Ω	W = 4.42, L = 16.71	W = 174, L = 658
TL221	0.084 λ , 32.41 Ω	W = 3.18, L = 7.77	W = 125, L = 306
TL222, TL239	0.027 λ , 47.41 Ω	W = 1.83, L = 2.54	W = 72, L = 100
TL223, TL224	0.034 λ , 47.41 Ω	W = 1.83, L = 3.18	W = 72, L = 125
TL225, TL242	0.014 λ , 47.41 Ω	W = 1.83, L = 1.27	W = 72, L = 50
TL230	0.032 λ , 51.05 Ω	W = 1.63, L = 3.05	W = 64, L = 120
TL231	0.016 λ , 51.05 Ω	W = 1.63, L = 1.5	W = 64, L = 59

table continued on next page

Reference Circuit (cont.)

Electrical Characteristics at 1880 MHz			
Transmission Line	Electrical Characteristics	Dimensions: mm	Dimensions: mils
Output (cont.)			
TL234	0.011 λ , 8.6 Ω	W1 = 15.52, W2 = 15.52, W3 = 0.91	W1 = 611, W2 = 611, W3 = 36
TL237	0.051 λ , 70.38 Ω	W = 0.91, L = 4.93	W = 36, L = 194
TL238	0.079 λ , 70.38 Ω	W = 0.91, L = 7.62	W = 36, L = 300
TL240	0.049 λ , 89.14 Ω	W = 0.53, L = 4.78	W = 21, L = 188
TL241	0.002 λ , 8.6 Ω	W = 15.52, L = 0.13	W = 611, L = 5
TL245	0.156 λ , 28.26 Ω	W = 3.81, L = 14.27	W = 150, L = 562
TL246, TL263, TL268	0.013 λ , 70.38 Ω	W1 = 0.91, W2 = 0.91, W3 = 1.27	W1 = 36, W2 = 36, W3 = 50
TL247	0.127 λ , 70.38 Ω	W = 0.91, L = 12.24	W = 36, L = 482
TL250	0.198 λ , 28.26 Ω	W = 3.81, L = 18.11	W = 150, L = 713
TL253	0.038 λ , 42.19 Ω	W = 2.18, L = 3.58	W = 86, L = 141
TL254	0.0003 λ , 31.13 Ω	W = 3.35, L = 0.03	W = 132, L = 1
TL256	0.028 λ , 31.13 Ω	W = 3.35, L = 2.54	W = 132, L = 100
TL257	0.062 λ , 31.13 Ω	W = 3.35, L = 5.69	W = 132, L = 224
TL264	0.021 λ , 70.38 Ω	W = 0.91, L = 2.03	W = 36, L = 80
TL266	0.015 λ , 70.38 Ω	W = 0.91, L = 1.42	W = 36, L = 56
TL269	0.086 λ , 42.19 Ω	W = 2.18, L = 8	W = 86, L = 315
TL270	0.027 λ , 42.19 Ω	W = 2.18, L = 2.51	W = 86, L = 99

discontinued product

Reference Circuit (cont.)

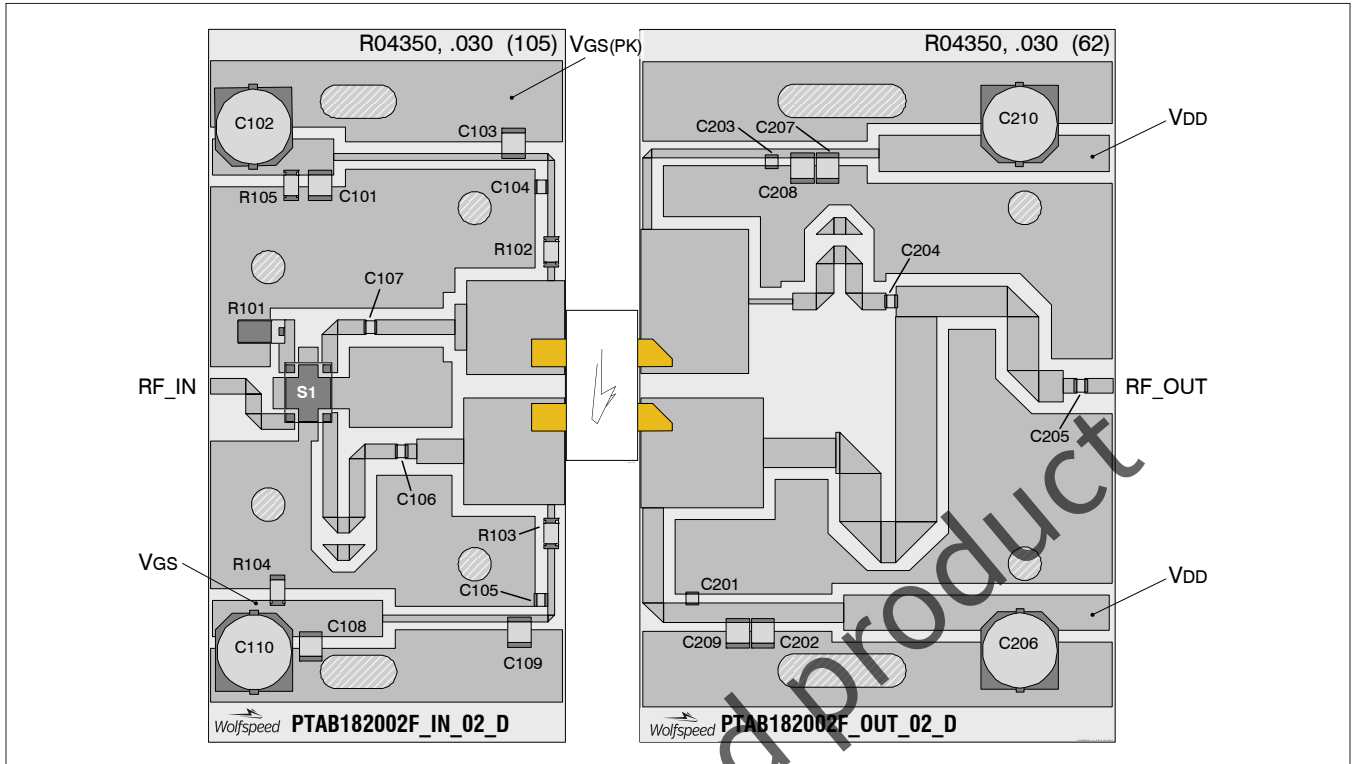

Reference circuit assembly diagram (not to scale)

Components Information

Component	Description	Suggested Supplier	P/N
Input			
C101, C108	Chip capacitor, 0.1 μ F	Kemet	C120C104K5RACTU
C102, C110	Capacitor, 100 μ F	Panasonic	EEE-FP1V101AP
C103, C109	Capacitor, 10 μ F	Taiyo Yuden	UMK325C7106MM-T
C104, C105, C106, C107	Chip capacitor, 24 pF	ATC	ATC100A240JW150XB
R101	Resistor, 50 Ω	Anaren	C16A5024
R102, R103	Resistor, 10 Ω	Panasonic	ERJ-8GEYJ100V
R104, R105	Resistor, 1000 Ω	Panasonic	ERJ-8GEYJ102V
U1 / S1	90° RF directional coupler	Anaren	X3C19P1-05S
Output			
C201, C203, C204, C205	Chip capacitor, 24 pF	ATC	ATC100A240JW150XB
C202, C207, C208, C209	Capacitor, 10 μ F	Taiyo Yuden	UMK325C7106MM-T
C206, C210	Capacitor, 220 μ F	Panasonic	EEEF1V221AP

Pinout Diagram (top view)

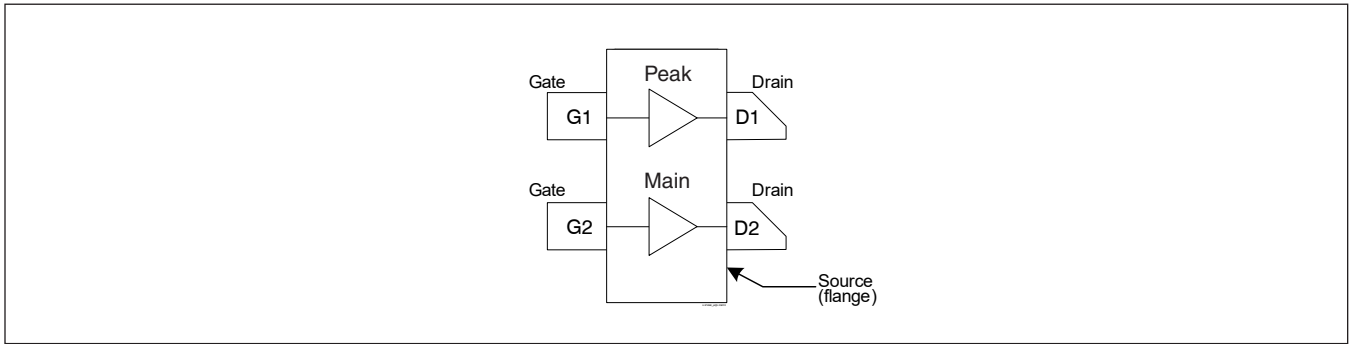

Lead connections for PTAB182002FC

See next page for Package Outline Specifications

discontinued product

Package Outline Specifications

