

## 1. General description

---

PTN5110 is a single-port TCPC compliant USB Power Delivery (PD) PHY IC that implements Type-C Configuration Channel (CC) interface and USB PD Physical layer functions to a Type-C Port Manager (TCPM) that handles PD Policy management. It is designed to comply with USB PD [1], Type-C [2] and TCPC [3] specifications. This IC is targeted primarily for use in system platforms (e.g. Notebook PCs, Desktop PCs, Chromebooks, Tablets, Convertibles, etc.). Other use cases may be feasible depending on the application architecture, e.g. docks, monitors, accessories, cable adapters, smartphones etc.

It can support various Type-C roles: Sink, Source, Sink with accessory support or DRP. It implements Type-C CC analog portion (i.e Rd/Rp/Ra detection, Rd/Rp indication) and PD Tx/Rx PHY and protocol state machines as per [3]. PTN5110 supports TCPM in system realization of the following PD roles:

1. Provider (P)
2. Provider/Consumer (P/C)
3. Consumer (C)
4. Consumer/Provider (C/P)

PTN5110 integrates VCONN load switch with programmable current limit, reverse leakage current blocking and Over Temperature Protection (OTP). It implements two enable control outputs for controlling load switches/FETs on VBUS source and/or sink power paths. It also implements VBUS voltage monitoring/measurement, VBUS Force discharge and Bleed discharge features as defined in [3]. PTN5110 implements I<sup>2</sup>C-bus interface registers, finite state machines and control flow, etc. as defined in [3]. Please refer to [3] for description of I<sup>2</sup>C registers, control descriptions, flow diagrams, etc.

PTN5110 provides the majority of relevant IO capability for the host processor/TCPM to easily control and manage the Type-C/PD interface via the TCPC interface:

- VBUS Power path control of source and sink power rails (EN\_SRC, EN\_SNK1)
- Up to four different slave addresses can be selected based on SLV\_ADDR
- ILIM\_5V\_VBUS that allows TCPM to set two different current limits on VBUS 5 V Load switch.
- FRS\_EN that allows for arming 5 V SRC load switch for Fast Role Swap (FRS) support
- DBG\_ACC that can be used by host TCPM indicate Type-C debug accessory detection

PTN5110 offers tremendous flexibility to platform integrators by supporting a wide range of power supply input voltages.



PTN5110 is available in HX2QFN16, 2.6 mm x 2.6 mm x 0.35 mm, 0.4 mm pitch.

**Remark:**

1. PTN5110 provides independently controllable pull-up resistor (Rp) implementations on CC1 and CC2 pins.
2. PTN5110 can detect/monitor voltage levels independently on each CC pin.

## 2. Features and benefits

### 2.1 USB PD and Type-C features

- Designed to comply with USB PD[1], USB Type-C [2] and TCPC [3] specifications
- Supports Type-C functionality as per [2][3]
  - ◆ Provides CC analog functions: Rp and Rd/GND dynamic indication and Rp/Rd/Ra dynamic detection, debouncing of CC pins, dynamic selection of different Rp/Rd values for CC1 and CC2 independently
  - ◆ Implements SNK role pull-down (Rd) behavior to handle dead battery/no power condition
  - ◆ Support for Type-C Debug Accessory detection and orientation detection (refer to Appendix of [2]) for Source and Sink Target Systems (TS). Indication of the result via dedicated pin (DBG\_ACC) and status registers.
  - ◆ Plug orientation detection and indication via status register(s)
  - ◆ Supports integrated VCONN switch(es) delivering power to accessory
- Cooperatively work under TCPM control for Type-C Connection/Disconnection Detection, Power Delivery negotiation and contract(s), Alternate mode support, VDM exchanges and any custom functions
  - ◆ Implements TCPC functionality as per [3]
  - ◆ SOP\* Configurable: Register programmable to generate and receive SOP, SOP', SOP'-debug, SOP'', SOP''-debug"
  - ◆ Supports Extended messaging Unchunked and Chunked based packet transport
  - ◆ VBUS Bleed and Force discharge schemes are implemented as per [3]
  - ◆ Implements VCONN discharge on Hard Reset (TCPM Controlled)
  - ◆ Implements Fast Role Swap request detection (in 'initial sink' role) and indication (in 'initial source' role)
  - ◆ Supports VBUS source/sink power path control
  - ◆ Supports Seamless VBUS source voltage transitions among PD voltage rails (e.g. using Load switches - 5 V VBUS source switch - NX5P3290, High Voltage VBUS source switch):
    - For positive voltage transitions, PTN5110 implements make-before-break feature (turn on higher voltage rail first and turn off lower voltage rail after a programmable time duration determined by summation of turn-on time and enable time of higher voltage rail load switch).
    - For negative voltage transitions, PTN5110 disables higher voltage rail load switch initially, performs force discharge and monitors VBUS voltage until stop threshold is reached and enables lower voltage rail load switch when VBUS voltage reaches equal to (or slightly less than) the programmed rail voltage in the TCPC I<sup>2</sup>C VBUS voltage Alarm register.

- ◆ For a multi-port system implementation, PTN5110 allows for
  - TCPM initiated VBUS Sink path transitions from one Type-C port to another Type-C port using NXP High voltage sink switch (NX20P5090)
  - Single VBUS Sink power path enabling under dead battery (when multiple Type-C ports can provide VBUS 5 V power)

## 2.2 System protection features

- Back current protection on all pins when PTN5110 is unpowered
- CC pins are 6 V tolerant

## 2.3 General

- Provides two Power path enable controls: EN\_SRC, EN\_SNK1
- TCPM Host interface control and status update handled via I<sup>2</sup>C-bus interface. Supports I<sup>2</sup>C slave interface standard mode (100 kHz), Fast mode (400 kHz) and Fast mode plus (1 MHz)
- Up to four I<sup>2</sup>C device slave address options selectable via SLV\_ADDR pin. This allows for multi-port implementation with PTN5110
- Supports register access: device configuration, control and status/interrupt interfacing through Slave I<sup>2</sup>C-bus conforming to [3]
- Power supply: VDD range (2.7 V to 5.5 V) and VBUS (4 V to 25 V)
  - ◆ Tolerant up to 28 V on VBUS (and operational up to maximum of 25 V on VBUS)
- Ambient operating temperature range –40 to 85 °C
- ESD 8 kV HBM, 1 kV CDM
- Package: HX2QFN16, 2.6 mm x 2.6 mm x 0.35 mm, 0.4 mm pitch

### 3. Applications

---

- PC platforms: Notebook PCs, Desktop PCs, Ultrabooks, Chromebooks
- Tablets, 2:1 Convertibles, Smartphones and Portable devices
- PC accessories/peripherals: Docking, Mobile Monitors, Multi-Function Monitors, Portable/External hard drives, Cable adaptors, Dongles and accessories, etc.

## 4. Ordering information

**Table 1. Ordering information**

Type number	Topside mark	Package		
		Name	Description	Version
PTN5110HQ <sup>[1]</sup>	511	HX2QFN16	plastic, thermal enhanced super thin quad flat package; no leads; 16 terminals; body 2.6 x 2.6 x 0.35 mm	SOT1883-1
PTN5110DHQ <sup>[1]</sup>	51D	HX2QFN16	plastic, thermal enhanced super thin quad flat package; no leads; 16 terminals; body 2.6 x 2.6 x 0.35 mm	SOT1883-1
PTN5110THQ <sup>[1]</sup>	51T	HX2QFN16	plastic, thermal enhanced super thin quad flat package; no leads; 16 terminals; body 2.6 x 2.6 x 0.35 mm	SOT1883-1
PTN5110NHQ <sup>[1]</sup>	51N	HX2QFN16	plastic, thermal enhanced super thin quad flat package; no leads; 16 terminals; body 2.6 x 2.6 x 0.35 mm	SOT1883-1
PTN5110NTHQ <sup>[1]</sup>	5NT	HX2QFN16	plastic, thermal enhanced super thin quad flat package; no leads; 16 terminals; body 2.6 x 2.6 x 0.35 mm	SOT1883-1
PTN5110NDHQ <sup>[1]</sup>	5ND	HX2QFN16	plastic, thermal enhanced super thin quad flat package; no leads; 16 terminals; body 2.6 x 2.6 x 0.35 mm	SOT1883-1

[1] Total height after printed-circuit board mounting ≤0.5 mm (maximum)

### 4.1 Ordering options

**Table 2. Ordering options and their specific characteristics**

Ordering option	Description
PTN5110HQ	<p>This ordering option supports TCPC Rev 1.0 version 1.1. This ordering option is configured for DRP at POR.</p> <p>The DRP toggle starting state is set for Sink (Rd) role.</p> <p>It supports detection of debug (Rd,Rd) and audio (Ra, Ra) accessories.</p> <p>The FET enable outputs EN_SNK and EN_SRC are meant for sink and source power path controls respectively.</p>
PTN5110DHQ	<p>This ordering option supports TCPC Rev 1.0 version 1.1. This ordering option is configured for UFP/Sink role at POR.</p> <p>The CC1/2 pins present sink (Rd) role.</p> <p>The FET enable outputs EN_SNK and EN_SRC are meant for sink and source power path controls respectively.</p>
PTN5110THQ	<p>This ordering option supports TCPC Rev 1.0 version 1.1. This ordering option is configured for DFP/Source role at POR.</p> <p>This supports detection of debug (Rd,Rd) and audio (Ra, Ra) accessories.</p> <p>The FET controls EN_SRC controls 5V VBUS source path and EN_SNK is meant to be used for controlling higher voltage VBUS output.</p> <p>PTN5110 provides 'Make before Break' capability while transitioning from 5V to higher voltage and vice versa when used along with NXP load switches (NX5P3290 and NX20P5090).</p>

**Table 2. Ordering options and their specific characteristics ...continued**

Ordering option	Description
PTN5110NHQ	This ordering option supports TCPC Rev 2.0 version 1.0. This ordering option is configured for DRP at POR. The DRP toggle starting state is set for Sink (Rd) role. It supports detection of debug (Rd,Rd) and audio (Ra, Ra) accessories. The FET enable outputs EN_SNK and EN_SRC are meant for sink and source power path controls respectively.
PTN5110NTHQ	This ordering option supports TCPC Rev 2.0 version 1.0. This ordering option is configured for DFP/Source role at POR. It supports detection of debug (Rd,Rd) and audio (Ra, Ra) accessories. The FET controls EN_SRC controls 5V VBUS source path and EN_SNK is meant to be used for controlling higher voltage VBUS output.
PTN5110NDHQ	This ordering option supports TCPC Rev 2.0 version 1.0. This ordering option is configured for UFP/Sink role at POR. The CC1/2 pins present sink (Rd) role. The FET enable outputs EN_SNK and EN_SRC are meant for sink and source power path controls respectively.

**Table 3. Ordering options**

Type number	Orderable part number	Package	Packing method	Minimum order quantity	Temperature
PTN5110HQ	PTN5110HQZ	HX2QFN16	REEL 7" Q2/T3 *STANDARD MARK SMD	4000	T <sub>amb</sub> = -40 °C to +85 °C
PTN5110DHQ	PTN5110DHQZ	HX2QFN16	REEL 7" Q2/T3 *STANDARD MARK SMD	4000	T <sub>amb</sub> = -40 °C to +85 °C
PTN5110THQ	PTN5110THQZ	HX2QFN16	REEL 7" Q2/T3 *STANDARD MARK SMD	4000	T <sub>amb</sub> = -40 °C to +85 °C
PTN5110NHQ	PTN5110NHQZ	HX2QFN16	REEL 7" Q2/T3 *STANDARD MARK SMD	4000	T <sub>amb</sub> = -40 °C to +85 °C
PTN5110NDHQ	PTN5110NDHQZ	HX2QFN16	REEL 7" Q2/T3 *STANDARD MARK SMD	4000	T <sub>amb</sub> = -40 °C to +85 °C
PTN5110NTHQ	PTN5110NTHQZ	HX2QFN16	REEL 7" Q2/T3 *STANDARD MARK SMD	4000	T <sub>amb</sub> = -40 °C to +85 °C

**5. Block diagram**

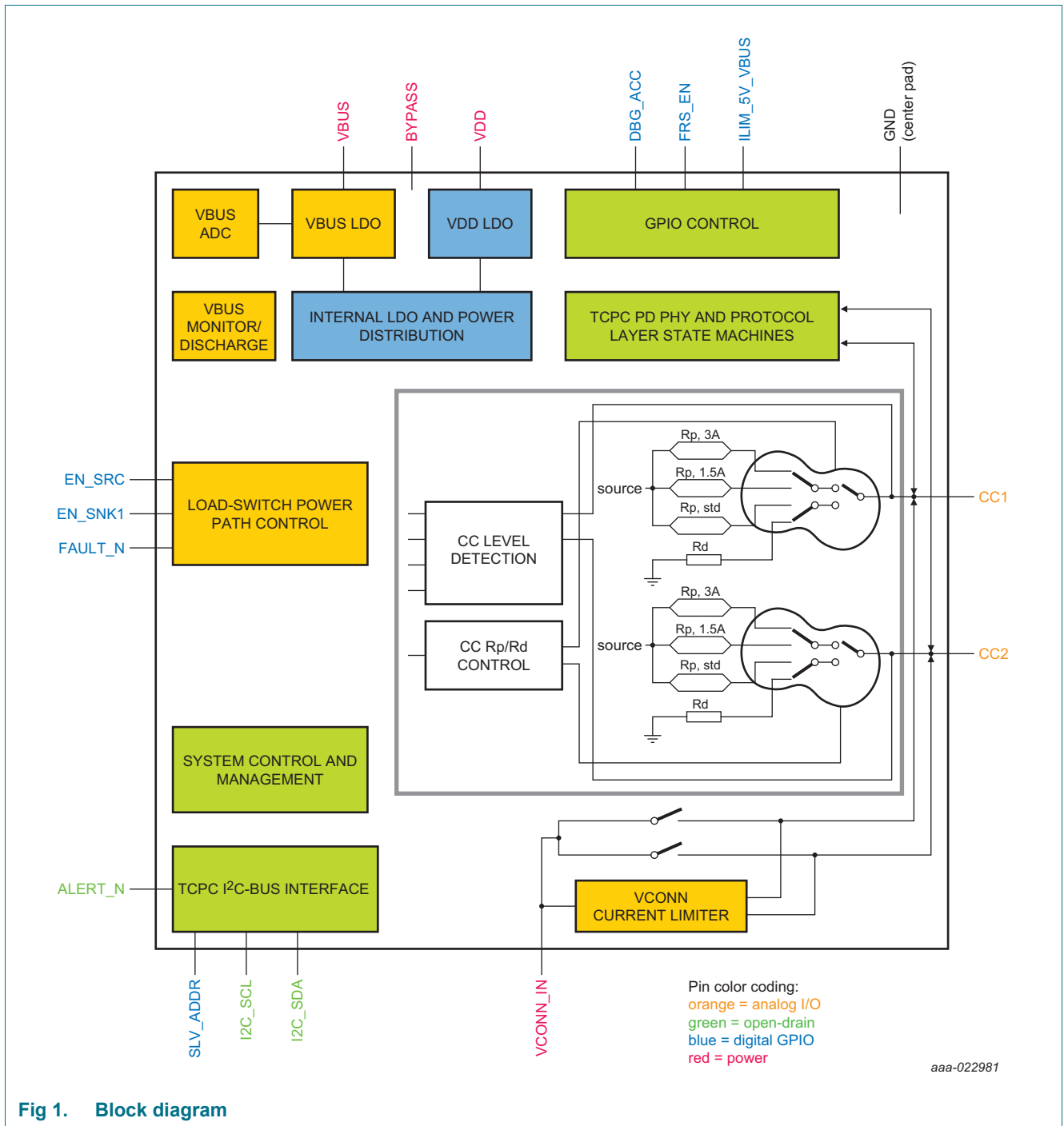

**Fig 1. Block diagram**

## 6. Pinning information

### 6.1 Pinning

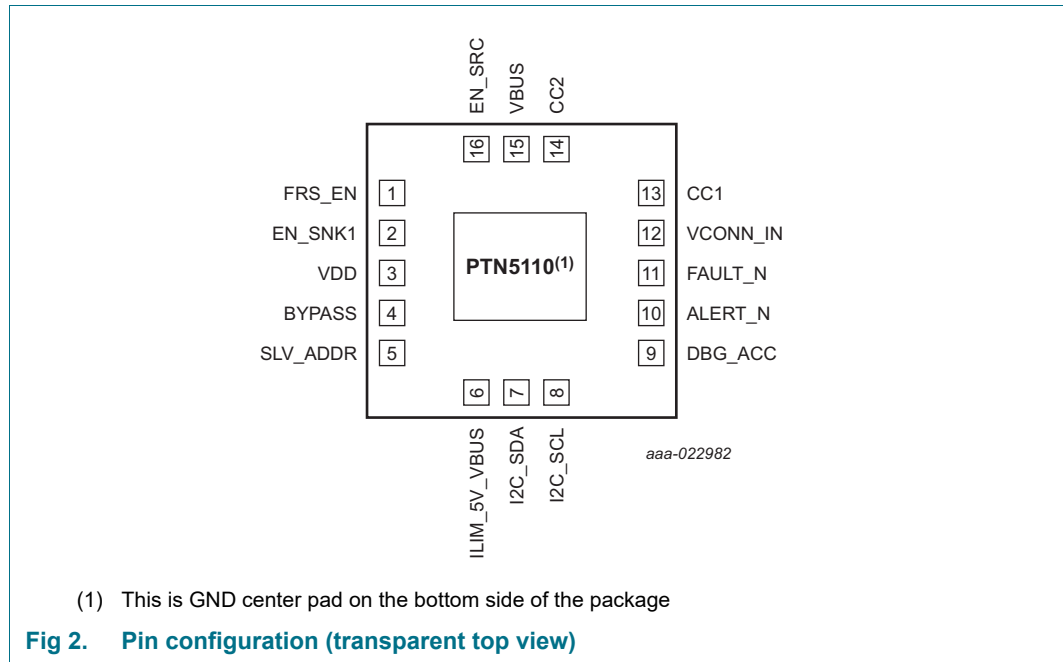

### 6.2 Pin description

**Table 4. Pin description**

Symbol	Pin	Pin direction	Pin type	Description
FRS_EN	1	Output	CMOS IO (referenced to BYPASS pin)	This pin is used by TCPM for FRS enable control of a 5 V SRC Load switch (e.g. FO pin of NX5P3290). Default value is LOW. This can also be used for other GPIO purposes.
EN_SNK1	2	Output	CMOS IO (referenced to BYPASS pin)	VBUS Sink Power path control output. At default/POR, this pin is LOW. This pin is controllable via TCPC interface. This can also be used for VBUS source power path control in PD source only applications
VDD	3	Power Input	Power	Core domain power supply; (2.7 V to 5.5 V) External supply decoupling capacitor(s) (2.2 $\mu$ F +/-10 %) are required
BYPASS	4	Internal	Internal power rail	Internal node An external capacitor (e.g. 2.2 $\mu$ F +/-20 %) is required to be connected to this pin
SLV_ADDR	5	IO	Quaternary Input	I <sup>2</sup> C slave address selection pin. This pin is wired to BYPASS pin (in the PCB) for two of the four SLV_ADDR options. This pin is sampled at POR only.



Table 4. Pin description ...continued

Symbol	Pin	Pin direction	Pin type	Description
ILIM_5V_VBUS	6	IO	CMOS IO (referenced to BYPASS pin)	This GPIO pin is used by TCPM to select current limit (default current versus 1.5 A/3 A) setting of 5 V VBUS SRC load switch. Default value is LOW. This can also be used for other GPIO purposes.
I2C_SDA	7	IO	Open drain IO	I <sup>2</sup> C data This pin needs to be externally pulled up to VDD
I2C_SCL	8	Input	Open drain IO	I <sup>2</sup> C clock This pin needs to be externally pulled up to VDD
DBG_ACC	9	Output	CMOS IO (referenced to BYPASS pin)	Indicates the presence of Type-C Debug accessory. Default/POR is HIGH. If debug accessory is present and if Debug Accessory Control bit of TCPC_CONTROL register is 0, PTN5110 asserts this pin LOW. This can also be used for other GPIO purposes.
ALERT_N	10	Output	Open drain IO	Level triggered open drain interrupt output This pin needs to be externally pulled up by 10 kΩ to VDD
FAULT_N	11	Input	Open drain	This input is open drain fault indication signal from load switches (e.g. NX5P3290, NX20P5090). If the pin is LOW, then PTN5110 updates the fault status register and also can raise the host interrupt, if enabled. The fault status register bit reflects the pin status automatically.  This pin has to be pulled up externally to 10 kΩ and when this pin is LOW, it indicates a FAULT condition on either Source or sink power path
VCONN_IN	12	Power Input	Power	VCONN power input. An external capacitor (e.g. 2.2 μF +/-10 % or different value) can be connected to this pin
CC1	13	IO	Custom IO	Type-C Configuration channel #1 Protection diode (e.g. PESD5V0S1USF/BSF, PESD5V0S1UL/BL, etc) shall be used to protect the pin from overshoot/ undershoot during cable plug/ unplug and cable discharge events
CC2	14	IO	Custom IO	Type-C Configuration channel #2 Protection diode (e.g. PESD5V0S1USF/BSF, PESD5V0S1UL/BL, etc) shall be used to protect the pin from overshoot/ undershoot during cable plug/ unplug and cable discharge events.
VBUS	15	Power Input	Power	VBUS power supply; External supply decoupling capacitor(s) (2.2 μF +/-10 %) are required
EN_SRC	16	Output	CMOS IO (referenced to BYPASS pin)	5 V VBUS Source Power path control At default/POR, this pin is LOW; this pin is controllable via TCPC interface
GND				Center pad as Ground

## 7. Functional description

PTN5110 is a TCPC compliant USB Type-C PD PHY IC that can be used to realize single or multi-port USB Type-C PD and/or Alternate mode implementations. It is designed to comply with USB PD [1], Type-C [2] and TCPC [3] specifications.

PTN5110 can be partitioned into the following major functional blocks along with their respective interfaces:

- Type-C Configuration Channel function
- USB Power Delivery function
- VCONN switch and control
- VBUS Power path Control
- TCPC I<sup>2</sup>C-bus interface and Control
- Power management
- Power supply

The following subsections describe the PTN5110 with its major functional blocks.

### 7.1 Type-C Configuration Channel functional block

Type-C Configuration Channel (CC) function operates as a front end to cable/plug interface. This block implements Orientation detection (TCPM detects orientation and informs TCPC of the result), Cable/Plug insertion (only initial indication, TCPM verifies connection and tells TCPC when the connection is valid) and removal detection under different roles (SRC, DRP, SNK including accessory support) as per [2][3].

In particular, PTN5110 supports Type-C functionality

- Applying 'Rp (for CC1)', 'Rp (for CC2)', or 'Rd' depending on the configured role
- Detecting cable/plug connect and disconnect events
- Indicating Type-C current limit level in a system under Source role
- Detecting the current level supported by remote end under Sink role
- Supports TCPM in identifying plug orientation and indicating through TCPCi register interface
- Implements VBUS thresholds, monitoring and measurement
- Discharging VBUS and VCONN based on Type-C status/PD Policy (managed by TCPM)
- Supports TCPM in identifying Type-C Debug accessory detection and indicating through TCPCi register interface and DBG\_ACC pin. TCPM implements Type-C Debug scheme
- Supports TCPM in Audio accessory detection and indication via status register
- Updating event, interrupt and status registers using ALERT\_N pin
- Try.SRC/ Try.SNK feature can be enabled (this is supported only in the ordering option - PTN5110HQ, PTN5110DHQ, PTN5110THQ)

## 7.2 USB power delivery function

TCPM handles the PD policy management and interfacing to Application/Platform power management given the system states, battery status, etc. It reviews capabilities and status of various power providers (USB PD, AC-DC adapter, battery, docking, etc.) dynamically and determines a specific source for powering/charging the platform; the power source selection is an important and platform dependent aspect of Application power delivery scheme.

- For example, in some computing applications, EC (with integrated TCPM function) plays a central role in controlling the various power sources including USB PD. To support this, PTN5110 facilitates this by helping to send/receive USB PD messages. It implements PD PHY and Protocol functions as per [3].
- In several applications, EC may not even exist or EC wants to play a hands-off role. To support these applications, a dedicated TCPM can be utilized that works with PTN5110 to realize PD functionality.

In a Type-C PD implementation, the system partitioning involves the following parts:

- Port PHY function → PTN5110 (TCPC PHY implemented as per [3])
- Port policy engine and device policy management, Alternate mode support → TCPM (this may be integrated with EC or SMC)

The interface bus between PTN5110 and TCPM is I<sup>2</sup>C [4]. PTN5110 provides a transparent set of commands and register interface to control the operation and ensure robust system behavior. PTN5110 Application Programming guide [5] describes the register set supported for the PD control, status updates and operational control/sequences. PTN5110 provides a USB PD TCPC Interface compliant register map as well as additional vendor defined features.

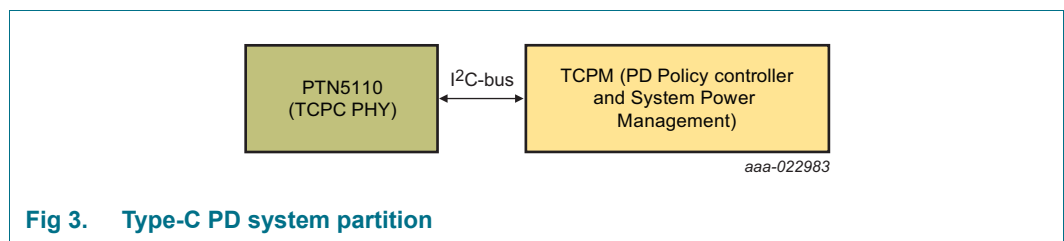

**Fig 3. Type-C PD system partition**

PTN5110 implements USB PD PHY layer function as follows.

- CC Analog IO complying to TX/RX masks
- Bit transmission and reception
- Biphase mark coding
- 4B5B line coding
- CRC computation and checking
- FRS request detection (in initial PD sink role) and indication (in initial PD source role). The FRS\_EN pin is used to 'arm' the 5 V VBUS Source load switch during FRS operation. PTN5110 can detect the FRS request signaling and autonomously switch over to Source role (if previously, in Sink role)

It also handles PD Protocol layer functions (TX and RX protocol state machines) as per [3].

To minimize chances of collision, PTN5110 checks the CC line before start of transmission. Once the data is transmitted or received, the I<sup>2</sup>C-bus interface status is updated and TCPM is interrupted. It also provides support for a bus management scheme as defined in [1].

BIST mode (Tx, Rx) is also supported.

### 7.3 VCONN switch and control

PTN5110 implements a very low RON switch that can deliver VCONN current; depending on the pin over which CC communication is established, VCONN\_IN power is delivered into the other CC pin. With its patented architecture, the switch implements Soft Start behavior to avoid heavy inrush current flow when it is enabled. The VCONN switch and protection circuitry can be activated only when VCONN\_IN is above VCONN present threshold. When in disabled condition, PTN5110 presents Hi-Z condition on the corresponding CCx pin.

The switch implements four important features relevant to application robustness

- Reverse Voltage Protection (RVP)
- Over Current Limiting (OCL)
- Over Temperature Protection (OTP)
- Short to GND protection

The fault conditions are mapped to VCONN fault status and interrupt bits in TCPC registers. There is an extended set of VCONN registers for configuring the deglitch duration, reattempt count re-assert delay, interrupt mask, fault status, etc. The TCPM can program these registers during TCPC initialization to achieve desired behavior. [5] provides more details on the registers and bit definitions.

#### 7.3.1 Reverse Voltage Protection (RVP)

PTN5110 implements RVP that monitors for a certain voltage difference (over the deglitch duration) to disable the switch path and protect the system from reverse current flow. After the 'reassert delay' is elapsed, PTN5110 enables the switch again. If the condition persists for 'reattempt count', then RVP fault status is asserted and if the interrupt is not masked, it would raise ALERT\_N for the host TCPM to take corrective measures. The 'reassert delay' and 'reattempt count' are defined in [5].

TCPM can program the deglitch duration, reassert delay, reattempt count via extended registers [5] at TCPCi level. The reverse voltage protection circuit can only be triggered when it is enabled.

PTN5110 also provides reverse leakage current blocking when the switch is not enabled. Irrespective of VCONN\_IN pin voltage, the reverse leakage current ( $I_{RLCL}$ ) on CC1/2 pin is LOW.

#### 7.3.2 Over Current Limiting (OCL)

PTN5110 supports four OCL threshold programmable levels. The Over Current Limiting (OCL) circuitry keeps monitoring for current flow above the pre configured level and whenever the threshold is exceeded, the switch goes into current limiting mode. It is possible for the switch to go into Over Temperature condition due to heating and go into OTP temperature cycling.

### 7.3.3 Over Temperature Protection (OTP)

If the switch has been enabled and if the device temperature exceeds a preset threshold, the device goes into Over Temperature condition. The OTP circuit disables the switch and triggers the fault status and raise interrupt (if enabled). Once the temperature reduces down to 85°C and after OTP reassert delay duration [5], the switch is enabled automatically. The TCPM can trigger disabling of the switch, if required.

### 7.3.4 Short to GND protection

PTN5110 can protect the system from hard short to GND. Whenever the current delivered goes beyond the highest threshold and up to  $I_{short}$ , PTN5110 turns off the switch within a few microseconds, enables the switch limiting the current flow up to the pre-programmed OCL limit. PTN5110 records the fault status and generate interrupt (if enabled). The TCPM can trigger disabling of the switch, if required.

## 7.4 VBUS power path control

Based on PD negotiation and contract, TCPM enables/disables specific power path (source or sink load switches). PTN5110 provides two power path control IO pins. They are:

- EN\_SRC: This is meant for 5 V Source control
  - ILIM\_5V\_VBUS is provided to control current limiting at default current (0.9 A) versus 1.5/3 A
- EN\_SNK1: This is meant for sinking current from VBUS (or, it can be configured to source a second power rail in a two-rail source system)

**Table 5. Power path combination illustration**

Configuration (not limited to)	Load switch* Combination (e.g. NX5P3290, NX20P5090, Source side Load switch)
5 V Source, 5 V to 20 V Sink	Source Load switch w/OCL = NX5P3290 (EN_SRC) Sink Load switch w/RCP = NX20P5090 (EN_SNK1)
5 V Source, 5 V to 20 V Sink	Source Load switch w/OCL = NX5P3290 (EN_SRC) Back-to-back Sink FET control (EN_SNK1)
5 V Source >5 V Source (two separate rails)	Source Load switch w/OCL = NX5P3290 (EN_SRC) Source Load switch w/OCL = high voltage source side Load switch (EN_SNK1)
5 V Sink	Sink Load switch w/RCP = NX20P5090 (EN_SNK1)

**Remark:** Platform integrators may use MOSFETs (with additional control circuitry) instead of Load switches while using PTN5110 in their applications.

With the support of NXP (RCP capable) Type-C Load switches, PTN5110 supports

- FRS operation
- Positive and Negative voltage transitions (while in SRC mode with two power rails)
- In a multi-port platform with buck boost configuration and dead battery condition, EN\_SNK1 pin activates NX20P5090 allowing current flow into the system. It is possible that this could potentially lead to multiple ports allowing sink current at 5 V into the system. Once the system initializes, the TCPM can selectively charge from a port only.

- Live/normal battery condition: PTN5110 need not enable EN\_SNK1 output autonomously since  $VDD > 0$ . TCPM can selectively enable a power path only
- Transition seamlessly from one Type-C port to another Type-C port without interrupting the charging/power flow into the system
  - This assumes using Load switches (e.g. NX20P5090) on all sink power paths. The TCPM can perform make-before-break operation on the sink paths and PTN5110 with its OVP feature helps prevent steady reverse current flow back into the port if the internal rail voltage is higher than the port voltage.

**Remark:** The FAULT\_N input pin shall be used only along with EN\_SRC/EN\_SNK1 pin control. In applications where EN\_SRC or EN\_SNK1 is used to control power switch, the FAULT\_N input can be connected to fault status indication output of the power switch(es). If PTN5110 does not control VBUS power path, then this FAULT\_N pin shall be pulled HIGH.

## 7.5 Host interface and control

PTN5110 works along with TCPM to realize USB PD functionality and/or Alternate mode support. The TCPM can control and interface with PTN5110 through the I<sup>2</sup>C-bus interface.

PTN5110 provides up to four I<sup>2</sup>C slave address combinations based on quaternary pin (SLV\_ADDR) setting as per [Table 6](#) below.

**Table 6. I<sup>2</sup>C slave address**

SLV_ADDR pin	Device address (Write/read) 7:0
GND	1010000x
10 K pull-up to BYPASS pin	1010001x
Unconnected	1010010x
100 K pull-up to BYPASS pin	1010011x

PTN5110 implements slave I<sup>2</sup>C-bus interface, TCPC registers as per [\[3\]](#) and vendor defined registers. Please refer to [\[3\]](#) for more information.

A detailed description of the I<sup>2</sup>C-bus specification, with applications, is given in user manual UM10204, "I<sup>2</sup>C-bus specification and user manual" [\[4\]](#).

PTN5110 Application programming guide [\[5\]](#) describes the various registers with their bit definitions, POR values and the various functions. Also, example 'C' programs corresponding to various functions and operations are included therein. This guide can be used by the platform system architects to implement the EC firmware to control the operations of PTN5110.

[Table 7](#) describes the TCPC identification registers and their Read only values.

Table 7. TCPC ID registers

Group	Offset	Name	Type	Default value	Bit field	Description
Identification registers	00h	VENDOR_ID	Read only word	0x1FC9	15:0	Vendor ID A unique 16-bit unsigned integer. Assigned by the USB-IF to the vendor.
	02h	PRODUCT_ID	Read only word	0x5110	15:0	USB product ID A unique 16-bit unsigned integer. Assigned uniquely by the vendor to identify the TCPC.
	04h	DEVICE_ID	Read only word	0x0001	15:0	bcdDevice A unique 16-bit unsigned integer. Assigned by the vendor to identify the version of the TCPC.
	06h	USBTYPEC_REV	Read only word	0x0012	15:8	Reserved
					7:0	USB Type-C revision Version number assigned by USB-IF 0001 0001b: Type-C revision 1.1 0001 0010b: Type-C revision 1.2
	08h	USBPD_REV_VER	Read only word	0x3010	15:8	bcdUSBPD revision 0010 0000b: USBPD revision 2.0 0011 0000b: USBPD revision 3.0
					7:0	bcdUSBPD version 0001 0000b: USBPD version 1.0 0001 0001b: USBPD version 1.1 etc.
	0Ah	PD_INTERFACE_REV	Read only word	0x0010	15:8	bcd USB-PD Inter-Block specification revision 0001 0000: TCPC revision 1.0
					7:0	bcd USB-PD Inter-Block specification version 0001 0000: TCPC version 1.0 0001 0001: TCPC version 1.1 etc.



## 7.6 Power management and power supplies

PTN5110 is designed to operate under a wide range of VDD and VBUS supply voltages. It can seamlessly transition from VBUS to VDD and vice versa.

Under dead battery operation, PTN5110 applies voltage clamps to both CC pins so that the system may receive power as a Sink. To support platforms with buck-boost configuration, PTN5110 asserts EN\_SNK1 pin based on validity of VBUS voltage (facilitates 5 V VBUS sinking).

The following table highlights the power supplies and operating conditions for PTN5110.

**Table 8. Power supplies versus operating conditions**

Valid Power supply Input combination	Operational condition	Remarks
VDD	Operation under dead and normal battery conditions	PTN5110 is operational. But the host I <sup>2</sup> C-bus interface and open drain GPIOs can be accessed after open drain pull-up voltage (to VDD) is available only
VBUS, VDD	Normal powered condition (both battery based or non-battery based platforms)	PTN5110 and its interfaces are operational. But the host I <sup>2</sup> C-bus interface and open drain GPIOs can be accessed after open drain pull-up voltage (to VDD) is available only

The relevant pins associated with this block are:

- VDD
- BYPASS: This is an internal voltage node
- VBUS: This is a connector side pin

PTN5110 provides power management support to conserve power consumption in both Type-C unattached and attached conditions. It supports sleep and wake-up features as per [3].

## 8. Use case view

---

Given that USB Power Delivery could address the requirements of a wide set of markets and product segments, PTN5110 is designed to work over a range of product categories, platform applications, use cases and usage roles. With its configurability, it can serve the needs of both general and custom applications. Not limited to these but the following subsections illustrate a set of example use cases of PTN5110. However, note that these use case diagrams do not capture all the details of schematic reference designs. For instance, ESD/TVS protection diodes are not captured. Please contact NXP for more information in this regard.



- Source VBUS 5 V (if not under dead battery)
- Charge from VBUS PD and AC barrel power, if applicable
- Source VCONN power

The EC communicates with PTN5110 via an I<sup>2</sup>C-bus interface and controls the operations.

An important aspect to note here is that PTN5110 would indicate a 'Rd' pull-down (Sink) under dead battery condition and this enables the port partner to provide VBUS @ 5 V (provided the port partner is capable of acting as Source). However, after system starts up, role swap may be performed to become Source and/or DFP. This is handled by PTN5110 and TCCP together.

DBG\_ACC, ILIM\_5V\_VBUS and FRS\_EN pins can be used by the platform, as necessary.

For this application context, it is recommended to use PTN5110HQ version of the IC. There is a consideration for making this recommendation here - buck boost charger power path is assumed to take longer time than that of PTN5110 VBUS debounce time of 15 ms.

If the VDD becomes available before VBUS debounce time of PTN5110, it is suggested to use PTN5110DHQ version.

**8.1.2 USB PD DRP (Provider/Consumer): Notebook PC with regular NVDC charger**

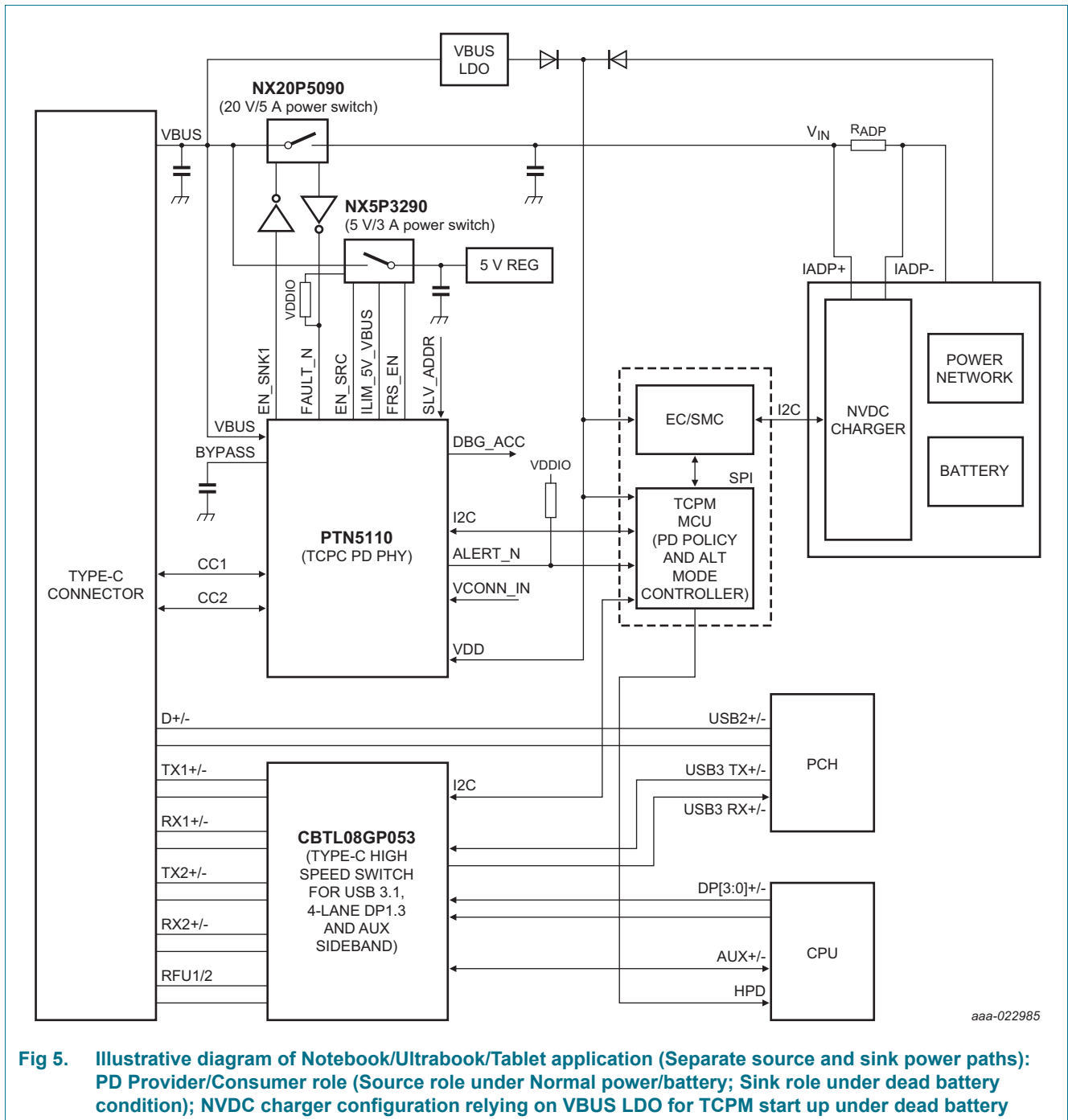

**Fig 5. Illustrative diagram of Notebook/Ultrabook/Tablet application (Separate source and sink power paths): PD Provider/Consumer role (Source role under Normal power/battery; Sink role under dead battery condition); NVDC charger configuration relying on VBUS LDO for TCPM start up under dead battery**

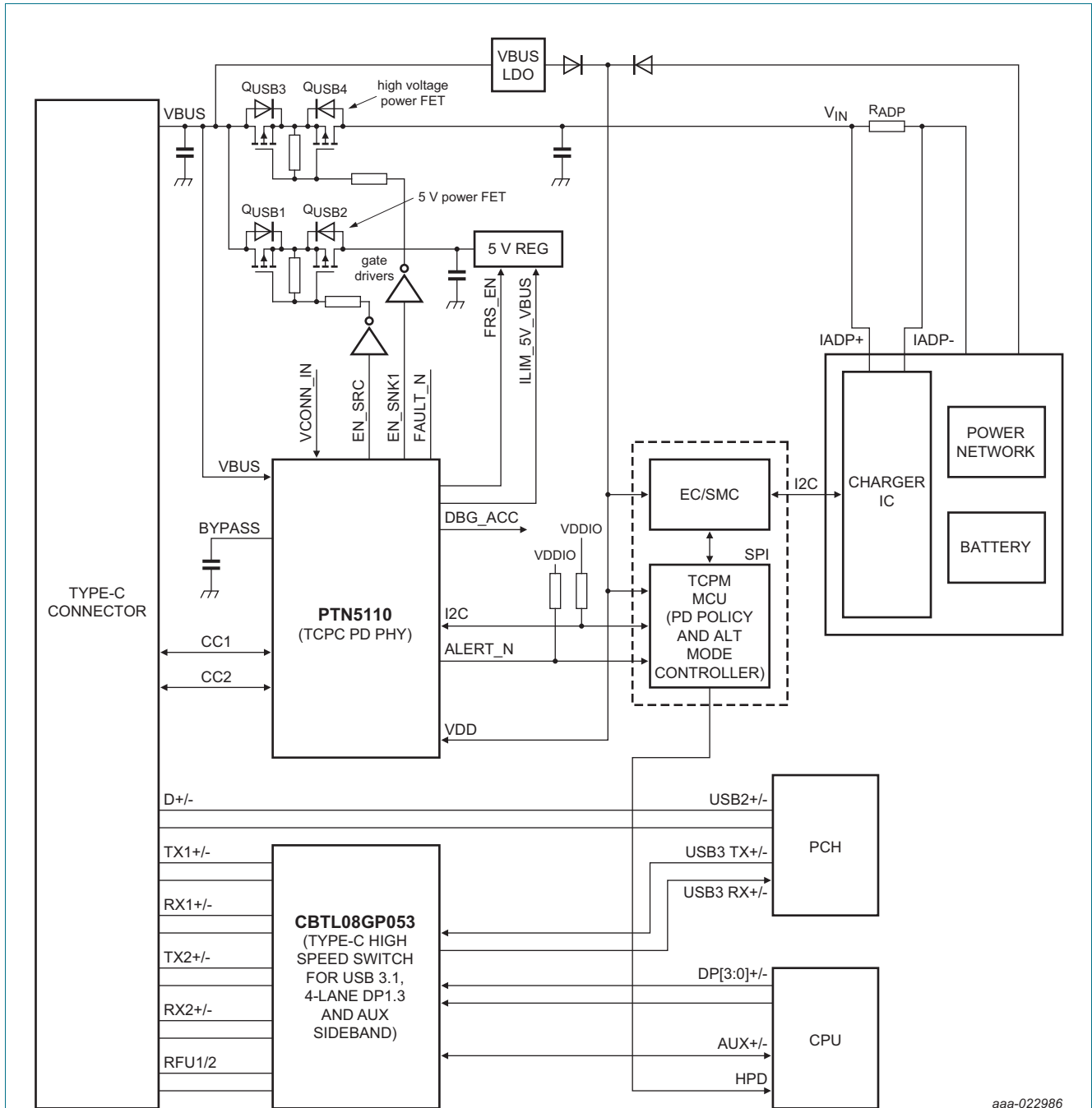

aaa-022986

**Fig 6. Illustrative diagram of Notebook/Ultrabook/Tablet application (Separate source and sink power path FETs): PD Provider/Consumer role (Source role under Normal power/battery; Sink role under dead battery condition); NVDC charger configuration relying on VBUS LDO for TCPM start up under dead battery**

In this configuration, NVDC charger IC is used. To support operation on dead battery, a separate VBUS LDO that provides initial current to start up TCPM and charger IC is utilized.

[Figure 5](#) illustrates the use case using load switches whereas [Figure 6](#) illustrates the same with FETs. It should be noted that in [Figure 6](#), gate drivers are required to drive the MOSFETs.

For this application context, it is recommended to use PTN5110DHQ version of the IC. There is a consideration for making this recommendation here - VBUS LDO regulator power path is assumed to start providing VDD earlier than PTN5110 VBUS debounce time of 15 ms.

If the VDD becomes available later than VBUS debounce time of PTN5110, it is feasible to use PTN5110HQ version.





- sources VBUS 5 V
- sources USB PD power (specific wattage depends on the system application)
- Source VCONN power

PTN5110 controls the load switches to VBUS 5 V and PD power (up to a total of three voltage rails). The handshake with power supply unit is handled at the system level. The voltage transitions (both positive and negative) are also handled by PTN5110.

An important aspect to consider here is that a Desktop PC does not have dead battery condition though it can be unpowered. If not powered, PTN5110 presents 'Rd' on CC pins. After power up initialization, PTN5110 indicates 'Rp'. After PD negotiation, the Desktop platform could deliver higher voltage/current.

DBG\_ACC, ILIM\_5V\_VBUS and FRS\_EN connections can be used based on platform need.

For this application context, it is recommended to use PTN5110THQ version of the IC.

**8.1.4 USB PD DRP (Provider/Consumer: Smartphone use case) Standalone PTN5110**

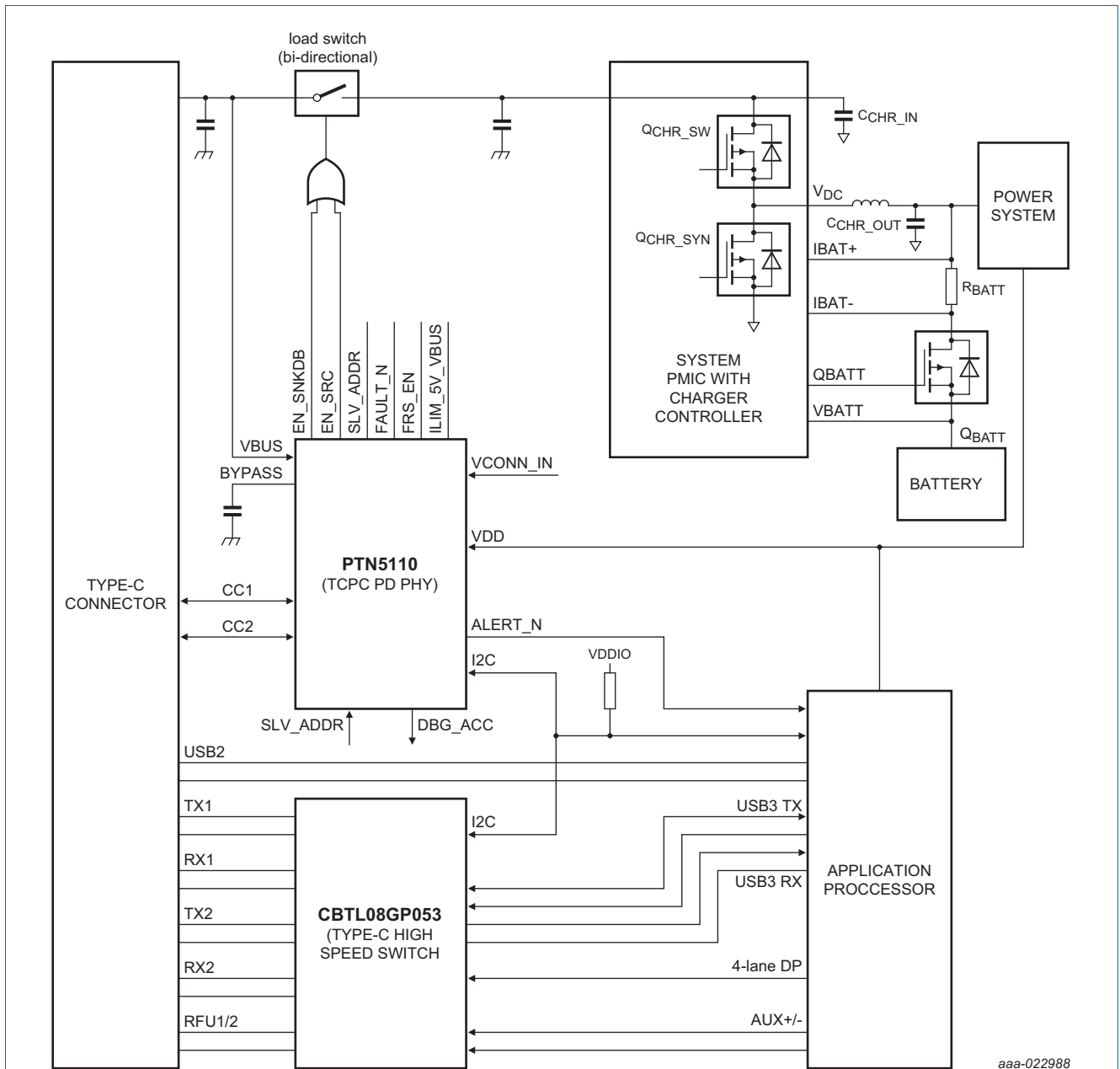

aaa-022988

**Fig 8. Illustrative diagram of Low power devices (e.g. Smartphones) that need 5 V, 3 A only: PD Provider/Consumer (Source role with Sink in dead battery condition and Source/Sink role depending on Type-C Partner capability. The PMIC is assumed to have buck-boost configuration**

In this illustration, PTN5110 is behind Type-C receptacle and it is configured to act as a PD Provider/ Consumer. It is important to note that there is no dedicated policy controller MCU associated with the PD functionality (but Application is used to serve the purpose). Under normal battery/powered condition, PTN5110 is configured as DRP (with Try.SNK

preference) and it performs cable/plug connect and disconnect detection, orientation detection (Application Processor must determine orientation). However, on dead battery condition, it defaults to 'Rd'/Sink role.

The power path control signals (EN\_SNK1, EN\_SRC) handle power flow in one direction each:

- when operating as a Sink, this use case using EN\_SNK1 supports charging of the platform and
- when in Source, EN\_SRC supports power path control of VBUS 5V to the Type-C peripheral.

This application is expected to:

- Sourcing VCONN power is dependent on the Type-C data role taken

The Application processor implements PD and Alt mode functionality.

DBG\_ACC, ILIM\_5V\_VBUS and FRS\_EN connections can be used based on platform need.

For this application context, it is recommended to use PTN5110HQ version of the IC. There is a consideration for making this recommendation here - System PMIC power path is assumed to take longer time than that of PTN5110 VBUS debounce time of 15 ms.

If the VDD becomes available before VBUS debounce time of PTN5110, it is suggested to use PTN5110DHQ version.

8.1.5 Type-C adapters with PTN5110

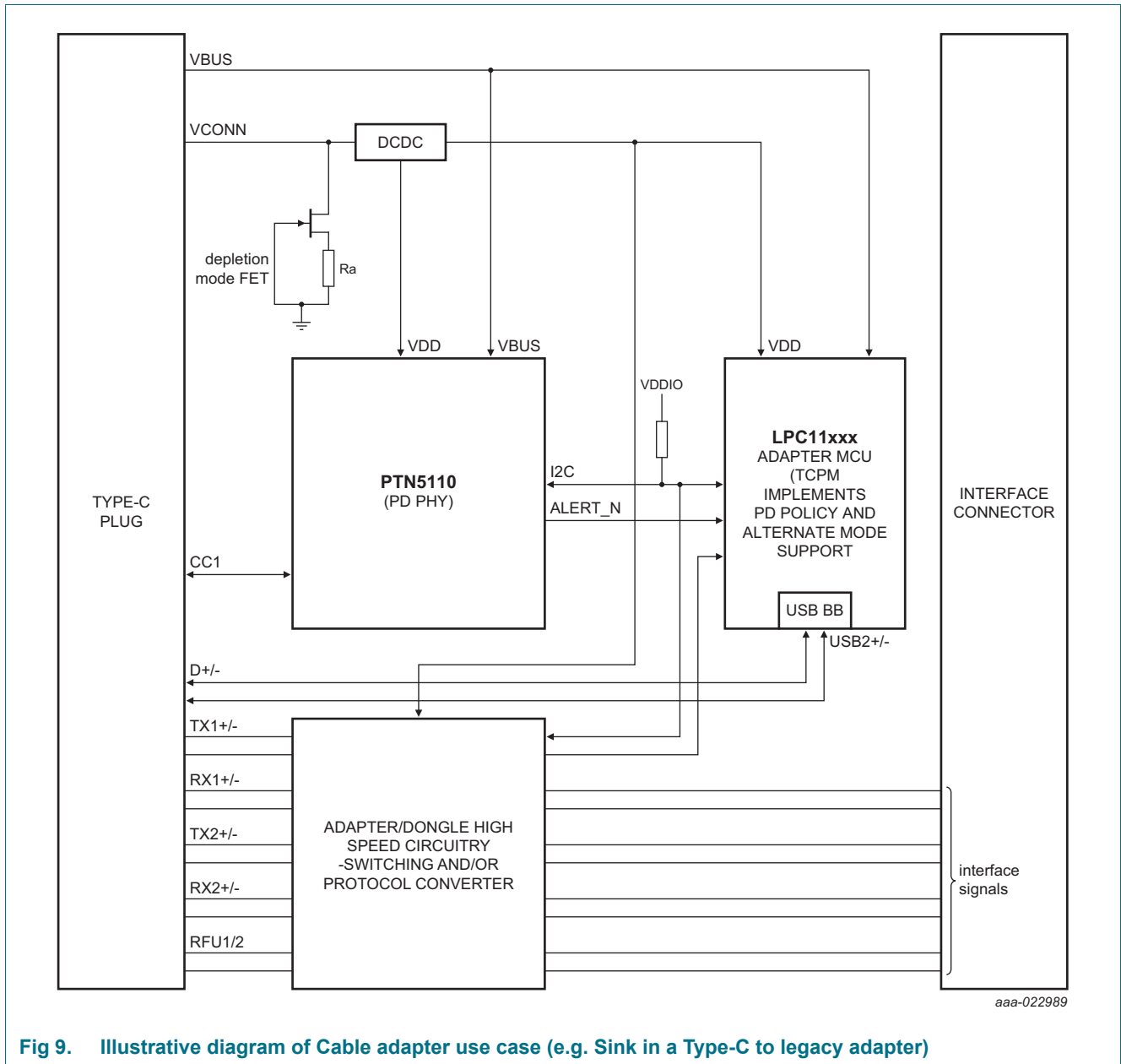

**Fig 9. Illustrative diagram of Cable adapter use case (e.g. Sink in a Type-C to legacy adapter)**

In this illustration, PTN5110 is inside Type-C cable adapter operating in Sink role. Some example use cases are Type-C to DP adapter, Type-C to VGA adapter, Type-C to Thunderbolt adapter etc. PTN5110 serves as PD PHY layer device for a Cable adapter management MCU or dedicated PD MCU wherein PD policy management, Alternate mode and VDM support are handled. The USB Billboard device is assumed to be implemented as part of adapter management MCU.

The cable adapter implementation operates on VCONN supply. Discrete depletion mode FET can be used in the application for 'Ra' indication on CC pin.

For this application context, it is recommended to use PTN5110DHQ version of the IC.



For this application context, it is recommended to use PTN5110DHQ version of the IC.

**8.1.7 USB PD Sink (Consumer) with Type-C receptacle**

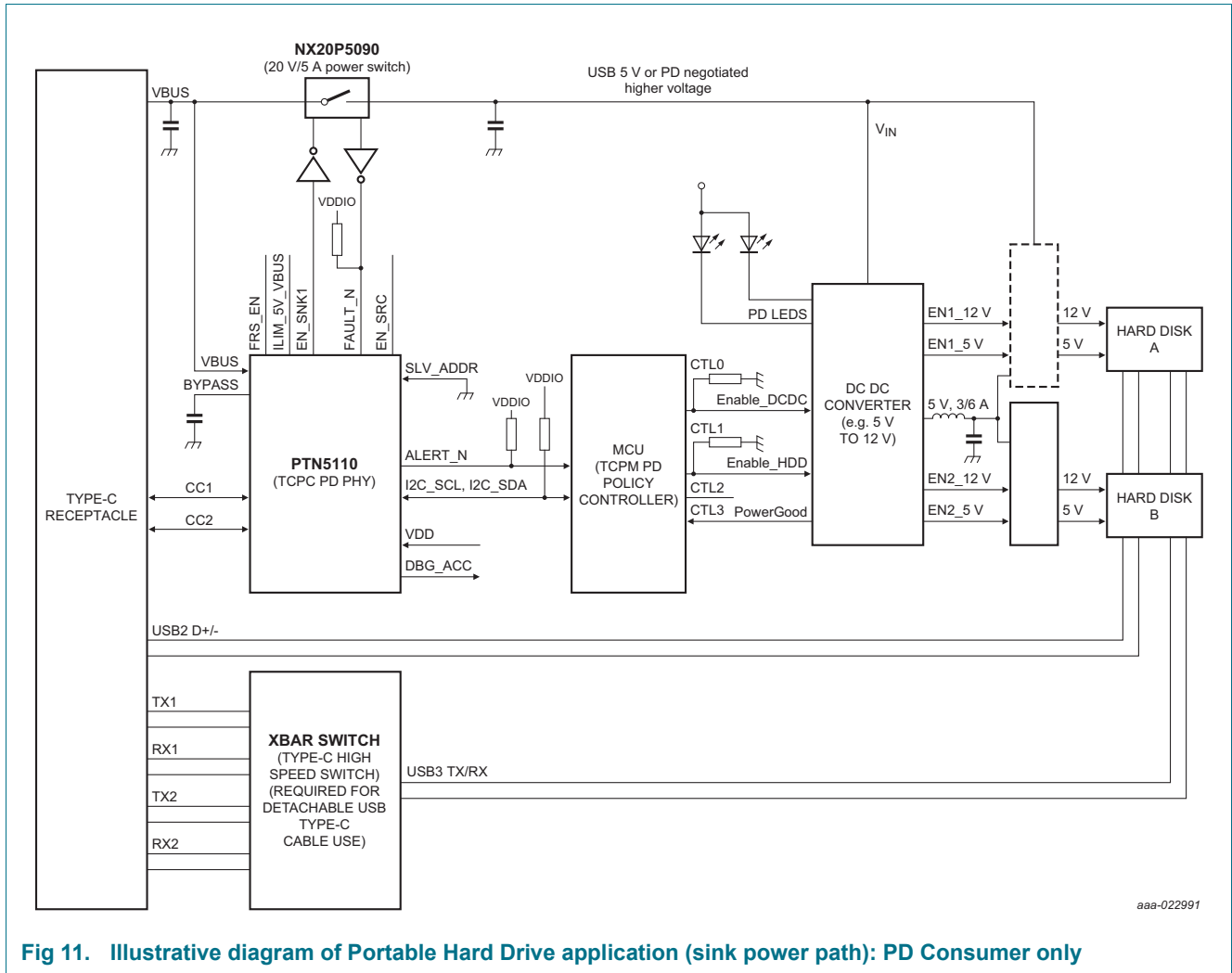

**Fig 11. Illustrative diagram of Portable Hard Drive application (sink power path): PD Consumer only**

In a USB PD based hard drive application, PTN5110 + Policy controller MCU operates autonomously. At POR, PTN5110 presents 'Rd'/Sink role and starts to receive VBUS 5 V. Then based on configured power profile, PD negotiation and contracting is performed. The MCU interfaces with Hard drive electronics and delivers power after handshake. The MCU's GPIO pins can be reused to handshake with DCDC converter and the handshake mechanism is OEM platform dependent.

This application is expected to

- Receive VBUS 5 V, USB PD power

DBG\_ACC, ILIM\_5V\_VBUS and FRS\_EN connections can be used based on platform need.

For this application context, it is recommended to use PTN5110DHQ version of the IC.

8.1.8 Multi-port PD PHY use case

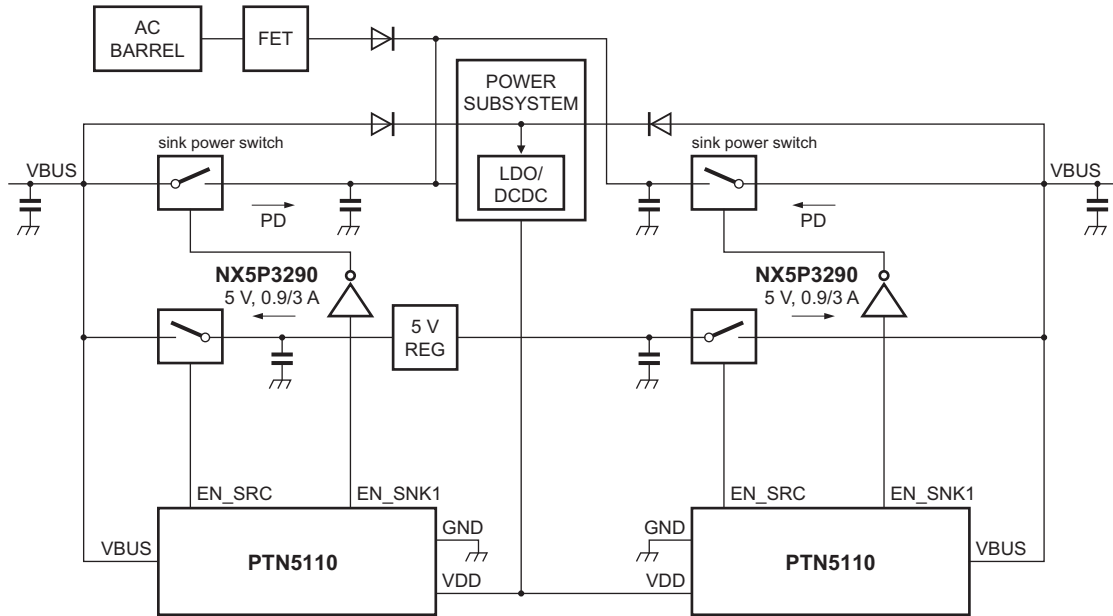

Sourcing 5 V using EN\_SRC  
Sinking VBUS (any voltage) using EN\_SNK1  
Power-ORing of VBUS under dead battery start-up initially

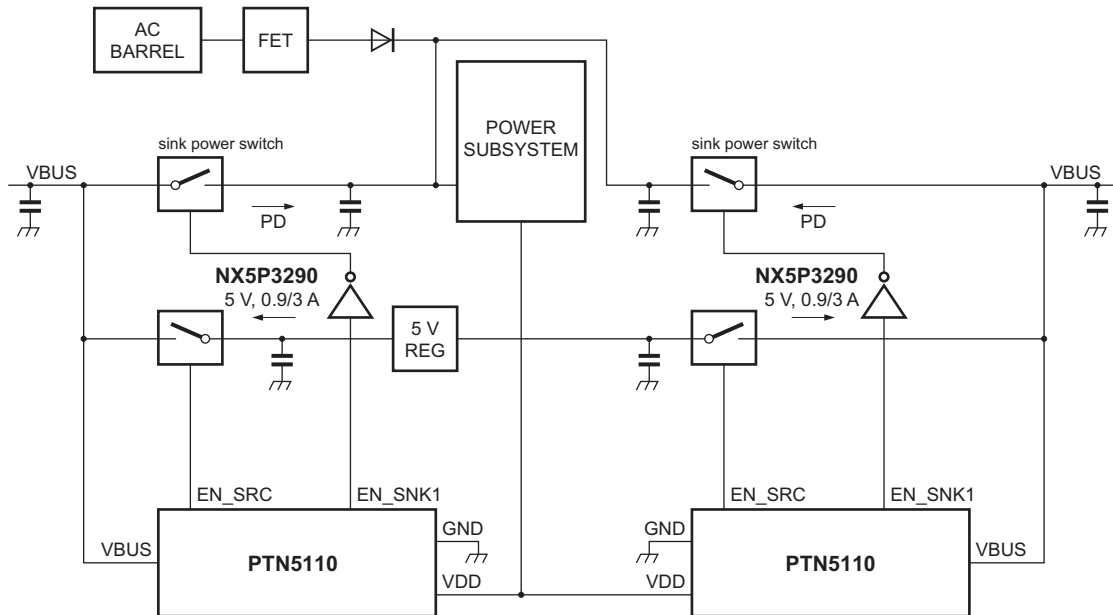

Sourcing 5 V using EN\_SRC  
Sinking VBUS (any voltage) using EN\_SNK1  
Power-ORing of VBUS under dead battery start-up initially

aaa-022992

**Fig 12. Illustrative diagram of Multi-port PD PHY application (Source and Sink power paths): PD Provider/Consumer**

Two example scenarios are captured in the illustrations. This application can be a typical notebook PC with two-port support. Depending on whether the PC uses Buck boost charger or regular NVDC charger, the platform implementation would be different.

For this application context, it is recommended to use PTN5110HQ version of the IC. There is a consideration for making this recommendation here - power subsystem is assumed to take longer time than that of PTN5110 VBUS debounce time of 15 ms.

If the VDD becomes available before VBUS debounce time of PTN5110, it is suggested to use PTN5110DHQ version.



## 9. Limiting values

**Table 9. Limiting values**

*In accordance with the Absolute Maximum Rating System (IEC 60134).*

Symbol	Parameter	Conditions	Min	Max	Unit
VDD	Supply voltage		-0.5	+6.0	V
VBUS	USB VBUS voltage		-0.5	+28	V
V <sub>pullup</sub>	I <sup>2</sup> C pull-up voltage	Applies to I2C_SCL, I2C_SDA	-0.5	+5.5	V
V <sub>I</sub>	Input voltage	voltage at the pin			
		CC1, CC2	-0.5	+6.0	V
		EN_SRC, EN_SNK1	-0.5	+4.6	V
		BYPASS	-0.5	+2.5	V
		VCONN_IN	-0.5	+6.0	V
		ALERT_N	-0.5	+4.6	V
		ILIM_5V_VBUS DBG_ACC, FRS_EN, FAULT_N	-0.5	+4.6	V
		SLV_ADDR I2C_SCL, I2C_SDA	-0.5	+4.6	V
T <sub>stg</sub>	Storage temperature		-65	+150	C
V <sub>ESD</sub>	electrostatic discharge voltage	HBM -VBUS, CC1, CC2	8000	-	V
		HBM for other pins <sup>[4]</sup>	2000		V
		CDM	1000	-	V

- [1] All voltage values, except differential voltages, are with respect to network ground terminal.
- [2] Human Body Model: ANSI/ESDA/JEDEC JDS-001-2012 (Revision of ANSI/ESDA/JEDEC JS-001-2011), ESDA/JEDEC Joint standard for ESD sensitivity testing, Human Body Model - Component level; Electrostatic Discharge Association, Rome, NY, USA; JEDEC Solid State Technology Association, Arlington, VA, USA.
- [3] Charged Device Model: JESD22-C101E December 2009 (Revision of JESD22-C101D, October 2008), standard for ESD sensitivity testing, Charged Device Model - Component level; JEDEC Solid State Technology Association, Arlington, VA, USA.
- [4] Specification valid only with respect to pins other than VBUS, CC1 and CC2.

## 10. Recommended operating conditions

Table 10. Operating conditions

Symbol	Parameter	Conditions	Min	Typ	Max	Unit
VDD	System supply voltage		2.7	3.3	5.5	V
VBUS	USB VBUS voltage		3.9	5	25	V
Vpullup	I <sup>2</sup> C pull-up voltage	I2C_SCL, I2C_SDA	2.7	-	5.5	V
V <sub>I</sub>	input voltage on the pin	CC1, CC2	-0.3	-	5.5	V
		EN_SRC, EN_SNK1	-0.3	-	3.6	V
		VCONN_IN	-0.3	-	5.5	V
		ALERT_N	-0.3	-	3.6	V
		SLV_ADDR	-0.3	-	2.0	V
		ILIM_5V_VBUS DBG_ACC, FRS_EN	-0.3	-	3.6	V
		FAULT_N	-0.3	-	3.6	V
T <sub>amb</sub>	ambient operating temperature		-40	-	+85	°C

## 11. Characteristics

### 11.1 Device characteristics

**Table 11. Device characteristics**

Applicable across operating temperature and power supply ranges as per [Section 10 “Recommended operating conditions”](#) (unless otherwise noted); Typical values are specified at 27 °C (unless otherwise noted); all leakage currents are specified when  $V_{DD} = 0$  (GND) /  $V_{BUS} = 0$  (GND) = GND

Symbol	Parameter	Conditions	Min	Typ	Max	Unit
$I_{DD,Active}$	Active mode operating current on VDD	Sink role; attached condition; I <sup>2</sup> C Clock stretching is enabled on TCPCi interface; VBUS ADC not enabled; VBUS monitoring not enabled; VCONN switch not enabled	-	0.55	0.7	mA
		Source role; attached condition; 3 A current advertisement; I <sup>2</sup> C Clock stretching is enabled on TCPCi interface	-	0.8	1	mA
		Only when PD mode is functional (packet transmission is in progress; this is PD peak current and not steady state current)	-	6.3	8	mA
	Additional current consumed on VDD	VCONN switch is enabled with OCL and RVP; excluding VCONN current flow	-	105	250	μA
	Current drawn on VBUS under dead battery condition	Sink role, VBUS = 5 V, VDD = 0	-	145	-	μA
	Current drawn on VDD for VBUS monitoring, measurement, etc.	VDD = 3.3 V, VBUS = 3.7 V to 25 V (divided via resistor ladder)	-	500	-	μA
$I_{DD(idle)}$	Idle mode current on VDD	Sink role; Unattached condition; I <sup>2</sup> C Clock stretching is enabled on TCPCi interface	-	30	-	μA
		Source role; Unattached condition (Rp at standard current level); I <sup>2</sup> C Clock stretching is enabled on TCPCi interface	-	35	-	μA
		DRP mode; Unattached condition I <sup>2</sup> C Clock stretching is enabled on TCPCi interface	-	40	-	μA
$I_{bckdrv}$	Backdrive current on VDD pin via CC1/2	Backdrive current when VDD = 0, and VBUS = 0				
		CC1/2 = 5.5 V	-10	-	10	μA
$I_{LIH,CC}$	HIGH-level input leakage current on a CC pin	Pin voltage = 5.5 V, VDD = 0, VBUS = 0	-	-	6	mA
$I_{LIL,CC}$	LOW-level input leakage current on a CC pin	Pin pulled to GND, VDD = 0, VBUS = 0	-20	-	-	μA
$t_{FET\_EN}$	Time duration between I <sup>2</sup> C write/ACK response and FET enable asserted	Applicable to all FET control pins	-	-	50	μs

**Table 11. Device characteristics** ...continued

Applicable across operating temperature and power supply ranges as per [Section 10 “Recommended operating conditions”](#) (unless otherwise noted); Typical values are specified at 27 °C (unless otherwise noted); all leakage currents are specified when  $V_{DD} = 0$  (GND) /  $V_{BUS} = 0$  (GND) = GND

Symbol	Parameter	Conditions	Min	Typ	Max	Unit
$t_{FET\_DIS}$	Time duration between I <sup>2</sup> C write/ACK response and FET enable de-asserted	Applicable to all FET control pins	-	-	50	μs
$t_{ADC\_EN}$	Time delay for VBUS monitoring to get activated after the ACK response is sent for the corresponding I <sup>2</sup> C transaction		-	-	250	μs
VBYPASS	voltage on BYPASS pin	capacitance on BYPASS pin=2.2 μF+/-20 %	1.7	-	1.9	V

## 11.2 USB PD and Type-C characteristics

**Table 12. USB PD and Type-C AC/DC characteristics**

Applicable across operating temperature and power supply ranges as per [Section 10 “Recommended operating conditions”](#) (unless otherwise noted). Typical values are specified at 27 °C (unless otherwise noted).

Symbol	Parameter	Conditions	Min	Typ	Max	Unit
<b>USB PD normative specification</b>						
f <sub>Bitrate</sub>	BMC Bit rate		270	300	330	Kbps
t <sub>UI</sub>	Bit Unit Interval		3.03	-	3.7	μs
p <sub>BitRate</sub>	Maximum difference between the bit-rate during the payload and the reference bit-rate (The reference bit rate is the average bit rate of the last 32 bits of the preamble)	During transmission	-	-	0.25	%
t <sub>InterFrameGap</sub>	Time from the end of last bit of a Frame until the start of the first bit of the next Preamble		25	-	-	μs
t <sub>StartDrive</sub>	Time before the start of the first bit of the Preamble when the transmitter shall start driving the line		-1	-	1	μs
<b>USB PD transmitter normative specification</b>						
t <sub>EndDriveBMC</sub>	Time to cease driving the line after the end of the last bit of the Frame	Min value is limited by t <sub>HoldLowBMC</sub>		-	23	μs
t <sub>Fall</sub>	Fall time	10 % and 90 % amplitude points, minimum is under unloaded condition	300	-	-	ns
t <sub>HoldLowBMC</sub>	Time to cease driving the line after the final high-to-low transition	Max value is limited by t <sub>EndDriveBMC</sub>	1	-	-	μs
t <sub>Rise</sub>	Rise time	10 % and 90 % amplitude points, minimum is under unloaded condition	300	-	-	ns
V <sub>Swing</sub>	Voltage swing		1.05	1.125	1.2	V
TX_ONE	“1” level on CC pins during transmitting data		1.05	1.125	1.2	V
TX_ZERO	“0” level on CC pins during transmitting data		0	-	0.075	V
Z <sub>Driver</sub>	Transmitter output impedance	Source output impedance at the Nyquist frequency of [USB2.0] low speed (750 kHz) while the source is driving the CC line.	33	-	75	Ω
r <sub>FRSSwapTx</sub>	FRS request transmit driver resistance (excluding cable resistance)	Maximum driver resistance of a FRS request transmitter	-	-	5	Ω
t <sub>FRSSwapTx</sub>	FRS request transmit duration	FRS request is indicated from the initial Source to the initial Sink by driving CC low for this time	60	-	120	μs

**Table 12. USB PD and Type-C AC/DC characteristics ...continued**

Applicable across operating temperature and power supply ranges as per [Section 10 “Recommended operating conditions”](#) (unless otherwise noted). Typical values are specified at 27 °C (unless otherwise noted).

Symbol	Parameter	Conditions	Min	Typ	Max	Unit
<b>USB PD receiver normative specification</b>						
C <sub>Receiver</sub>	CC Receiver capacitance	The CC pins (Source or Sink) capacitance when not transmitting on the line (including VCONN switch capacitance)	200	-	400	pF
n <sub>TransitionCount</sub>	Transitions for signal detect	Number of transitions to be detected to declare bus non-idle. (USBPD RX Squelch Related)	3	-	-	
t <sub>RxFilter</sub>	Time constant of Rx bandwidth limiting filter	Time constant of a single pole filter to limit broad-band noise ingress	100	-	-	ns
t <sub>TransitionWindow</sub>	Time window for detecting non-idle		12	-	20	μs
Z <sub>BmcRx</sub>	Receiver Input Impedance	Measured from CC pin to GND	1	-	-	MΩ
V <sub>NoiseActive</sub>	Noise amplitude that can be withstood when BMC is active	Peak-to-peak noise from VBUS, USB 2.0 and SBU lines after the Rx bandwidth limiting filter with the time constant ' <i>t<sub>RxFilter</sub></i> ' has been applied	-	-	200	mV
V <sub>NoiseIdle</sub>	Noise amplitude that can be withstood when BMC is idle	Peak-to-peak noise from VBUS, USB 2.0 and SBU lines after the Rx bandwidth limiting filter with the time constant ' <i>t<sub>RxFilter</sub></i> ' has been applied	-	-	300	mV
V <sub>FRSSwapCableTx</sub>	FRS request voltage detection threshold		490	520	550	mV
<b>USB Type-C specification</b>						
V <sub>Vsafe5V</sub>	Vsafe5V range	Steady state value	4	-	5.5	V
V <sub>VBUS,presence</sub>	VBUS present threshold		3.5	-	4	V
V <sub>Vsafe0V</sub>	Vsafe0V threshold		-	-	0.8	V
V <sub>LSB</sub>	VBUS detection LSB voltage		-	25	-	mV
V <sub>VBUSAccuracy</sub>	VBUS detection (absolute) accuracy		-	-	-	
		0 < VBUS < 2.5 V	-50	-	50	mV
		2.5 V < VBUS < 25 V	-2	-	2	%
I <sub>pullup</sub>	Current source for Source pull-up indication	Default current	64	80	96	μA
		1.5 A	166	180	194	μA
		3 A	314	330	346	μA
R <sub>pulldn</sub>	Pull-down termination on Sink	After on-board calibration is completed	4.6	5.1	5.6	kΩ
Z <sub>OPEN</sub>	Sink CC termination	Applies to For self-powered Sink to remain undetectable by Source	126	-	-	kΩ
V <sub>CLAMPH</sub>	High current mode clamp voltage	Sink mode; VDD = 0, VBUS = 0	0.85	-	2.18	V
V <sub>CLAMPM</sub>	Medium current mode clamp voltage	Sink mode; VDD = 0, VBUS = 0	0.45	-	1.25	V

**Table 12. USB PD and Type-C AC/DC characteristics ...continued**

Applicable across operating temperature and power supply ranges as per [Section 10 “Recommended operating conditions”](#) (unless otherwise noted). Typical values are specified at 27 °C (unless otherwise noted).

Symbol	Parameter	Conditions	Min	Typ	Max	Unit
V <sub>CLAMPL</sub>	Default current mode clamp voltage	Sink mode; VDD = 0, VBUS = 0	0.25	-	1.25	V
V <sub>TUM</sub>	Medium current mode detection threshold	Sink mode	1.16	1.23	1.31	V
V <sub>TUS</sub>	Standard current mode detection threshold	Sink mode	0.61	0.66	0.7	V
V <sub>TURa</sub>	Powered Accessory (Ra) mode detection threshold	Sink mode	0.15	0.2	0.25	V
V <sub>TDH,Ra</sub>	High current mode Ra detection threshold	Source mode	0.75	0.8	0.85	V
V <sub>TDM,Ra</sub>	Medium current mode Ra detection threshold	Source mode	0.35	0.4	0.45	V
V <sub>TDS,Ra</sub>	Standard current mode Ra detection threshold	Source mode	0.15	0.2	0.25	V
V <sub>TD,Rd</sub>	Rd detection threshold	Source mode	2.45	2.6	2.75	V

### 11.3 USB VBUS and VCONN timing AC/DC characteristics

**Table 13. USB VBUS and VCONN timing AC/DC characteristics**

(\*applicable when Autonomous Type-C Connection state machine implementation is selected. This is applicable only in 'Ordering option - PTN5110HQ')

Symbol	Parameter	Conditions	Min	Typ	Max	Unit
t* <sub>VBUSSRC_ON</sub>	Time taken for asserting EN_SRC to source VBUS after Sink is attached	Source role; attached condition; including CC debounce	-	-	200	ms
t* <sub>VCONNSRC_ON</sub>	Time duration for providing VCONN on CC pin after EN_SRC is asserted	Source role; attached condition (Ra is detected); VCONN voltage rising to VCONN_IN (min); Load capacitance = 10 μF	-	-	2	ms
t* <sub>VBUSSRC_OFF</sub>	Time taken for deasserting EN_SRC after Sink is detached	Source role; detached condition	-	-	0.5	ms
t* <sub>VCONNSRC_OFF</sub>	Time taken for disconnecting VCONN switch after Sink is detached	Source role; detached condition; VCONN reaches below discharge threshold; Load Capacitance = 10 nF	-	-	1	ms
t <sub>VBUSDISCHG</sub>	Time taken for VBUS discharge	Source role; Load Capacitance = 200 μF max; VBUS pin going from 21.5 V down below Vsafe0V	-	-	650	ms
		Source role; Load Capacitance = 200 μF max; VBUS pin going from 21.5 V down below Vsafe5V (when initial voltage is >5 V)	-	-	275	ms
	Time taken for VBUS discharge after deasserting FET control when Sink is detached	Sink role; Load Capacitance = 100 μF max; VBUS pin going from 21.5 V down below Vsafe0V; disconnect threshold at 17 V	-	-	650	ms
		Sink role; Load Capacitance = 100 μF max; VBUS pin going from 21.5 V down below Vsafe5V (when initial voltage is >5V); disconnect threshold at 17 V	-	-	275	ms
t <sub>VCONNDISCHG</sub>	Time taken for VCONN discharge once I <sup>2</sup> C command for discharging is received	Load Capacitance = 15 μF VCONN going down below V <sub>VCONNDischarge</sub> <sup>[2]</sup>	-	-	30	ms
t* <sub>DRP</sub>	DRP cycle time	Unattached condition	50	-	100	ms
t* <sub>DRPTry</sub>	Wait time in Try.SRC state	Unattached condition	75	-	150	ms
Duty cycle* (for SRC)	Percentage of time that DRP advertise source during t <sub>DRP</sub>	Unattached condition	30	-	70	%
t* <sub>DRPTransition</sub>	Time for DRP to complete transition between Source and Sink roles during role resolution	Unattached condition	0	-	1	ms



### 11.4 VCONN switch characteristics

**Table 14. VCONN switch AC/DC characteristics**

Applicable across operating temperature and power supply ranges as per [Section 10 “Recommended operating conditions”](#) (unless otherwise noted). Typical values are specified at 27 °C (unless otherwise noted).

Symbol	Parameter	Conditions	Min	Typ	Max	Unit
V <sub>VCONN_IN</sub>	VCONN_IN voltage		2.7	-	5.5	V
I <sub>Short</sub>	Trigger value of Current for raising Short-to-GND fault		0.75	-	2.4	A
R <sub>ON</sub>	ON resistance		-	350	450	mΩ
C <sub>ON</sub>	ON capacitance		-	115	-	pF
C <sub>OFF</sub>	OFF capacitance		-	35	-	pF
V <sub>UVLO</sub>	Under voltage lockout threshold on VCONN_IN pin		1.7	-	1.9	V
I <sub>inrush</sub>	Inrush current	When VCONN switch is enabled; corresponding CCx pin voltage is zero; CC capacitance = 10 μF	-	-	100	mA
I <sub>CL</sub>	Current Limiting thresholds	@ threshold of 150 mA	100	160	230	mA
		@ threshold of 300 mA	230	305	375	mA
		@ threshold of 450 mA	375	450	580	mA
		@ threshold of 600 mA	500	600	750	mA
V <sub>dischg</sub>	VCONN Discharge threshold	Discharge resistor removal in Source role	-	-	0.15	V
V <sub>VCONN,present</sub>	VCONN present threshold		-	2.4	2.7	V
I <sub>RLCL</sub>	Reverse Leakage Current from CC to VCONN when switch is not enabled	VCONN = 0; VDD = 2.7 V to 5.5 V	-	-	3	μA
V <sub>RVP</sub>	Reverse Voltage allowed before RVP fault protection is triggered		-	55	100	mV
T <sub>OTP</sub>	Temperature threshold for OTP fault triggering		-	138	-	C
t <sub>OTP,Cycle</sub>	Time interval for VCONN switch re-enabling after OTP fault occurrence		450	-	650	ms
t <sub>dis</sub>	Duration to detect and current limit switch due to Short to GND	With HW based control enabled	-	-	10	μS
	Duration to detect and disable switch due to OTP fault	With HW based control enabled	-	-	10	μS
	Duration to detect and disable switch due to RVP fault	With default fault debounce setting (of 46 μs)	-	-	100	μS

### 11.5 I<sup>2</sup>C characteristics

**Table 15. I<sup>2</sup>C-bus interface: AC/DC characteristics**

Applicable across operating temperature and power supply ranges as per [Section 10 “Recommended operating conditions”](#) (unless otherwise noted). Typical values are specified at 27 °C (unless otherwise noted).

Symbol	Parameter	Conditions	Min	Typ	Max	Unit
F <sub>I2C</sub>	I <sup>2</sup> C Clock frequency		0	-	1000	kHz
V <sub>IH</sub>	HIGH-level Input voltage		0.7x V <sub>pullup</sub>	-	-	V
V <sub>IL</sub>	LOW-level Input voltage		-	-	0.3x V <sub>pullup</sub>	V
V <sub>hys</sub>	Hysteresis of Schmitt trigger inputs	V <sub>pullup</sub> > 2 V	0.05x V <sub>pullup</sub>	-	-	V
V <sub>OL</sub>	LOW-level output voltage at 3mA sink current	V <sub>pullup</sub> > 2 V	0	-	0.4	V
I <sub>OL</sub>	LOW-level output current	V <sub>OL</sub> = 0.4 V; Standard and Fast modes	3	-	-	mA
		V <sub>OL</sub> = 0.4 V; Fast mode plus	20	-	-	mA
		V <sub>OL</sub> = 0.6 V; Fast mode	6	-	-	mA
I <sub>IL</sub>	LOW-level input current	Pin voltage: 0.1xV <sub>pullup</sub> to 0.9x V <sub>pullup</sub> max	-10	-	10	μA
C <sub>I</sub>	Capacitance of IO pin		-	-	10	pF
t <sub>HD,STA</sub>	Hold time (repeated) START condition	Fast mode plus; After this period, the first clock pulse is generated	0.26	-	-	μS
t <sub>LOW</sub>	LOW period of I <sup>2</sup> C clock	Fast mode plus	0.5	-	-	μS
t <sub>HIGH</sub>	HIGH period of I <sup>2</sup> C clock	Fast mode plus	0.26	-	-	μS
t <sub>SU,STA</sub>	Setup time (repeated) START condition	Fast mode plus	0.26	-	-	μS
t <sub>HD,DAT</sub>	Data Hold time	Fast mode plus	0	-	-	μS
t <sub>SU,DAT</sub>	Data Setup time	Fast mode plus	50	-	-	ns
t <sub>r</sub>	Rise time of I2C_SCL and I2C_SDA signals	Fast mode plus	-	-	120	ns
t <sub>f</sub>	Fall time of I2C_SCL and I2C_SDA signals	Fast mode plus	-	-	120	ns
t <sub>SU,STO</sub>	Setup time for STOP condition	Fast mode plus	0.26	-	-	μS
t <sub>BUF</sub>	Bus free time between STOP and START condition	Fast mode plus	0.5	-	-	μS

**Table 15. I<sup>2</sup>C-bus interface: AC/DC characteristics ...continued**

Applicable across operating temperature and power supply ranges as per [Section 10 “Recommended operating conditions”](#) (unless otherwise noted). Typical values are specified at 27 °C (unless otherwise noted).

Symbol	Parameter	Conditions	Min	Typ	Max	Unit
t <sub>VD,DAT</sub>	Data valid time	Fast mode plus		-	0.45	μS
t <sub>VD,ACK</sub>	Data valid acknowledge time	Fast mode plus		-	0.45	μS
t <sub>SP</sub>	Pulse width of spikes that must be suppressed by input filter		0	-	50	ns

[1] V<sub>pullup</sub> is external pull-up voltage on SCL and SDA pins. The voltage can be 2.7 V to 5.5 V but is recommended to be same/close to VDD.

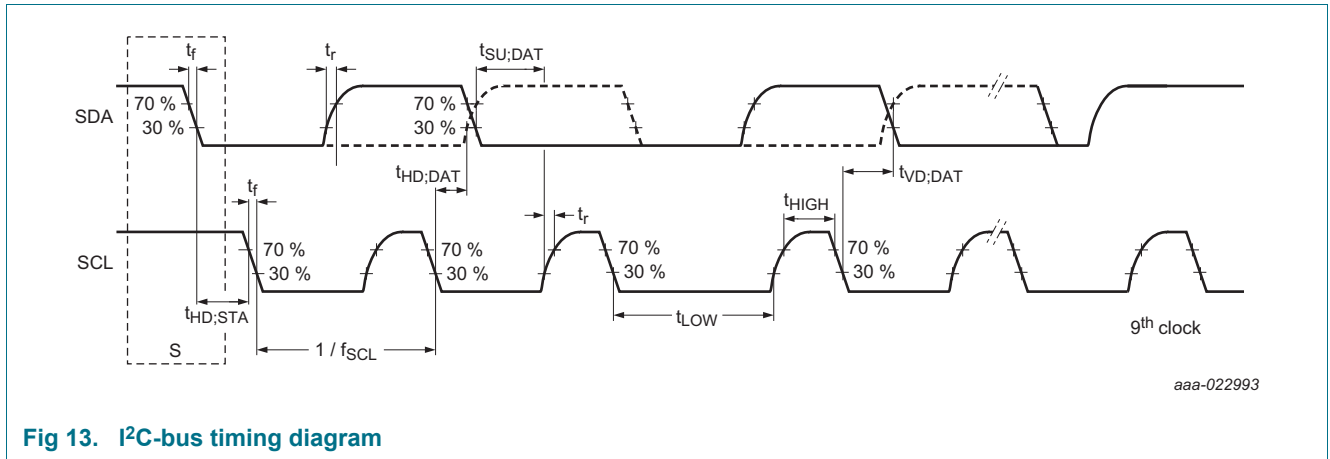

**Fig 13. I<sup>2</sup>C-bus timing diagram**

### 11.6 Control I/O characteristics

**Table 16. Control I/O characteristics**

Applicable across operating temperature and power supply ranges as per [Section 10 “Recommended operating conditions”](#) (unless otherwise noted). Typical values are specified at 27 °C (unless otherwise noted).

Symbol	Parameter	Conditions	Min	Typ	Max	Unit
<b>FET Control pins (EN_SRC, EN_SNK1)</b>						
V <sub>OH</sub>	HIGH-level Output voltage	I <sub>OH</sub> = -1 mA	1.4	-	-	V
V <sub>OL</sub>	LOW-level Output voltage	I <sub>OL</sub> = 1 mA	-	-	0.3	V
C <sub>I</sub>	Capacitance of IO pin		-	-	20	pF
I <sub>LIH</sub>	HIGH-level leakage current	V <sub>I</sub> = 3.3 V	-1	-	10	μA
I <sub>LIL</sub>	LOW-level leakage current	V <sub>I</sub> = GND	-1	-	1	μA
<b>GPIO pins (DBG_ACC, ILIM_5V_VBUS, FRS_EN)</b>						
V <sub>OH</sub>	HIGH-level Output voltage	I <sub>OH</sub> = -1 mA	BYPASS - 0.3	-	-	V
V <sub>OL</sub>	LOW-level Output voltage	I <sub>OL</sub> = 1 mA	-	-	0.3	V
V <sub>IH</sub>	HIGH-level Input voltage		0.7 x BYPASS	-	BYPASS	V
V <sub>IL</sub>	LOW-level Input voltage		-	-	0.3 x BYPASS	V
C <sub>I</sub>	Capacitance of IO pin		-	-	20	pF
I <sub>LIH</sub>	HIGH-level leakage current	V <sub>I</sub> = 3.3 V	-1	-	10	μA
I <sub>LIL</sub>	LOW-level leakage current	V <sub>I</sub> = GND	-1	-	1	μA
<b>Open drain IO pin (ALERT_N, FAULT_N) pulled up by 10 kΩ<sup>[1]</sup></b>						
V <sub>OL</sub>	LOW-level output voltage	I <sub>OL</sub> = 1 mA	-	-	0.5	V
C <sub>I</sub>	Capacitance of IO pin		-	-	20	pF
I <sub>LIH,EN</sub>	HIGH-level leakage current	V <sub>I</sub> = 3.6 V, pulled up by 10 kΩ	-1	-	10	μA
I <sub>LIL,EN</sub>	LOW-level leakage current	V <sub>I</sub> = GND	-1	-	1	μA

**Table 16. Control I/O characteristics ...continued**

Applicable across operating temperature and power supply ranges as per [Section 10 “Recommended operating conditions”](#) (unless otherwise noted). Typical values are specified at 27 °C (unless otherwise noted).

Symbol	Parameter	Conditions	Min	Typ	Max	Unit
<b>SLV_ADDR pin (input)</b>						
$V_{IN, range}$	Input voltage range	When GND		-	50	mV
$C_I$	Capacitance of IO pin		-	-	20	pF
$I_{LIH,EN}$	HIGH-level leakage current	$V_I = \text{BYPASS};$ VDD or VBUS is valid	-1	-	1	$\mu\text{A}$
$I_{LIL,EN}$	LOW-level leakage current	$V_I = \text{GND}$	-1	-	1	$\mu\text{A}$

[1] The pull-up voltage on ALERT\_N pin can be 2.7 V to 5.5 V and it is expected to be same/close to VDD

## 12. Package outline

HX2QFN16: plastic, thermal enhanced super thin quad flat package; no leads;  
16 terminals; body 2.6 x 2.6 x 0.35 mm

SOT1883-1

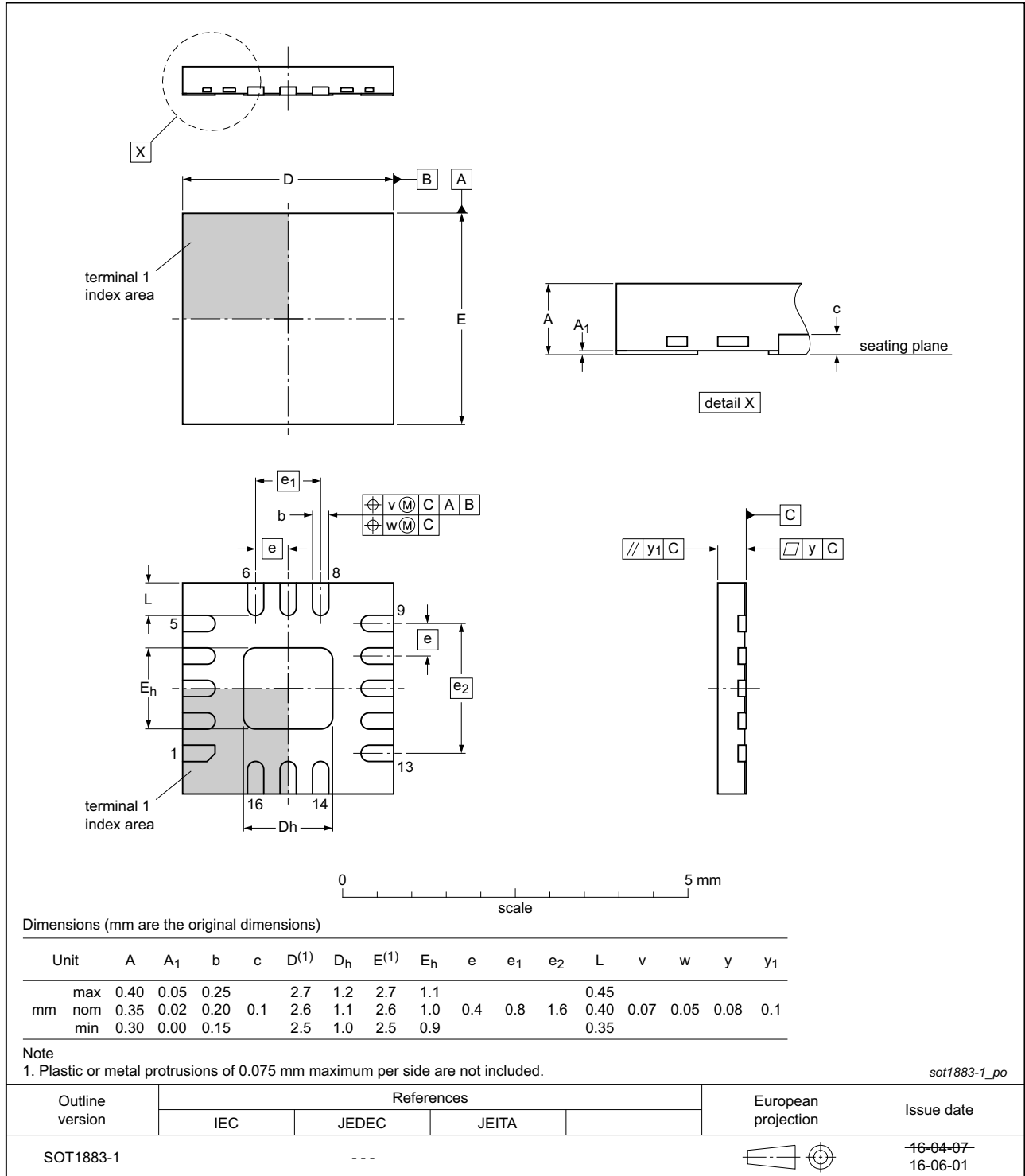
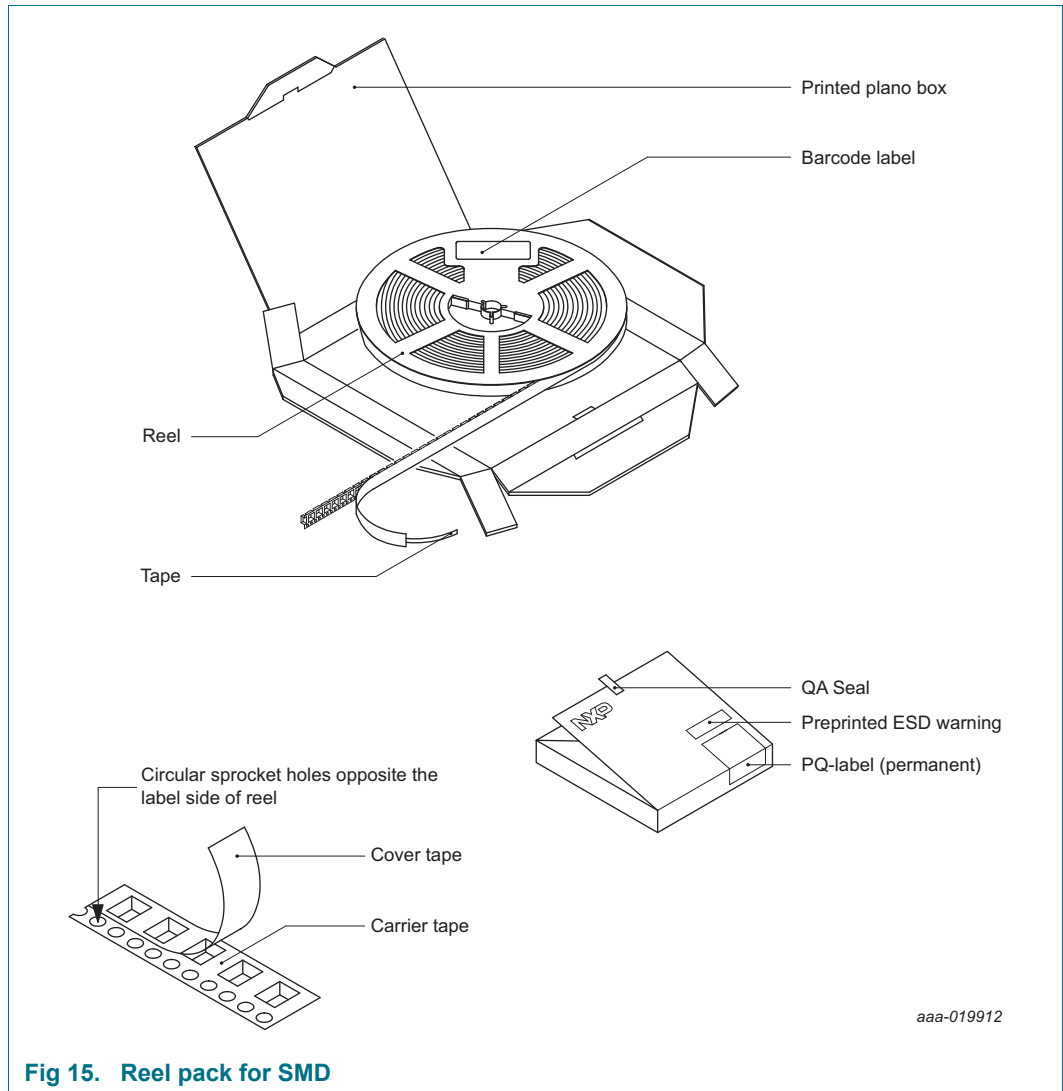

Fig 14. Package outline SOT1883-1 (HX2QFN16)

### 13. Packing information

**13.1 HX2QFN16; Reel pack, SMD, 7"; Q2/T3 standard product orientation; Orderable part number ending ,147 or Z; Ordering code (12NC) ending 147**

#### 13.1.1 Packing method



**Fig 15. Reel pack for SMD**

**Table 17. Dimensions and quantities**

Reel dimensions d × w (mm) [1]	SPQ/PQ (pcs) [2]	Reels per box	Outer box dimensions l × w × h (mm)
180 × 12	4000	1	191 × 191 × 30

[1] d = reel diameter; w = tape width.

[2] Packing quantity dependent on specific product type.

View ordering and availability details at [NXP order portal](#), or contact your local NXP representative.

**13.1.2 Product orientation**

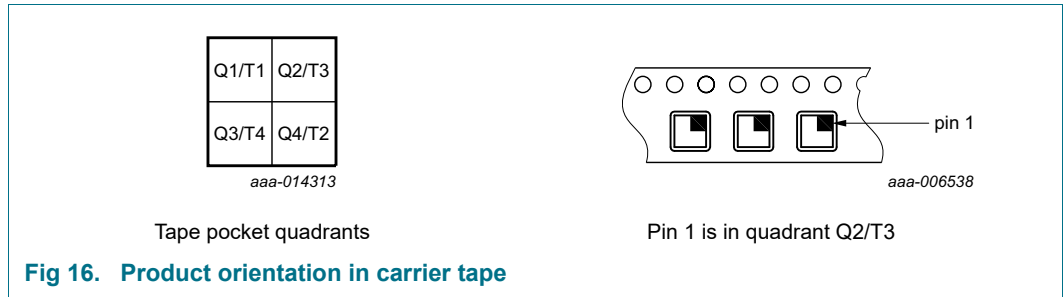

**13.1.3 Carrier tape dimensions**

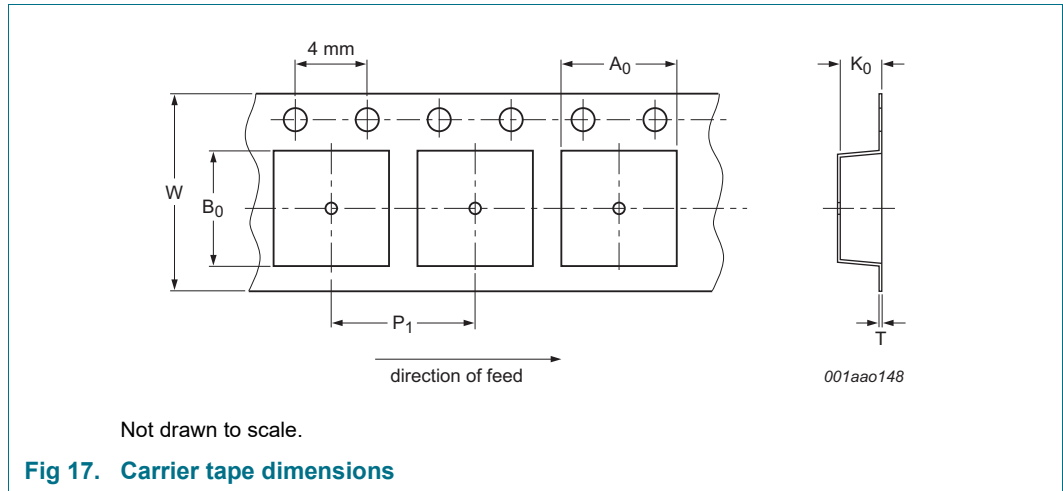

**Table 18. Carrier tape dimensions**

In accordance with IEC 60286-3.

A <sub>0</sub> (mm)	B <sub>0</sub> (mm)	K <sub>0</sub> (mm)	T (mm)	P <sub>1</sub> (mm)	W (mm)
2.80 ± 0.05	2.80 ± 0.05	0.55 ± 0.05	0.20 ± 0.05	4.0 ± 0.1	12.0 ± 0.3



13.1.4 Reel dimensions

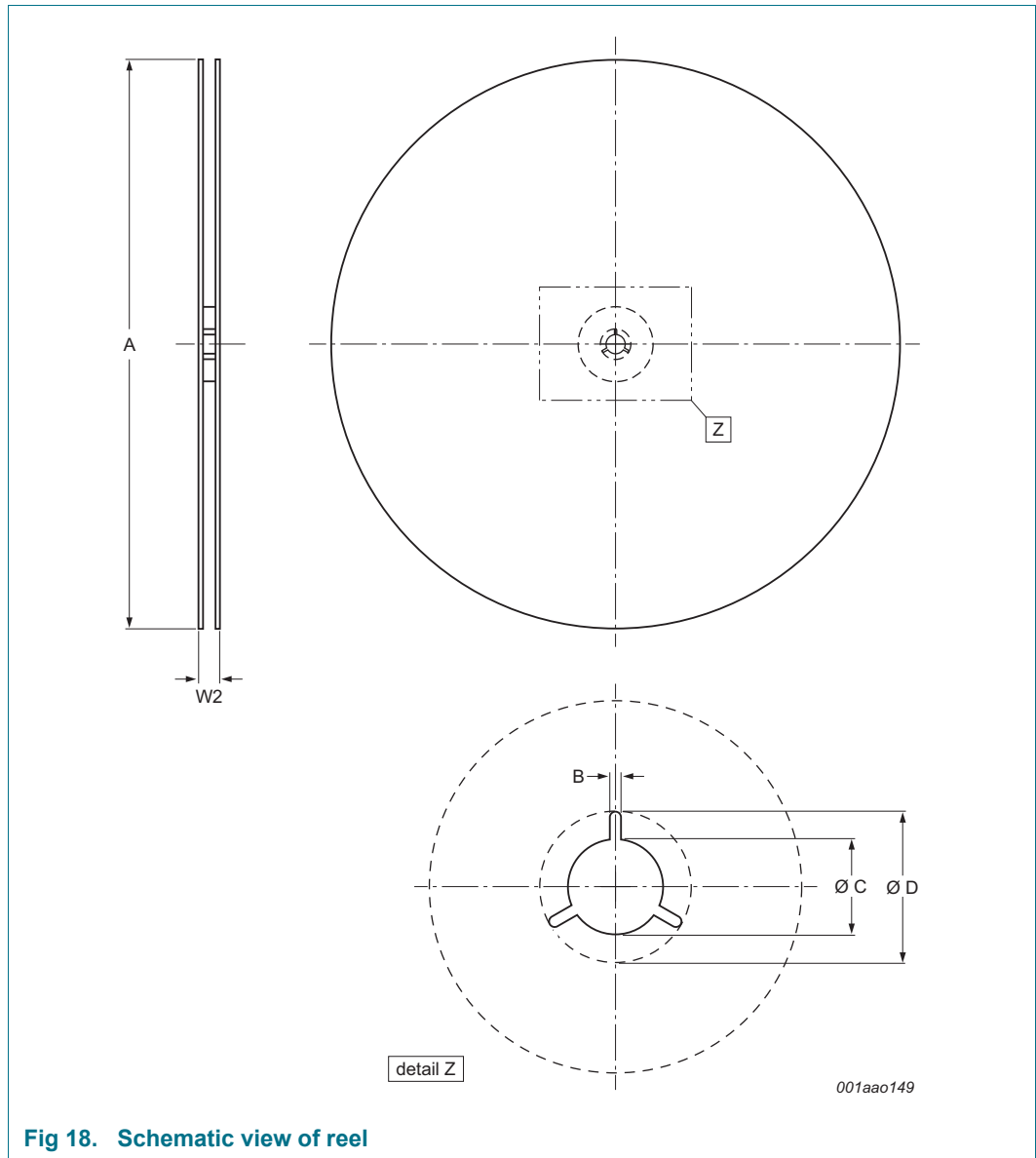

Fig 18. Schematic view of reel

**Table 19. Reel dimensions**  
In accordance with IEC 60286-3.

A [nom] (mm)	W2 [max] (mm)	B [min] (mm)	C [min] (mm)	D [min] (mm)
180	18.4	1.5	12.8	20.2

13.1.5 Barcode label

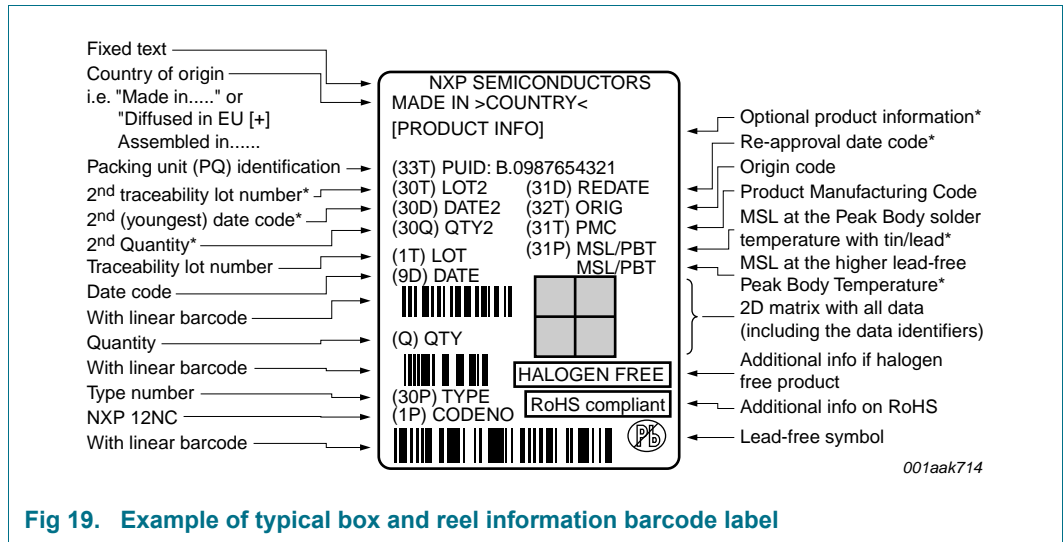

Fig 19. Example of typical box and reel information barcode label

Table 20. Barcode label dimensions

Box barcode label l × w (mm)	Reel barcode label l × w (mm)
100 × 75	100 × 75

## 14. Soldering of SMD packages

This text provides a very brief insight into a complex technology. A more in-depth account of soldering ICs can be found in Application Note *AN10365 “Surface mount reflow soldering description”*.

### 14.1 Introduction to soldering

Soldering is one of the most common methods through which packages are attached to Printed Circuit Boards (PCBs), to form electrical circuits. The soldered joint provides both the mechanical and the electrical connection. There is no single soldering method that is ideal for all IC packages. Wave soldering is often preferred when through-hole and Surface Mount Devices (SMDs) are mixed on one printed wiring board; however, it is not suitable for fine pitch SMDs. Reflow soldering is ideal for the small pitches and high densities that come with increased miniaturization.

### 14.2 Wave and reflow soldering

Wave soldering is a joining technology in which the joints are made by solder coming from a standing wave of liquid solder. The wave soldering process is suitable for the following:

- Through-hole components
- Leaded or leadless SMDs, which are glued to the surface of the printed circuit board

Not all SMDs can be wave soldered. Packages with solder balls, and some leadless packages which have solder lands underneath the body, cannot be wave soldered. Also, leaded SMDs with leads having a pitch smaller than ~0.6 mm cannot be wave soldered, due to an increased probability of bridging.

The reflow soldering process involves applying solder paste to a board, followed by component placement and exposure to a temperature profile. Leaded packages, packages with solder balls, and leadless packages are all reflow solderable.

Key characteristics in both wave and reflow soldering are:

- Board specifications, including the board finish, solder masks and vias
- Package footprints, including solder thieves and orientation
- The moisture sensitivity level of the packages
- Package placement
- Inspection and repair
- Lead-free soldering versus SnPb soldering

### 14.3 Wave soldering

Key characteristics in wave soldering are:

- Process issues, such as application of adhesive and flux, clinching of leads, board transport, the solder wave parameters, and the time during which components are exposed to the wave
- Solder bath specifications, including temperature and impurities

### 14.4 Reflow soldering

Key characteristics in reflow soldering are:

- Lead-free versus SnPb soldering; note that a lead-free reflow process usually leads to higher minimum peak temperatures (see [Figure 20](#)) than a SnPb process, thus reducing the process window
- Solder paste printing issues including smearing, release, and adjusting the process window for a mix of large and small components on one board
- Reflow temperature profile; this profile includes preheat, reflow (in which the board is heated to the peak temperature) and cooling down. It is imperative that the peak temperature is high enough for the solder to make reliable solder joints (a solder paste characteristic). In addition, the peak temperature must be low enough that the packages and/or boards are not damaged. The peak temperature of the package depends on package thickness and volume and is classified in accordance with [Table 21](#) and [22](#)

**Table 21. SnPb eutectic process (from J-STD-020D)**

Package thickness (mm)	Package reflow temperature (°C)	
	Volume (mm <sup>3</sup> )	
	< 350	≥ 350
< 2.5	235	220
≥ 2.5	220	220

**Table 22. Lead-free process (from J-STD-020D)**

Package thickness (mm)	Package reflow temperature (°C)		
	Volume (mm <sup>3</sup> )		
	< 350	350 to 2000	> 2000
< 1.6	260	260	260
1.6 to 2.5	260	250	245
> 2.5	250	245	245

Moisture sensitivity precautions, as indicated on the packing, must be respected at all times.

Studies have shown that small packages reach higher temperatures during reflow soldering, see [Figure 20](#).

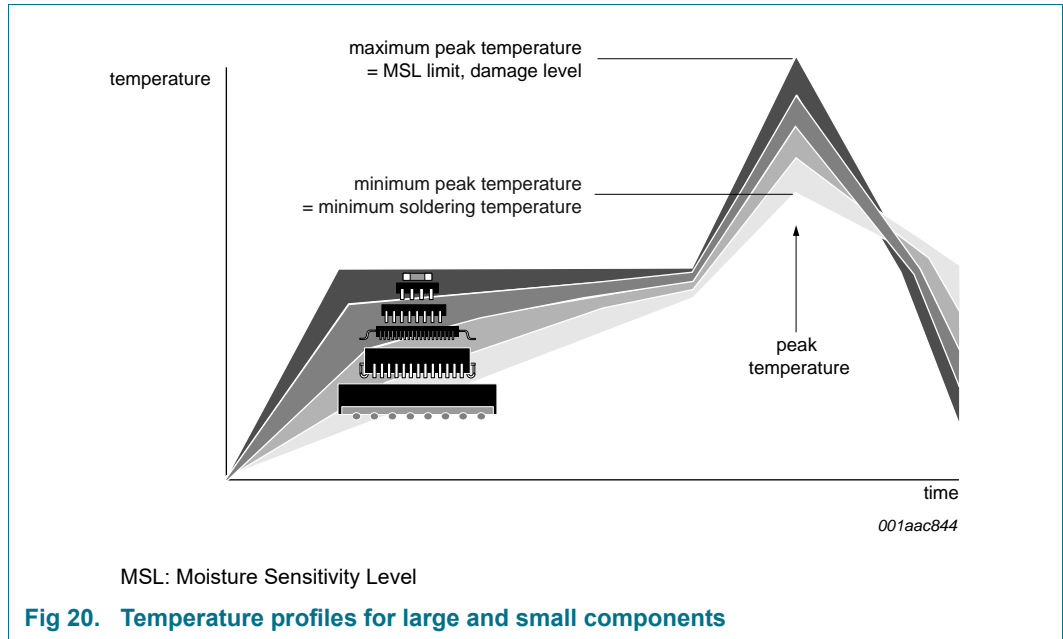

For further information on temperature profiles, refer to Application Note AN10365 “Surface mount reflow soldering description”.

15. Soldering: PCB footprint



All rights are reserved. Reproduction in whole or in part is prohibited without the written consent of the copyright owner.

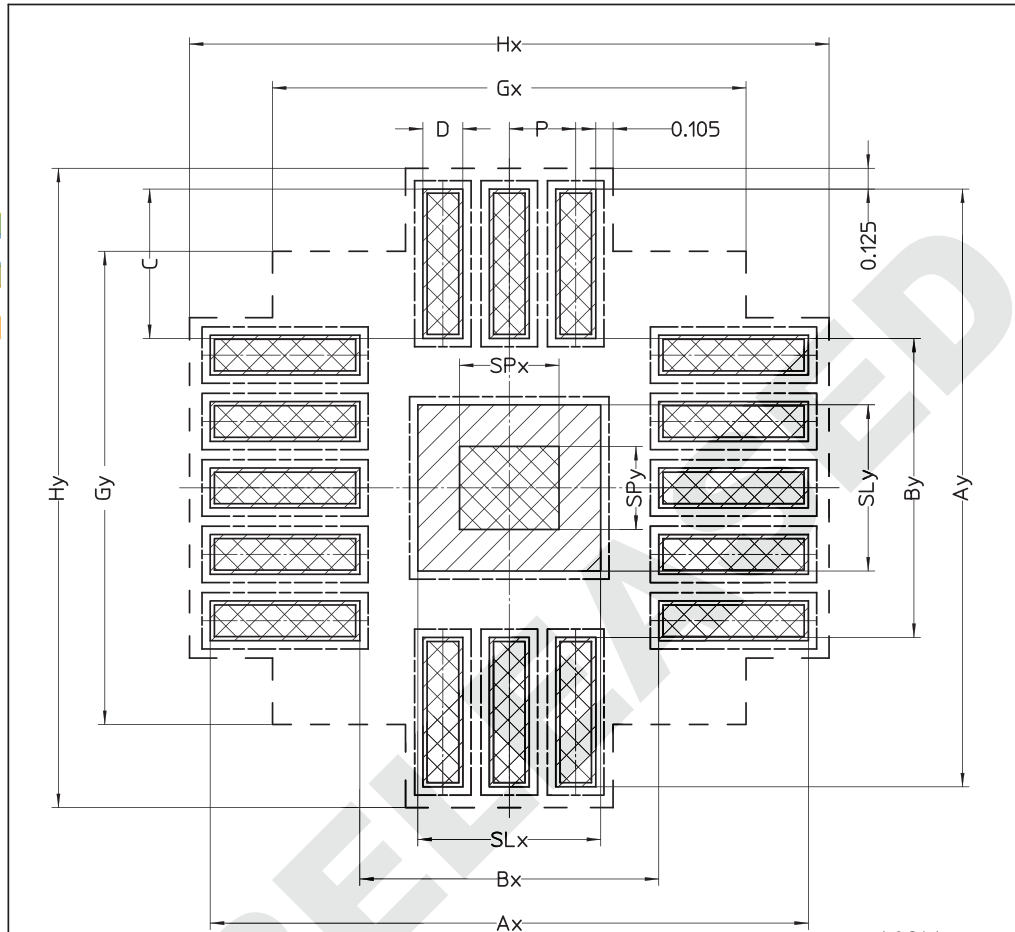

- solder land
- solder paste deposit
- solder resist (0.05mm around Cu)
- occupied area

Recommended stencil thickness: 0.1mm

REFLOW SOLDERING

DIMENSIONS in mm

P	Ax	Ay	Bx	By	SLx	SLy	SPx	SPy	C	D	Gx	Gy	Hx	Hy
0.40	3.60	3.60	1.80	1.80	1.10	1.00	0.60	0.50	0.90	0.24	2.85	2.85	3.85	3.85

Proj.	Scale	Unit	Tol.unless otherw.stated	ISO1302	ISO1101	Typ u a.
	30:1	mm		Ra in $\mu\text{m}$		

SOLDER LAYOUT			EP17081		
SOT1883-1					

Name : SHI Yuning	DWG No. : EP17081	1	110	-	1	010	- - -	A 4
PV	Check :	Dat. : 2017-03-31	(c) NXP Semiconductors / TCC					

Fig 21. PCB footprint for SOT1883-1 (HX2QFN16); reflow soldering

## 16. Abbreviations

**Table 23. Abbreviations**

Acronym	Description
AP	Application Processor
ASIC	Application Specific Integrated Circuit
CDM	Charged Device Model, an ESD standard
CPU	Central Processing Unit
CL	Current Limiting
DBP	Dead Battery Provisioning
DFP	Downstream Facing Port
DRP	Dual Role Port
EC	Embedded Controller
FCP	Forward Current Protection
FS	USB Full Speed signaling
FRS	Fast Role Swap
HBM	Human Body Model, an ESD standard
HS	USB High Speed signaling
LDO	Low Drop-Out regulator
LS	USB Low Speed signaling
MM	Machine Model, an ESD standard
OC	Over-Current condition
OCL	Over-Current Limiting, a form of Over-Current Protection
OTP	Over Temperature Protection
OVP	Over Voltage Protection
PCH	Platform Controller Hub
PD	Power Delivery specification
PMIC	Power Management IC
POR	Power ON Reset
RCP	Reverse Current Protection
RVP	Reverse Voltage Protection
SMC	System Management Controller
SS	USB3.0 Super Speed Signaling
TCPC	Type-C Port Controller
TCPCI	Type-C Port Controller Interface
TCPM	Type-C Port Manager
UFP	Upstream Facing Port
USB	Universal Serial Bus

## 17. References

---

- [1] USB Power Delivery Specification Revision 3.0, Version 1.1 January 12, 2017 (<http://www.usb.org/developers/docs/>)
- [2] USB Type-C Cable and Connector Specification Revision 1.2, March 25, 2016 (<http://www.usb.org/developers/docs/>)
- [3] USB Type-C Port Controller Interface Specification, Rev 2.0, Version 1.0, October 2017 (<http://www.usb.org/developers/docs/>)
- [4] UM10204, "I<sup>2</sup>C-bus specification and user manual"; NXP Semiconductors, Revision 06 April 4, 2014
- [5] PTN5110 Application Programming guide; contact NXP for more information



## 18. Revision history

Table 24. Revision history

Document ID	Release date	Data sheet status	Change notice	Supersedes
PTN5110 v1.6	20200403	Product data sheet	-	PTN5110 v1.5
Modifications:	<ul style="list-style-type: none"> <li>Added PTN5110NTHQ, PTN5110NDHQ</li> </ul>			
PTN5110 v1.5	20180125	Product data sheet	-	PTN5110 v1.4
Modifications:	<ul style="list-style-type: none"> <li>Minor text edits throughout</li> <li>Updated <a href="#">Section 17 “References”</a></li> <li>Updated <a href="#">Figure 1</a>, <a href="#">Figure 2</a>, <a href="#">Figure 3</a>, <a href="#">Figure 8</a>, <a href="#">Figure 9</a>, <a href="#">Figure 10</a></li> </ul>			
PTN5110 v1.4	20170728	Product data sheet	-	PTN5110 v1.3
Modifications:	<ul style="list-style-type: none"> <li><a href="#">Figure 11</a> Replaced “CBTL04GP043” with “XBAR switch” in Type-C high speed switch block</li> </ul>			
PTN5110 v1.3	20170710	Product data sheet	-	PTN5110 v1.2
Modifications:	<ul style="list-style-type: none"> <li>Added <a href="#">Section 15 “Soldering: PCB footprint”</a></li> </ul>			
PTN5110 v1.2	20170628	Product data sheet	-	PTN5110 v1.1
Modifications:	<ul style="list-style-type: none"> <li><a href="#">Section 4 “Ordering information”</a>: Added PTN5110NHQ</li> <li><a href="#">Table 4 “Pin description”</a>: Updated description for DBG_ACC</li> </ul>			
PTN5110 v1.1	20170418	Product data sheet	-	PTN5110 v1.0
Modifications:	<ul style="list-style-type: none"> <li>Added <a href="#">Table 2 “Ordering options and their specific characteristics”</a></li> <li>Added system use case recommendations to <a href="#">Section 8 “Use case view”</a></li> </ul>			
PTN5110 v1.0	20170202	Product data sheet	-	-

## 19. Legal information

### 19.1 Data sheet status

Document status <sup>[1][2]</sup>	Product status <sup>[3]</sup>	Definition
Objective [short] data sheet	Development	This document contains data from the objective specification for product development.
Preliminary [short] data sheet	Qualification	This document contains data from the preliminary specification.
Product [short] data sheet	Production	This document contains the product specification.

[1] Please consult the most recently issued document before initiating or completing a design.

[2] The term 'short data sheet' is explained in section "Definitions".

[3] The product status of device(s) described in this document may have changed since this document was published and may differ in case of multiple devices. The latest product status information is available on the Internet at URL <http://www.nxp.com>.

### 19.2 Definitions

**Draft** — The document is a draft version only. The content is still under internal review and subject to formal approval, which may result in modifications or additions. NXP Semiconductors does not give any representations or warranties as to the accuracy or completeness of information included herein and shall have no liability for the consequences of use of such information.

**Short data sheet** — A short data sheet is an extract from a full data sheet with the same product type number(s) and title. A short data sheet is intended for quick reference only and should not be relied upon to contain detailed and full information. For detailed and full information see the relevant full data sheet, which is available on request via the local NXP Semiconductors sales office. In case of any inconsistency or conflict with the short data sheet, the full data sheet shall prevail.

**Product specification** — The information and data provided in a Product data sheet shall define the specification of the product as agreed between NXP Semiconductors and its customer, unless NXP Semiconductors and customer have explicitly agreed otherwise in writing. In no event however, shall an agreement be valid in which the NXP Semiconductors product is deemed to offer functions and qualities beyond those described in the Product data sheet.

### 19.3 Disclaimers

**Limited warranty and liability** — Information in this document is believed to be accurate and reliable. However, NXP Semiconductors does not give any representations or warranties, expressed or implied, as to the accuracy or completeness of such information and shall have no liability for the consequences of use of such information. NXP Semiconductors takes no responsibility for the content in this document if provided by an information source outside of NXP Semiconductors.

In no event shall NXP Semiconductors be liable for any indirect, incidental, punitive, special or consequential damages (including - without limitation - lost profits, lost savings, business interruption, costs related to the removal or replacement of any products or rework charges) whether or not such damages are based on tort (including negligence), warranty, breach of contract or any other legal theory.

Notwithstanding any damages that customer might incur for any reason whatsoever, NXP Semiconductors' aggregate and cumulative liability towards customer for the products described herein shall be limited in accordance with the *Terms and conditions of commercial sale* of NXP Semiconductors.

**Right to make changes** — NXP Semiconductors reserves the right to make changes to information published in this document, including without limitation specifications and product descriptions, at any time and without notice. This document supersedes and replaces all information supplied prior to the publication hereof.

**Suitability for use** — NXP Semiconductors products are not designed, authorized or warranted to be suitable for use in life support, life-critical or safety-critical systems or equipment, nor in applications where failure or malfunction of an NXP Semiconductors product can reasonably be expected to result in personal injury, death or severe property or environmental damage. NXP Semiconductors and its suppliers accept no liability for inclusion and/or use of NXP Semiconductors products in such equipment or applications and therefore such inclusion and/or use is at the customer's own risk.

**Applications** — Applications that are described herein for any of these products are for illustrative purposes only. NXP Semiconductors makes no representation or warranty that such applications will be suitable for the specified use without further testing or modification.

Customers are responsible for the design and operation of their applications and products using NXP Semiconductors products, and NXP Semiconductors accepts no liability for any assistance with applications or customer product design. It is customer's sole responsibility to determine whether the NXP Semiconductors product is suitable and fit for the customer's applications and products planned, as well as for the planned application and use of customer's third party customer(s). Customers should provide appropriate design and operating safeguards to minimize the risks associated with their applications and products.

NXP Semiconductors does not accept any liability related to any default, damage, costs or problem which is based on any weakness or default in the customer's applications or products, or the application or use by customer's third party customer(s). Customer is responsible for doing all necessary testing for the customer's applications and products using NXP Semiconductors products in order to avoid a default of the applications and the products or of the application or use by customer's third party customer(s). NXP does not accept any liability in this respect.

**Limiting values** — Stress above one or more limiting values (as defined in the Absolute Maximum Ratings System of IEC 60134) will cause permanent damage to the device. Limiting values are stress ratings only and (proper) operation of the device at these or any other conditions above those given in the Recommended operating conditions section (if present) or the Characteristics sections of this document is not warranted. Constant or repeated exposure to limiting values will permanently and irreversibly affect the quality and reliability of the device.

**Terms and conditions of commercial sale** — NXP Semiconductors products are sold subject to the general terms and conditions of commercial sale, as published at <http://www.nxp.com/profile/terms>, unless otherwise agreed in a valid written individual agreement. In case an individual agreement is concluded only the terms and conditions of the respective agreement shall apply. NXP Semiconductors hereby expressly objects to applying the customer's general terms and conditions with regard to the purchase of NXP Semiconductors products by customer.

**No offer to sell or license** — Nothing in this document may be interpreted or construed as an offer to sell products that is open for acceptance or the grant, conveyance or implication of any license under any copyrights, patents or other industrial or intellectual property rights.

**Export control** — This document as well as the item(s) described herein may be subject to export control regulations. Export might require a prior authorization from competent authorities.

**Quick reference data** — The Quick reference data is an extract of the product data given in the Limiting values and Characteristics sections of this document, and as such is not complete, exhaustive or legally binding.

**Non-automotive qualified products** — Unless this data sheet expressly states that this specific NXP Semiconductors product is automotive qualified, the product is not suitable for automotive use. It is neither qualified nor tested in accordance with automotive testing or application requirements. NXP Semiconductors accepts no liability for inclusion and/or use of non-automotive qualified products in automotive equipment or applications.

In the event that customer uses the product for design-in and use in automotive applications to automotive specifications and standards, customer (a) shall use the product without NXP Semiconductors' warranty of the

product for such automotive applications, use and specifications, and (b) whenever customer uses the product for automotive applications beyond NXP Semiconductors' specifications such use shall be solely at customer's own risk, and (c) customer fully indemnifies NXP Semiconductors for any liability, damages or failed product claims resulting from customer design and use of the product for automotive applications beyond NXP Semiconductors' standard warranty and NXP Semiconductors' product specifications.

**Translations** — A non-English (translated) version of a document is for reference only. The English version shall prevail in case of any discrepancy between the translated and English versions.

## 19.4 Trademarks

Notice: All referenced brands, product names, service names and trademarks are the property of their respective owners.

## 20. Contact information

For more information, please visit: <http://www.nxp.com>

For sales office addresses, please send an email to: [salesaddresses@nxp.com](mailto:salesaddresses@nxp.com)