

COVER REMOVED

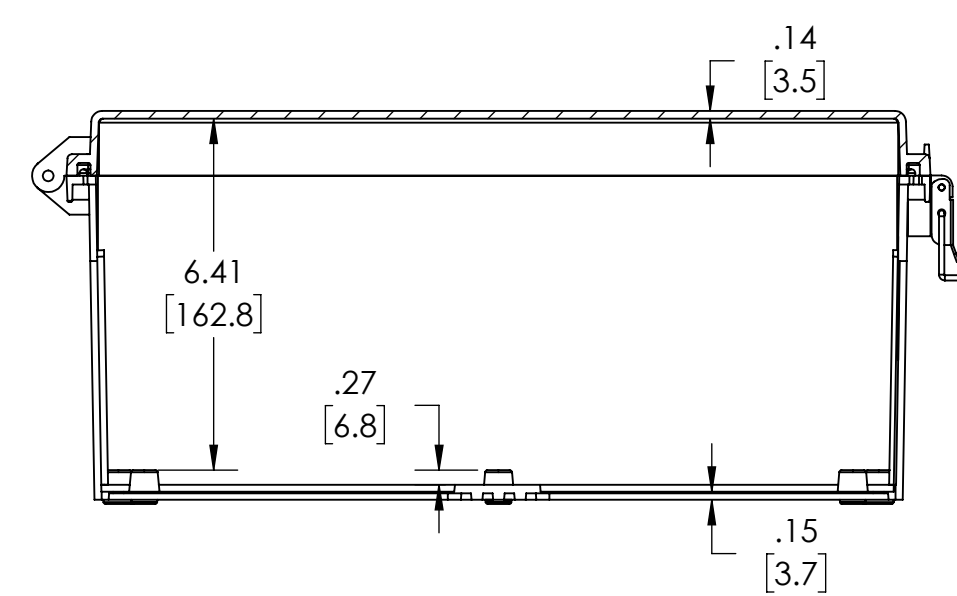

SECTION A-A

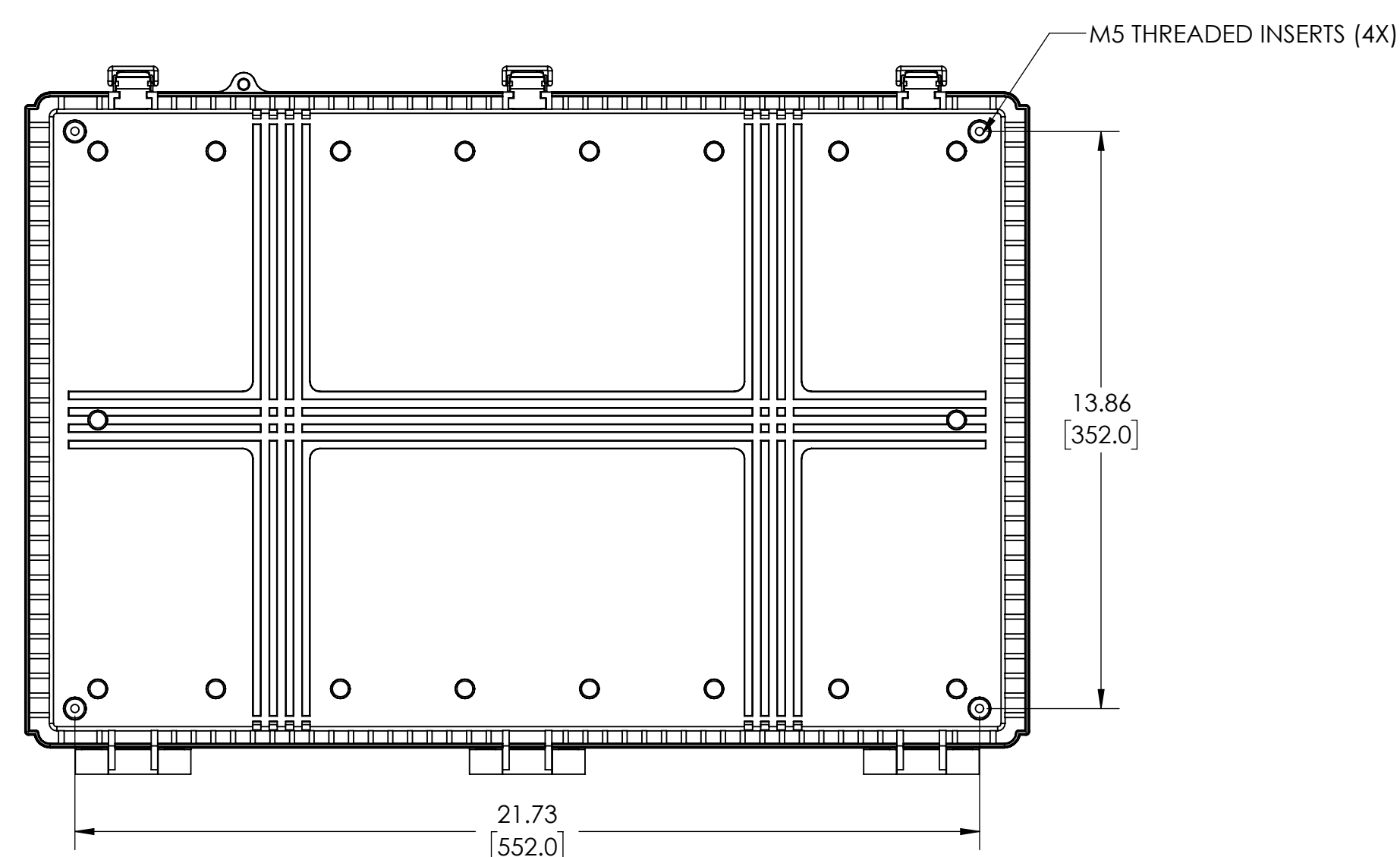
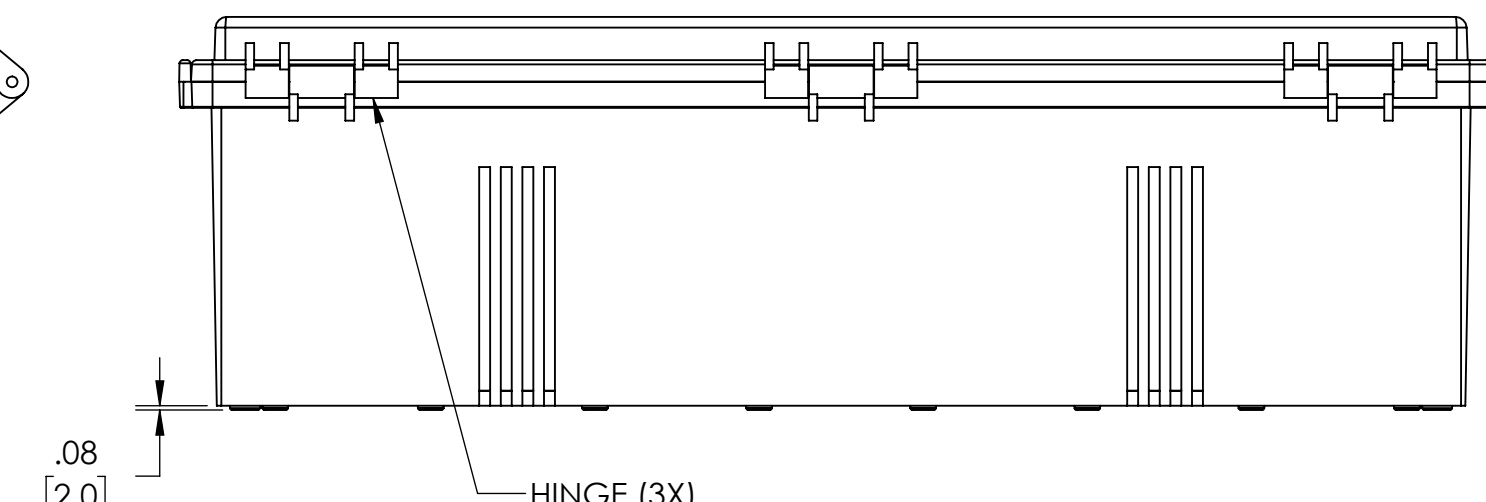
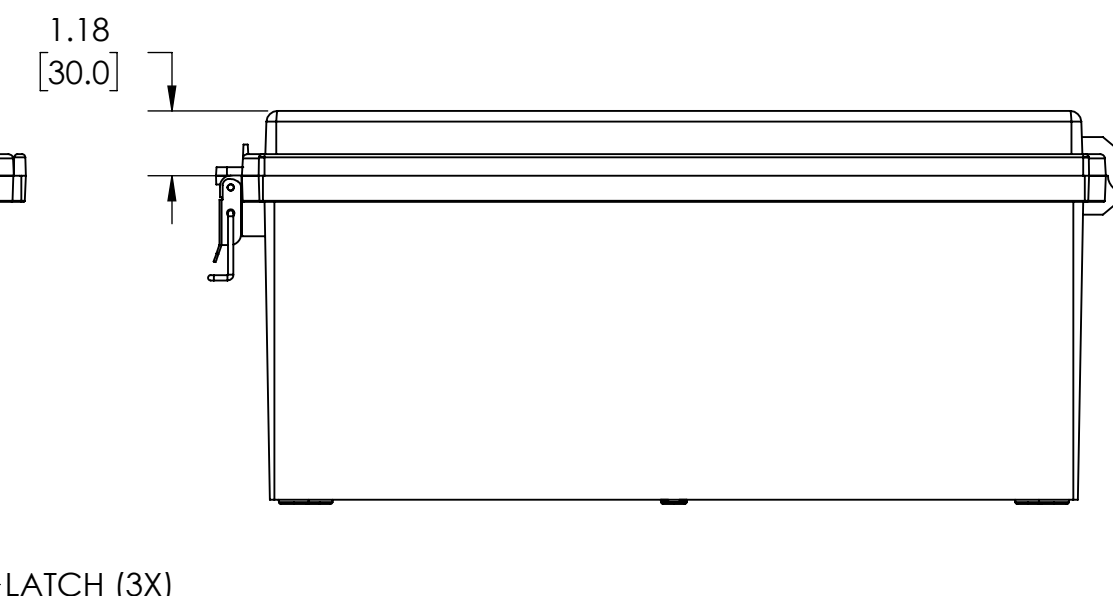
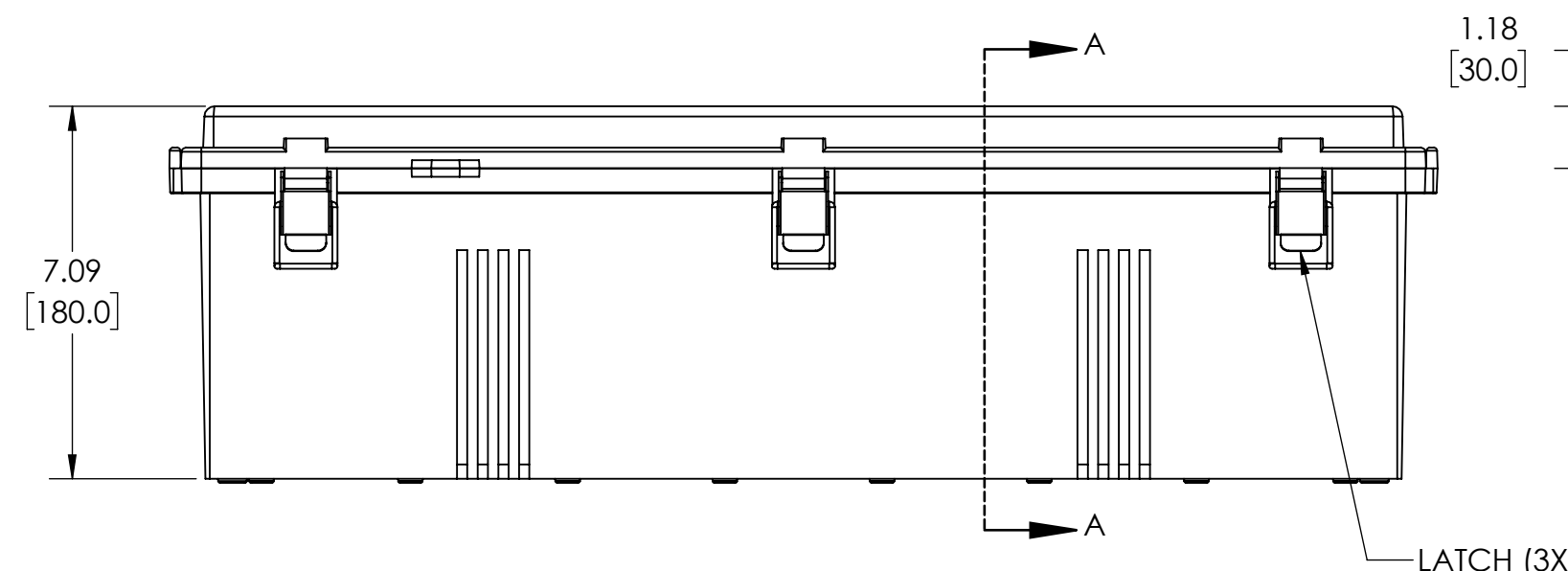

## NOTES:

1. MATERIAL: BODY - POLYCARBONATE 10% FIBERGLASS REINFORCED  
COVER - POLYCARBONATE  
UL508 /NEMA TYPE 4X WITH IP-67 TUV RATING & UL-94V0 RATING
2. FINISH: BODY - LIGHT GRAY  
COVER - LIGHT GRAY OR CLEAR (-C)
3. CONTINUOUS GASKET IN COVER
4. SUPPLIED WITH TWO M5 x 9mm LG. TRUSS HEAD MACHINE SCREWS
5. DIMENSIONS ARE INCH [MM]

**DRAWING FOR REFERENCE**  
WE RESERVE THE RIGHT TO MAKE CHANGES TO OUR  
STANDARD PRODUCTS. PLEASE CONSULT WITH BUD INDUSTRIES  
PRIOR TO USING THIS DRAWING FOR DESIGN PURPOSE.