

PTS0603

SMD PTC fuses



Product features

- Positive temperature coefficient (PTC)
- Surface mount resettable fuse
- Low resistance
- Compact 0603 (1608 metric) footprint
- Voltage rating 6 V to 15 V
- Current rating from 0.04 A to 0.35 A
- Fast time-to-trip

Applications

- Data ports
- Micromotors and fans
- Low voltage test and measurement
- Low voltage hand held equipment
- PC-based medical equipment
- USB protection
- Secondary Li-ion battery protection
- Game consoles, set top boxes
- Battery charging & charging connections

Agency information

- cURus Recognized file no. E343021
- TUV: File R 50506608



Environmental compliance



Part number system/ordering:

PTS060315V004

- PT= PTC resettable fuse
- S= Surface mount
- 0603= Dimension code
- 15V= Maximum voltage
- 004= Ihold current rating (004= 0.04 A)

Product specifications

Part number	V _{max} ¹	I _{max} ²	I _{hold} ³	I _{trip} ⁴	P _d ⁵	Time-to-trip (maximum)		Resistance ⁶		Safety approvals	
	(V _{dc})	(A)	(A)	(A)	typical (W)	(A)	(seconds)	Initial (R _i) minimum (Ω)	Post trip (R ₁) maximum (Ω)	cURus	TUV
PTS060315V004	15	1	0.04	0.12	0.5	0.2	1.0	1.5	40	√	√
PTS060315V005	15	1	0.05	0.15	0.5	0.25	1.0	1.0	40	√	√
PTS060315V010	15	3	0.10	0.25	0.5	0.5	1.0	0.5	6	√	√
PTS06039V016	9	4	0.16	0.40	0.5	1.0	1.0	0.4	5	√	√
PTS06039V020	9	4	0.20	0.50	0.5	1.0	0.6	0.3	4	√	√
PTS06036V035	6	8	0.35	0.75	0.5	8.0	0.1	0.09	1.5	√	√

- V_{max}: Maximum continuous voltage the device can withstand without damage at rated current
- I_{max}: Maximum fault current the device can withstand without damage at rated voltage
- I_{hold}: Maximum current the device will pass without interruption at +23 °C still air
- I_{trip}: Minimum current that will transition the device from low resistance to high resistance at +23 °C still air
- P_d: Power dissipated from the device when in tripped state at +23 °C still air

- R_i: Minimum resistance of the device at +23 °C
R₁: Maximum resistance of the device one hour after tripping at +23 °C

Dimensions—mm

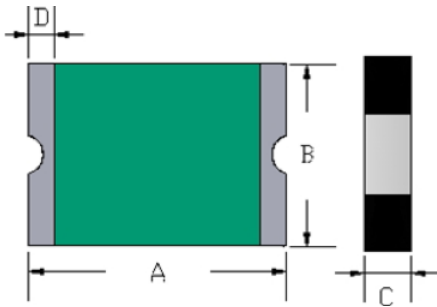

No marking

Recommended pad layout

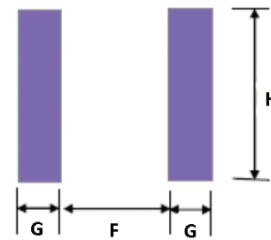

Part number	A typ	A max	B typ	B max	C typ	C max	D min	F	G	H
PTS060315V004	1.65	1.80	0.80	1.00	0.56	0.80	0.15	0.8	0.6	0.8
PTS060315V005	1.65	1.80	0.80	1.00	0.56	0.80	0.15	0.8	0.6	0.8
PTS060315V010	1.65	1.80	0.80	1.00	0.53	0.80	0.15	0.8	0.6	0.8
PTS06039V016	1.65	1.80	0.80	1.00	0.50	0.80	0.15	0.8	0.6	0.8
PTS06039V020	1.65	1.80	0.90	1.00	0.45	0.80	0.15	0.8	0.6	0.8
PTS06036V035	1.65	1.80	0.90	1.00	0.70	0.80	0.15	0.8	0.6	0.8

General specifications

Operating temperature: -40 °C to + 85 °C (with derating)

Storage temperature: -10 °C to + 40 °C

Storage relative humidity: ≤70%

Storage condition: Keep away from corrosive atmosphere and sunlight

Passive aging: IEC60738-1, +85 °C, 1000 hours, ≤20%

Humidity aging: +85 °C, 85% RH, 100 hours, ≤20%

Thermal shock: IEC60738-1, +85 °C/ -40 °C, 20 cycles, ≤50%

Trip cycle life: UL1434, Vmax, Imax, 100 cycles, no arcing or burning

Trip endurance: UL1434, Vmax, Itrip ≤ I ≤ Imax, 2 hours, no arcing or burning

MSL test: J-STD-020, MSL=1, pass and no visible damage

Thermal derating curve PTS0603

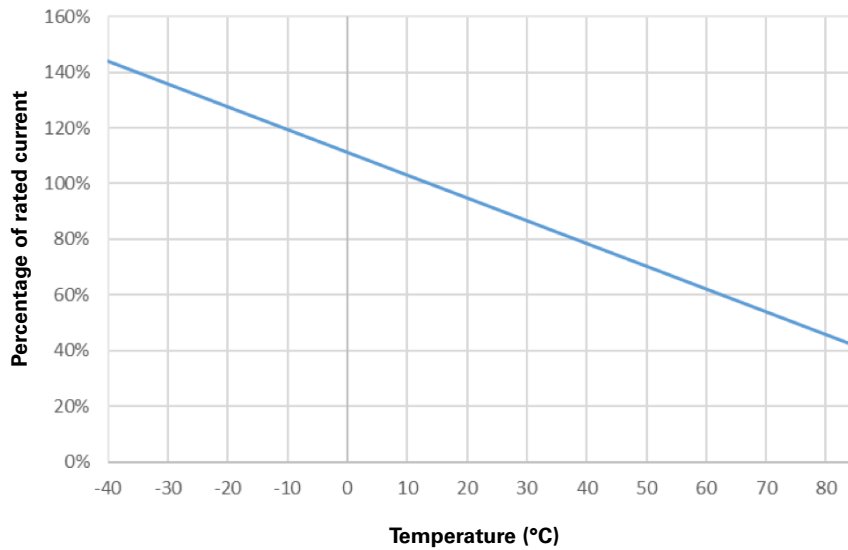

Packaging information

PTS0603xxV004-xxV020

Supplied in tape and reel packaging, 5000 parts per 7.0" (178 mm) diameter reel (EIA-481 compliant)

PTS06036V035

Supplied in tape and reel packaging, 5000 parts per 7.0" (178 mm) diameter reel (EIA-481 compliant)

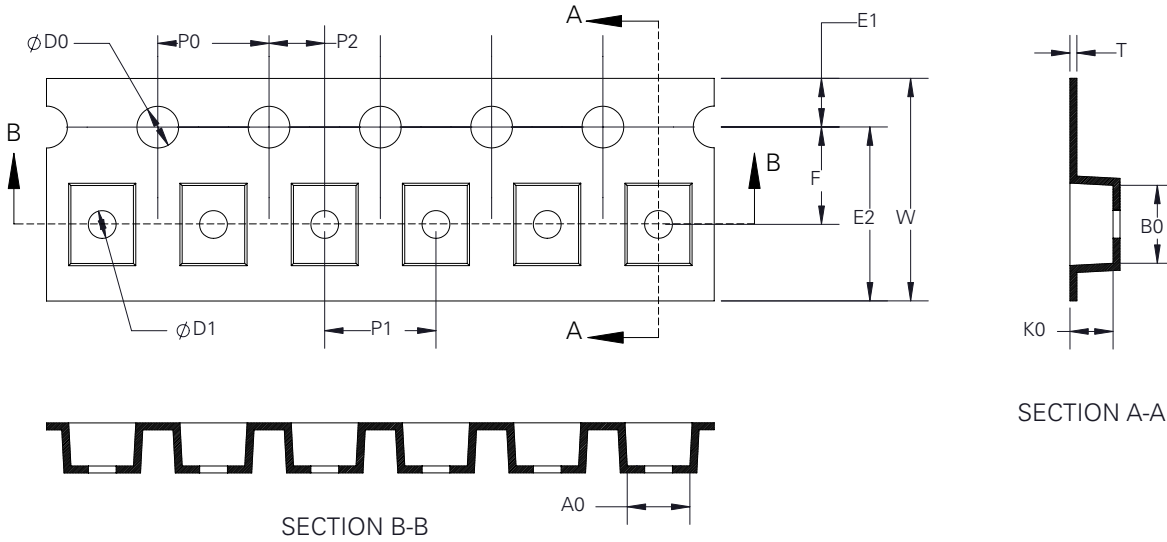

PTS0603xxV004-xxV020

W	F	E1	E2	P0	P1	P2	D0	D1	A0	B0	K0	T
8.00 ± 0.30	3.50 ± 0.10	1.75 ± 0.10	-	4.00 ± 0.10	4.00 ± 0.10	2.00 ± 0.05	1.50 + 0.10/-0	-	1.10 ± 0.10	1.85 ± 0.10	0.60 ± 0.10	0.20 ± 0.05

PTS06036V035

W	F	E1	E2	P0	P1	P2	D0	D1	A0	B0	K0	T
8.00 ± 0.30	3.50 ± 0.10	1.75 ± 0.10	-	4.00 ± 0.10	4.00 ± 0.10	2.00 ± 0.05	1.50 + 0.10/-0	-	1.10 ± 0.10	1.85 ± 0.10	0.85 ± 0.10	0.20 ± 0.05

Wave solder profile

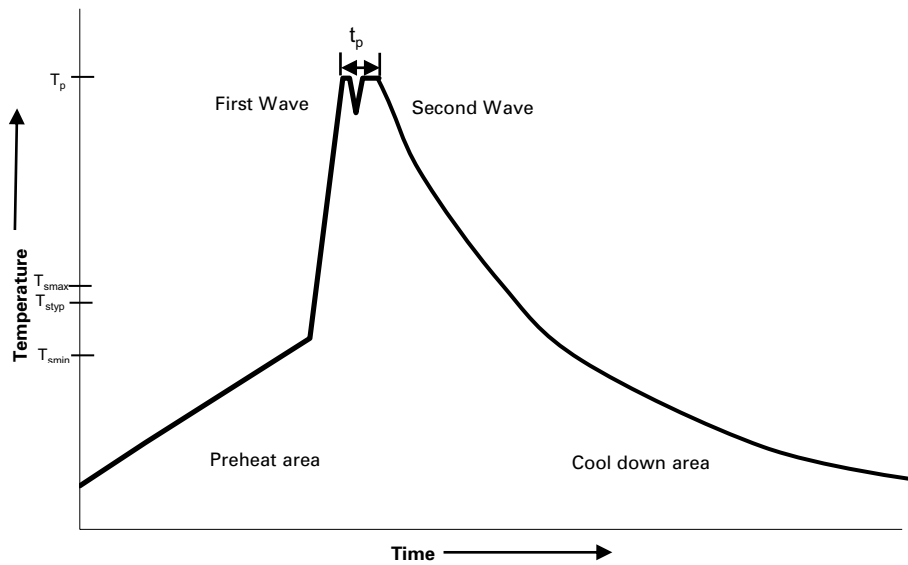

Reference EN 61760-1:2006

Profile feature	Standard SnPb solder	Lead (Pb) free solder
Preheat	• Temperature min. (T_{smin})	100 °C
	• Temperature typ. (T_{styp})	120 °C
	• Temperature max. (T_{smax})	130 °C
	• Time (T_{smin} to T_{smax}) (t_s)	70 seconds
Δ preheat to max Temperature	150 °C max.	150 °C max.
Peak temperature (T_p)*	235 °C – 260 °C	250 °C – 260 °C
Time at peak temperature (t_p)	10 seconds max 5 seconds max each wave	10 seconds max 5 seconds max each wave
Ramp-down rate	~ 2 K/s min ~3.5 K/s typ ~5 K/s max	~ 2 K/s min ~3.5 K/s typ ~5 K/s max
Time 25°C to 25°C	4 minutes	4 minutes

Manual solder

+350 °C (4-5 seconds by soldering iron), generally manual/hand soldering is not recommended