

# PTSLR1206

## Low resistance SMD PTC fuses



### Product features

- Positive temperature coefficient (PTC)
- Surface mount resettable fuse
- Low resistance
- Compact 1206 (3216 metric) footprint
- Voltage rating 6 V
- Current rating from 0.75 A to 7.0 A
- Fast time-to-trip

### Applications

- Data ports
- Micromotors and fans
- Low voltage test and measurement
- Low voltage hand held equipment
- PC-based medical equipment
- USB protection
- Secondary Li-ion battery protection
- Game consoles, set top boxes
- Battery charging & charging connections

### Agency information

- cURus Recognized file no. E343021
- TUV: File R 50455924, R 50506608



### Environmental compliance



### Part number system/ordering:

#### PTSLR1206V075

- PT= PTC resettable fuse
- S= Surface mount
- LR = Low resistance
- 1206= Dimension code
- 6V= Maximum voltage
- 550= Ihold current rating (550= 5.5 A)

Product specifications

Part number	V <sub>max</sub> <sup>1</sup>	I <sub>max</sub> <sup>2</sup>	I <sub>hold</sub> <sup>3</sup>	I <sub>trip</sub> <sup>4</sup>	P <sub>d</sub> <sup>5</sup>	Time-to-trip (maximum)		Resistance <sup>6</sup>		Part marking	Safety approvals	
	(V <sub>dc</sub> )	(A)	(A)	(A)	typical (W)	(A)	(seconds)	Initial (R <sub>i</sub> ) minimum (Ω)	Post trip (R <sub>1</sub> ) maximum (Ω)		cURus	TÜV
PTSLR12066V075	6	50	0.75	1.5	0.8	8	0.3	0.017	0.18	La	√	√
PTSLR12066V110	6	50	1.1	2.2	0.8	8	0.3	0.015	0.13	Lb	√	√
PTSLR12066V150	6	50	1.5	3.0	0.8	8	0.3	0.010	0.08	Lc	√	√
PTSLR12066V175	6	50	1.75	3.5	0.8	8	0.4	0.005	0.045	L3	√	√
PTSLR12066V200	6	50	2.0	4.0	0.8	8	0.5	0.005	0.04	L7	√	√
PTSLR12066V260	6	50	2.6	5.0	0.8	8	4	0.003	0.03	L8	√	√
PTSLR12066V300	6	50	3.0	6.0	0.8	8	4	0.003	0.026	L9	√	√
PTSLR12066V350	6	50	3.5	7.0	0.8	8	5	0.003	0.018	L1	√	√
PTSLR12066V380	6	50	3.8	8.0	0.8	8	5	0.002	0.014	L2	√	√
PTSLR12066V400	6	50	4.0	8.0	0.8	20	2	0.001	0.014	L5	√	√
PTSLR12066V450	6	50	4.5	9.0	0.8	22	2	0.001	0.014	L6	√	√
PTSLR12066V500	6	50	5.0	10.0	0.8	25	2	0.001	0.013	Le	√	√
PTSLR12066V550	6	50	5.5	11.0	1.5	27.5	5	0.001	0.01	L5	√	√
PTSLR12066V600	6	50	6.0	12.0	1.5	30	5	0.001	0.01	L7	√	√
PTSLR12066V650	6	50	6.5	13.0	1.5	32.5	5	0.001	0.009	L65	√	√
PTSLR12066V700	6	50	7.0	14.0	1.5	35	5	0.001	0.008	L70	√	√

- V<sub>max</sub>: Maximum continuous voltage the device can withstand without damage at rated current
- I<sub>max</sub>: Maximum fault current the device can withstand without damage at rated voltage
- I<sub>hold</sub>: Maximum current the device will pass without interruption at +23 °C still air unless otherwise specified
- I<sub>trip</sub>: Minimum current that will transition the device from low resistance to high resistance at +23 °C still air, unless otherwise specified

- P<sub>d</sub>: Power dissipated from the device when in tripped state at +23 °C still air, unless otherwise specified
- R<sub>i</sub>: Minimum resistance of the device prior to tripping at +23 °C  
R<sub>1</sub>: Maximum resistance of the device one hour after tripping at +23 °C

Part number	A min	A max	B min	B max	C min	C max	D min	D max	E min	E max	F	G	H
PTSLR12066V075	3.0	3.5	1.5	1.8	0.4	0.7	0.125	0.75	0.08	0.45	2.0	1.0	1.9
PTSLR12066V110	3.0	3.5	1.5	1.8	0.4	0.7	0.125	0.75	0.08	0.45	2.0	1.0	1.9
PTSLR12066V150	3.0	3.5	1.5	1.8	0.4	0.7	0.125	0.75	0.08	0.45	2.0	1.0	1.9
PTSLR12066V175	3.0	3.5	1.5	1.8	0.6	1.2	0.125	0.75	0.08	0.45	2.0	1.0	1.9
PTSLR12066V200	3.0	3.5	1.5	1.8	0.6	1.2	0.125	0.75	0.08	0.45	2.0	1.0	1.9
PTSLR12066V260	3.0	3.5	1.5	1.8	0.6	1.2	0.125	0.75	0.08	0.45	2.0	1.0	1.9
PTSLR12066V300	3.0	3.5	1.5	1.8	0.6	1.2	0.125	0.75	0.08	0.45	2.0	1.0	1.9
PTSLR12066V350	3.0	3.5	1.5	1.8	0.6	1.2	0.125	0.75	0.08	0.45	2.0	1.0	1.9
PTSLR12066V380	3.0	3.5	1.5	1.8	0.6	1.2	0.125	0.75	0.08	0.45	2.0	1.0	1.9
PTSLR12066V400	3.0	3.5	1.5	1.8	0.6	1.2	0.125	0.75	0.08	0.45	2.0	1.0	1.9
PTSLR12066V450	3.0	3.5	1.5	1.8	0.6	1.2	0.125	0.75	0.08	0.45	2.0	1.0	1.9
PTSLR12066V500	3.0	3.5	1.5	1.8	0.6	1.2	0.125	0.75	0.08	0.45	2.0	1.0	1.9
PTSLR12066V550		3.5		1.8		1	0.25		0.1		1.8	1.0	1.8
PTSLR12066V600		3.5		1.8		1	0.25		0.1		1.8	1.0	1.8
PTSLR12066V650		3.5		1.8		1.3	0.25		0.1		1.8	1.0	1.8
PTSLR12066V700		3.5		1.8		1.3	0.25		0.1		1.8	1.0	1.8

**Dimensions—mm**

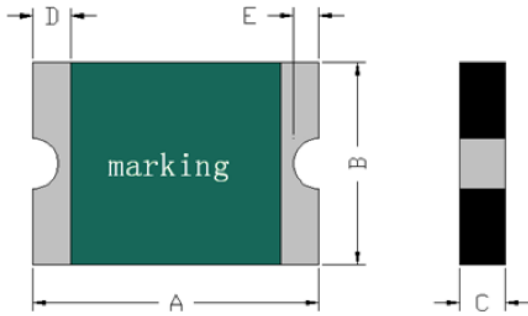

**Recommended pad layout**

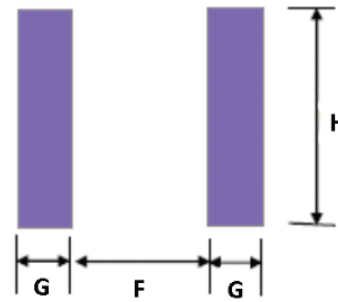

**Thermal derating curve  
PTSLR12066V075-V500**

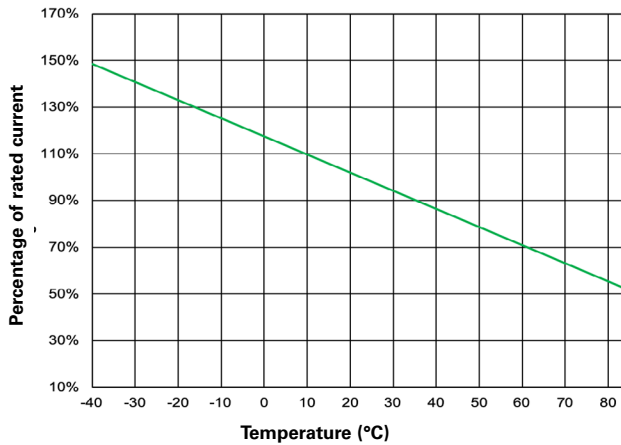

**Thermal derating curve  
PTSLR12066V550-V700**

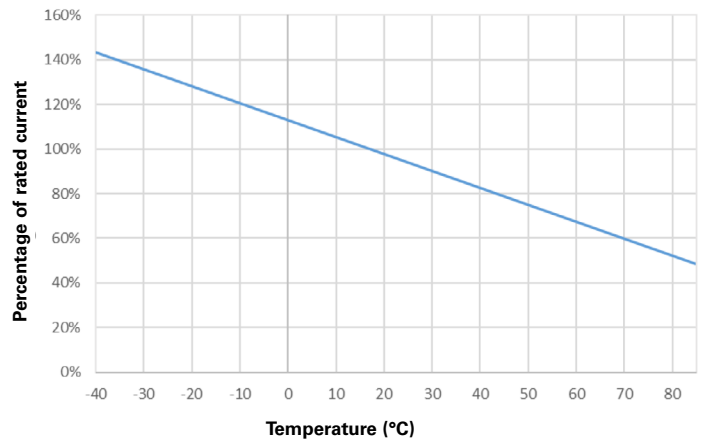

**General specifications (PTSLR12066V075-V500)**

Operating temperature: -40 °C to + 85 °C (with derating)
Storage temperature: -10 °C to + 40 °C
Storage relative humidity: ≤75%
Storage condition: Keep away from corrosive atmosphere and sunlight
Passive aging: IEC60738-1, +85 ± 5 °C, 1000 ± 24 hours
Humidity aging: +85 °C, 80 to 85% relative humidity, 100 ± 5 hours
Rapid change of temperature: IEC60738-1, +85 ± 5/-40 ± 5 °C, 20 cycles, 30 minutes
Overload endurance: UL1434, Vmax, 120% Imax, 50 cycles Vmax, 300% Itrip, 6000 cycles
Trip endurance: UL1434, Vmax, Itrip -I Imax, 1000 ± 24 hours
Solderability: IEC60068-2-58, +245 ± 5 °C, 3 ± 0.3 seconds
Moisture sensitivity test: J-STD-020, MSL=2a

**General specifications (PTSLR12066V550-V700)**

Operating temperature: -40 °C to + 85 °C (with derating)
Storage temperature: -10 °C to + 40 °C
Storage relative humidity: ≤70%
Storage condition: Keep away from corrosive atmosphere and sunlight
Passive aging: IEC60738-1, +60 °C/90% RH, 168 hours, ≤3*R1max
Humidity aging: +85 °C, 85% RH, 96 hours, ≤3*R1max
Thermal shock: IEC60738-1, +85 °C/ -40 °C, 20 cycles, ≤3*R1max
Trip cycle life: UL1434, Vmax, Imax, 100 cycles, no arcing or burning
Trip endurance: UL1434, Vmax, Itrip ≤ I Imax, 2 hours, no arcing or burning
Solvent resistance: Freon, Trichloroethane, Hydrocarbons: no change
MSL test: J-STD-020, MSL=2, pass and no visible damage

**Packaging information**  
**PTSLR12066V075-500**

PTSLR12066V075, PTSLR12066V110, PTSLR12066V150,  
Supplied in tape and reel packaging, 5000 parts per 7.0" (178 mm) diameter reel (EIA-481 compliant)

PTSLR12066V175, PTSLR12066V200, PTSLR12066V260, PTSLR12066V300, PTSLR12066V350, PTSLR12066V380,  
PTSLR12066V400, PTSLR12066V450, PTSLR12066V500  
Supplied in tape and reel packaging, 2500 parts per 7.0" (178 mm) diameter reel (EIA-481 compliant)

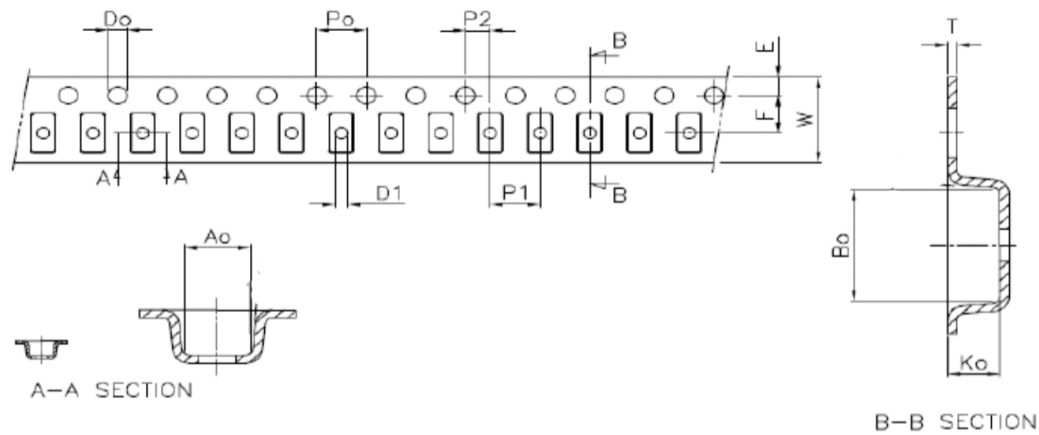

PTSLR12066V075, PTSLR12066V110, PTSLR12066V150

$A_0$	$B_0$	$K_0$	$P_0$	$P_1$	$P_2$	T	E	F	$D_0$	$D_1$	W	$10P_0$
$\pm 0.10$	$\pm 0.10$	$\pm 0.05$	$\pm 0.10$	$\pm 0.10$	$\pm 0.10$	$\pm 0.05$	$\pm 0.10$	$\pm 0.10$	$\pm 0.05$	min	$\pm 0.30$	$\pm 0.20$
1.85	3.45	0.85	4.0	4.0	2.0	0.23	1.75	3.50	1.55	1.0	8.0	40

PTSLR12066V175, PTSLR12066V200, PTSLR12066V260, PTSLR12066V300, PTSLR12066V350, PTSLR12066V380, PTSLR12066V400,  
PTSLR12066V450, PTSLR12066V500

$A_0$	$B_0$	$K_0$	$P_0$	$P_1$	$P_2$	T	E	F	$D_0$	$D_1$	W	$10P_0$
$\pm 0.10$	$\pm 0.10$	$\pm 0.05$	$\pm 0.10$	$\pm 0.10$	$\pm 0.10$	$\pm 0.05$	$\pm 0.10$	$\pm 0.10$	$\pm 0.05$	min	$\pm 0.30$	$\pm 0.20$
1.95	3.55	1.40	4.0	4.0	2.0	0.23	1.75	3.50	1.55	1.0	8.0	40

**Packaging information**  
**PTSLR12066V550-700**

PTSLR12066V550, PTSLR12066V600,  
 Supplied in tape and reel packaging, 4000 parts per 7.0" (178 mm) diameter reel (EIA-481 compliant)

PTSLR12066V650, PTSLR12066V700,  
 Supplied in tape and reel packaging, 3500 parts per 7.0" (178 mm) diameter reel (EIA-481 compliant)

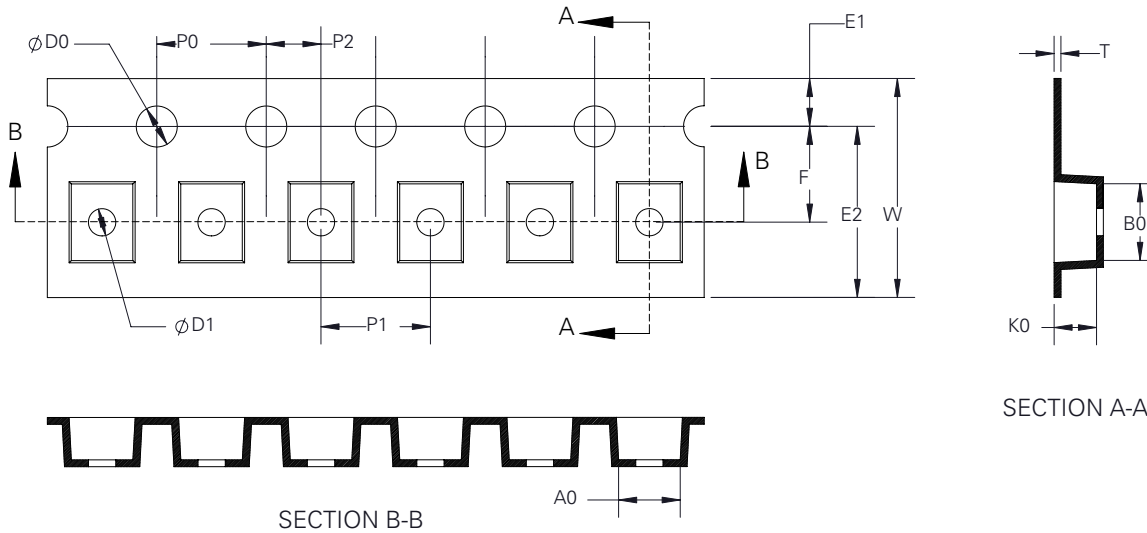

SECTION A-A

SECTION B-B

W	F	E1	E2	P0	P1	P2	D0	D1	A0	B0	K0	T
8.00 ± 0.30	3.50 ± 0.10	1.75 ± 0.10	-	4.00 ± 0.10	4.00 ± 0.10	2.00 ± 0.05	1.55 + 0.10/-0	-	1.77 ± 0.10	3.40 ± 0.10	1.04 ± 0.10	0.22 ± 0.05

### Wave solder profile

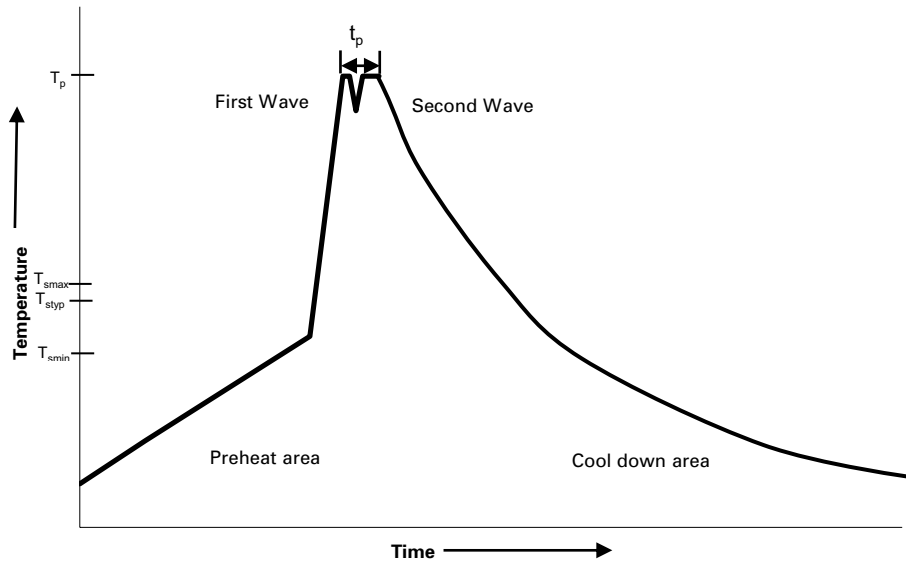

### Reference EN 61760-1:2006

Profile feature	Standard SnPb solder	Lead (Pb) free solder
Preheat	• Temperature min. ( $T_{smin}$ )	100 °C
	• Temperature typ. ( $T_{styp}$ )	120 °C
	• Temperature max. ( $T_{smax}$ )	130 °C
	• Time ( $T_{smin}$ to $T_{smax}$ ) ( $t_s$ )	70 seconds
$\Delta$ preheat to max Temperature	150 °C max.	150 °C max.
Peak temperature ( $T_p$ )*	235 °C – 260 °C	250 °C – 260 °C
Time at peak temperature ( $t_p$ )	10 seconds max 5 seconds max each wave	10 seconds max 5 seconds max each wave
Ramp-down rate	~ 2 K/s min ~3.5 K/s typ ~5 K/s max	~ 2 K/s min ~3.5 K/s typ ~5 K/s max
Time 25°C to 25°C	4 minutes	4 minutes

### Manual solder

+350 °C (4-5 seconds by soldering iron), generally manual/hand soldering is not recommended