

PTVA092407NF

Thermally-Enhanced High Power RF LDMOS FET 240 W, 48 V, 869 – 960 MHz

Description

The PTVA092407NF is a 240-watt LDMOS FET manufactured with Wolfspeed's 48-V LDMOS process. It is designed for use in multi-standard cellular power amplifier applications. It features a single ended design and input and output matching that allow for use from 869 MHz to 960 MHz. Manufactured with Wolfspeed's advanced LDMOS process, this device provides excellent thermal performance and superior reliability.



PTVA092407NF
Package PG-HBSOF-4-2

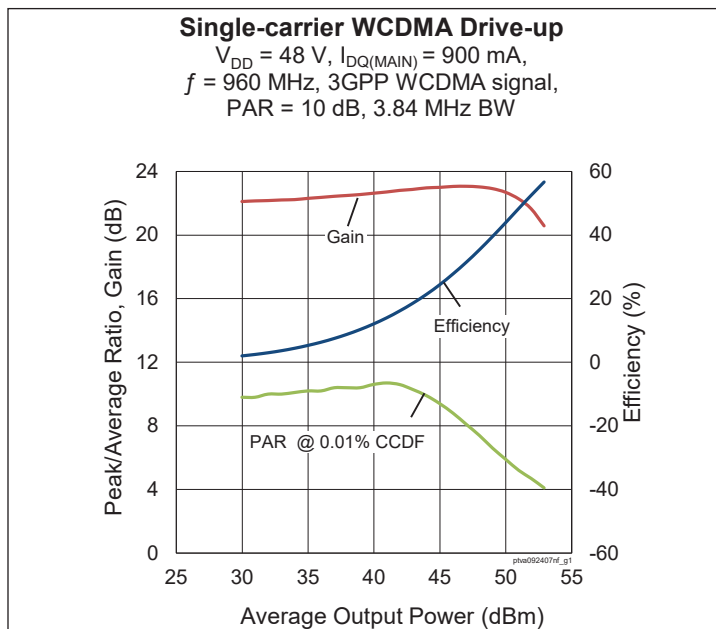

Features

- Broadband internal input and output matching
- Typical CW performance, 960 MHz, 48 V, 10 μs pulse width, 10% duty cycle, single side
 - Output power at $P_{1dB} = 240\text{ W}$
 - Output power at $P_{3dB} = 287\text{ W}$
 - Gain = 20 dB
 - Efficiency = 62%
- Capable of handling 10:1 VSWR @ 48 V, 80 W CW output power
- Integrated ESD protection
- Human Body Model class 2 (per ANSI/ESDA/ JEDEC JS-001)
- Low thermal resistance
- Pb-free and RoHS compliant

RF Characteristics

Single-carrier WCDMA Specifications (tested in Wolfspeed production test fixture)

$V_{DD} = 48\text{ V}$, $I_{DQ} = 900\text{ mA}$, $P_{OUT} = 80\text{ W}$ avg, $f = 960\text{ MHz}$, 3GPP signal, channel bandwidth = 3.84 MHz, peak/average = 10 dB @ 0.01% CCDF

Characteristic	Symbol	Min	Typ	Max	Unit
Linear Gain	G_{ps}	21.3	22.5	—	dB
Drain Efficiency	η_D	38	40	—	%
Adjacent Channel Power Ratio	ACPR	—	-30	-28.5	dBc
Output PAR @ 0.01% CCDF	OPAR	5.7	6.2	—	dB

All published data at $T_{CASE} = 25^\circ\text{C}$ unless otherwise indicated

ESD: Electrostatic discharge sensitive device—observe handling precautions!

DC Characteristics

Characteristic	Conditions	Symbol	Min	Typ	Max	Unit
Drain-Source Breakdown Voltage	$V_{GS} = 0\text{ V}, I_{DS} = 10\text{ mA}$	$V_{(BR)DSS}$	105	—	—	V
Drain Leakage Current	$V_{DS} = 50\text{ V}, V_{GS} = 0\text{ V}$	I_{DSS}	—	—	1	μA
	$V_{DS} = 105\text{ V}, V_{GS} = 0\text{ V}$	I_{DSS}	—	—	10	μA
Gate Leakage Current	$V_{GS} = 10\text{ V}, V_{DS} = 0\text{ V}$	I_{GSS}	—	—	1	μA
On-State Resistance (Main)	$V_{GS} = 10\text{ V}, V_{DS} = 0.1\text{ V}$	$R_{DS(on)}$	—	0.13	—	Ω
Operating Gate Voltage (Main)	$V_{DS} = 48\text{ V}, I_{DQ} = 900\text{ mA}$	V_{GS}	3.3	3.7	4.1	V

Maximum Ratings

Parameter	Symbol	Value	Unit
Drain-Source Voltage	V_{DSS}	105	V
Gate-Source Voltage	V_{GS}	-6 to +12	V
Operating Voltage	V_{DD}	0 to +55	V
Junction Temperature	T_J	225	$^{\circ}\text{C}$
Storage Temperature Range	T_{STG}	-65 to +150	$^{\circ}\text{C}$

1. Operation above the maximum values listed here may cause permanent damage. Maximum ratings are absolute ratings; exceeding only one of these values may cause irreversible damage to the component. Exposure to absolute maximum rating conditions for extended periods may affect device reliability. For reliable continuous operation, the device should be operated within the operating voltage range (V_{DD}) specified above.

2. Parameters values can be affected by end application and product usage. Values may change over time.

Thermal Characteristics

Parameter	Symbol	Value	Unit
Thermal Resistance (Main, $T_{CASE} = 70^{\circ}\text{C}, 240\text{ W CW}$)	$R_{\theta JC}$	0.29	$^{\circ}\text{C/W}$

Moisture Sensitivity Level

Level	Test Signal	Package Temperature	Unit
3	IPC/JEDEC J-STD-020	260	$^{\circ}\text{C}$

Ordering Information

Type and Version	Order Code	Package Description	Shipping
PTVA092407NF V2 R5	PTVA092407NF-V2-R5	PG-HBSOF-4-2, plastic package	Tape & Reel, 500 pcs

Typical RF Performance (data taken in production test fixture)

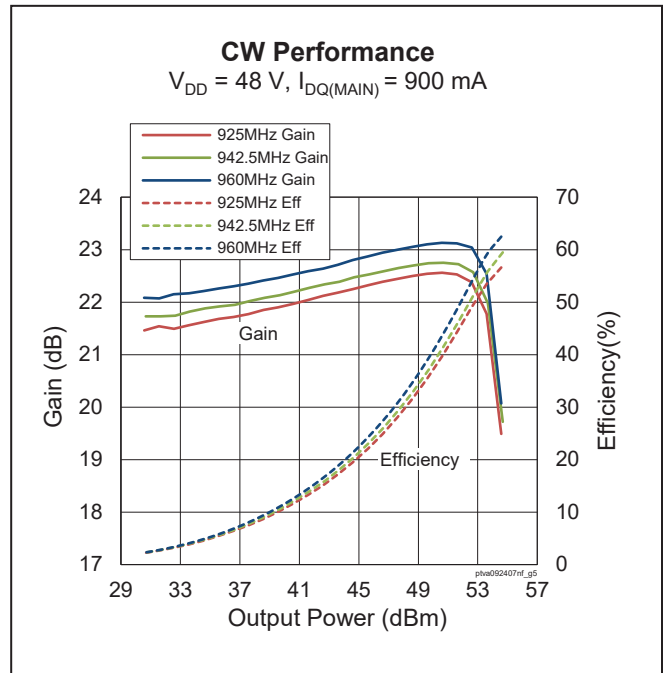
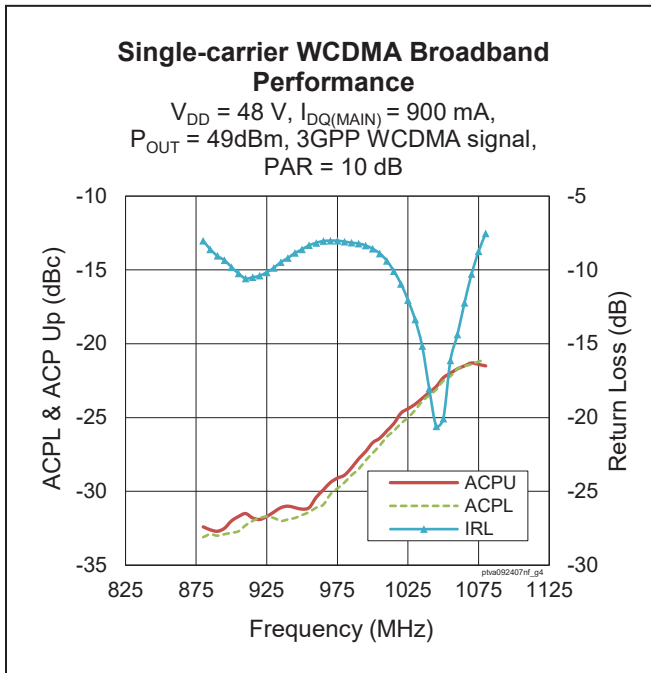
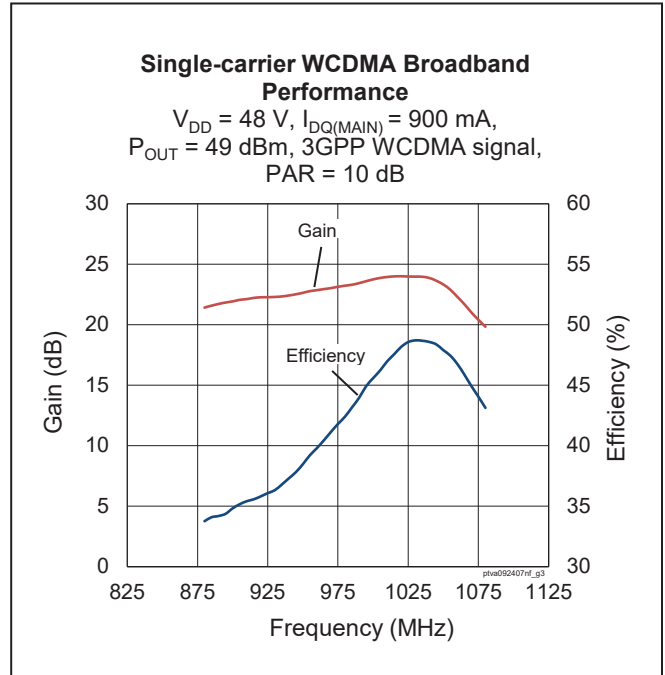
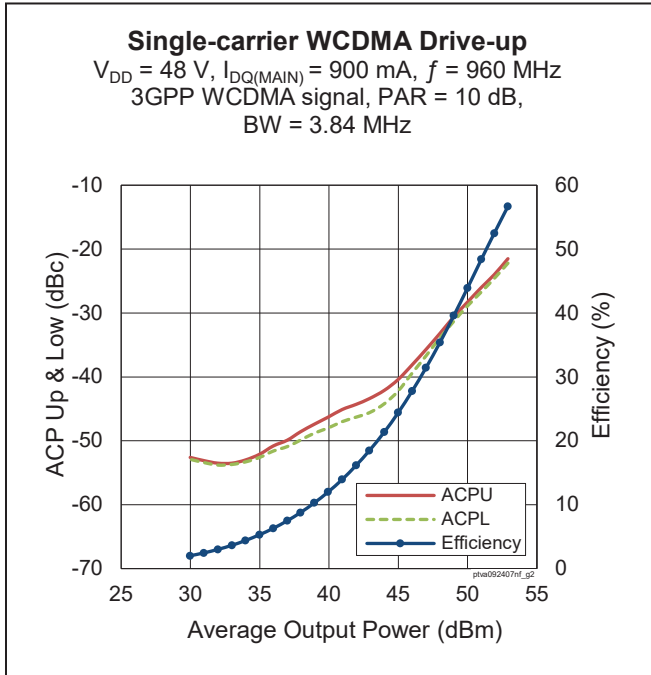

Typical RF Performance (cont.)

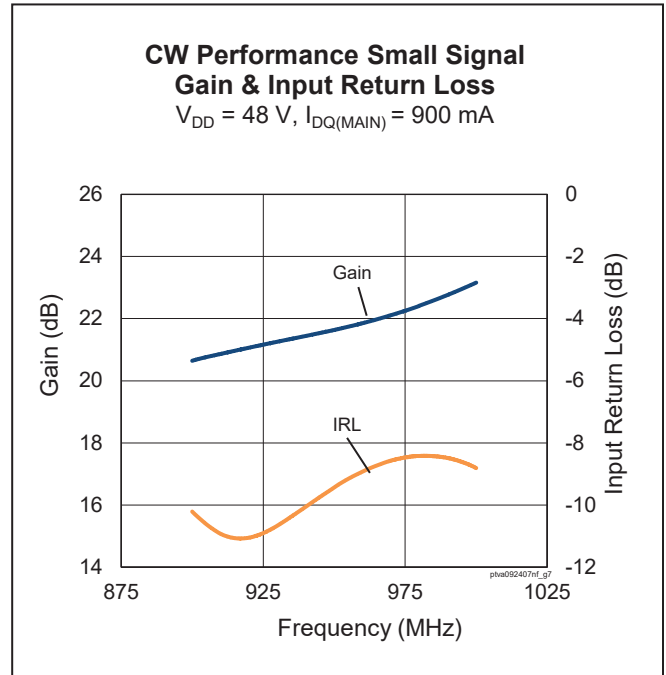
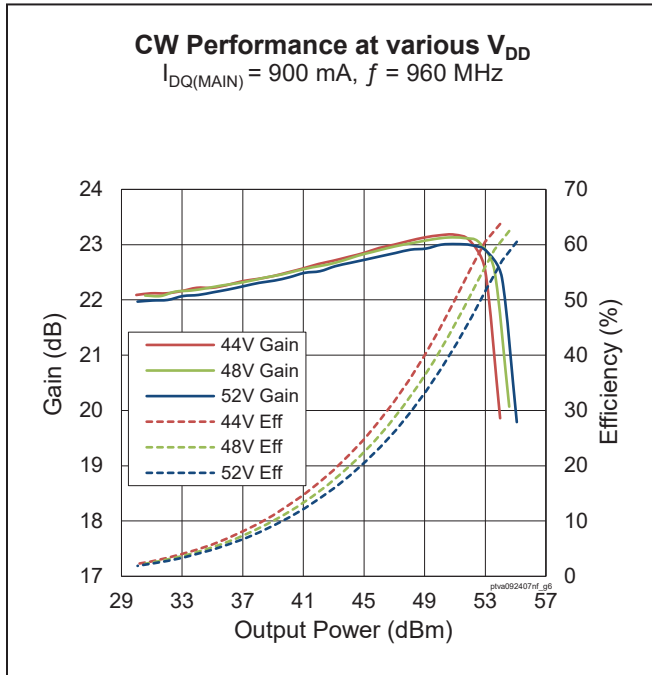

Load Pull Performance

Each Side Load Pull Performance – Pulsed CW signal: 10 μs, 10% duty cycle, 48 V, I_{DQ} = 480 mA

		P _{1dB}									
		Max Output Power					Max Drain Efficiency				
Freq [MHz]	Z _s [Ω]	Z _l [Ω]	Gain [dB]	P _{1dB} [dBm]	P _{1dB} [W]	η _D [%]	Z _l [Ω]	Gain [dB]	P _{1dB} [dBm]	P _{1dB} [W]	η _D [%]
869	0.69-j3.06	1.52-j0.62	20.83	55.70	371.54	57.6	2.72+j1.29	23.07	53.51	224.39	71.3
925	1.29-j3.32	1.46-j0.56	21.35	55.55	354.81	60.4	2.24+j1.18	23.44	53.27	212.32	70.5
960	2.45-j3.23	1.31-j0.55	21.52	55.51	355.63	59.9	2.01+j0.7	23.39	53.66	232.27	71.7

		P _{3dB}									
		Max Output Power					Max Drain Efficiency				
Freq [MHz]	Z _s [Ω]	Z _l [Ω]	Gain [dB]	P _{3dB} [dBm]	P _{3dB} [W]	η _D [%]	Z _l [Ω]	Gain [dB]	P _{3dB} [dBm]	P _{3dB} [W]	η _D [%]
869	0.69-j3.06	1.55-j0.78	18.81	56.40	436.52	60.0	2.81+j1.47	21.17	53.84	242.1	71.9
925	1.29-j3.32	1.58-j0.7	19.43	56.30	426.58	63.2	2.27+j1.17	21.46	53.90	245.47	72.6
960	2.45-j3.23	1.41-j0.54	19.72	56.17	414	64.7	1.76+j0.92	21.5	53.87	243.78	72.7

Reference Circuit, 869 – 960 MHz

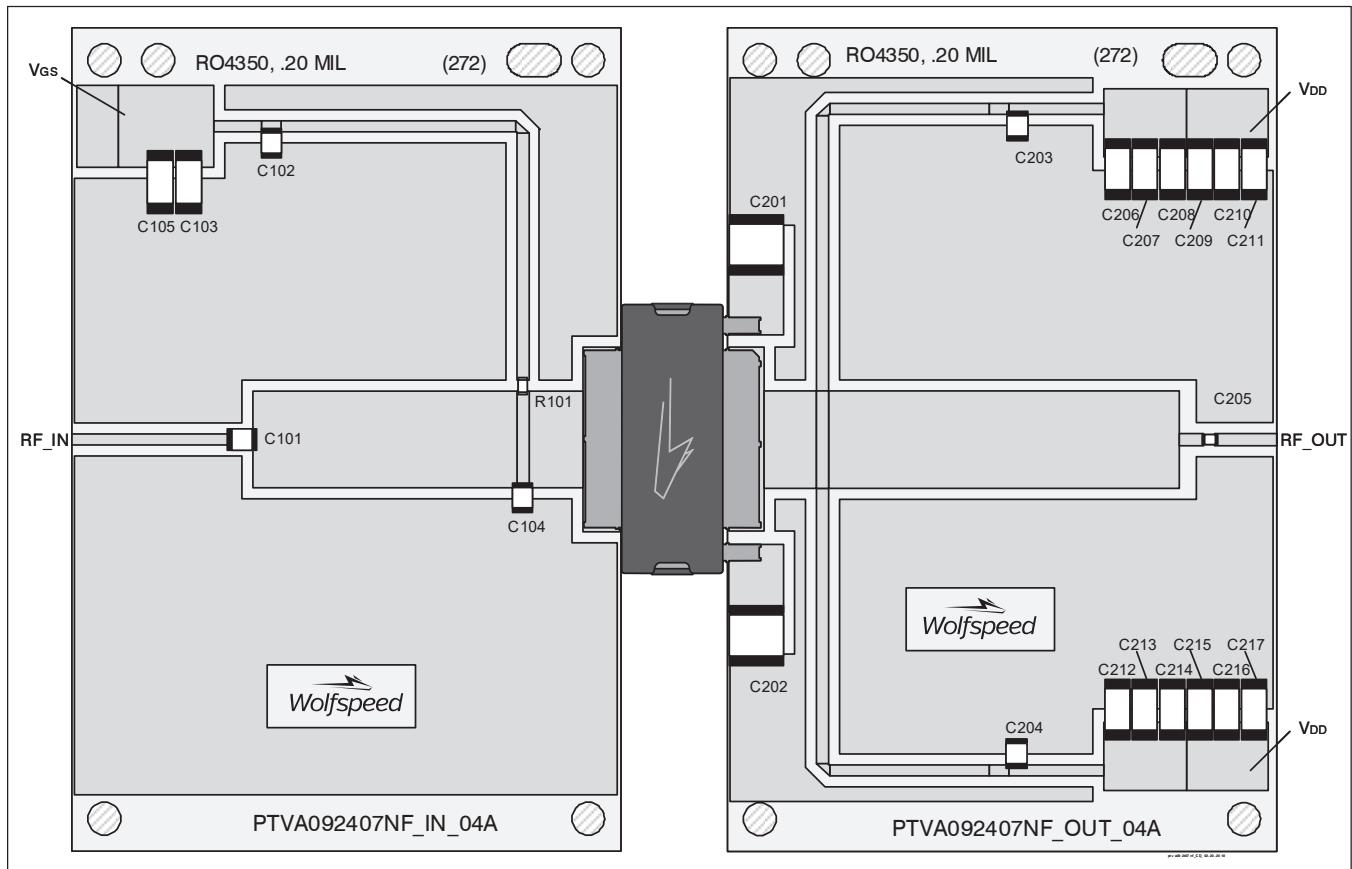

Reference circuit assembly diagram (not to scale)

Reference Circuit Assembly

DUT	PTVA092407NF-V2
Test Fixture Part No.	LTN/PTVA092407NF-V2
PCB	Rogers 4350, 0.508 mm [0.020"] thick, 2 oz. copper, $\epsilon_r = 3.66$, $f = 869 - 960$ MHz
Find Gerber files for this test fixture on the Wolfspeed Web site at www.wolfspeed.com/RF	

Components Information

Component	Description	Manufacturer	P/N
Input			
C101	Capacitor, 47 pF	ATC	ATC100B470KW500XT
C102	Capacitor, 75 pF	ATC	ATC100B750KW500XT
C103, C105	Capacitor, 10 μ F, 100 V	TDK Corporation	C5750X7S2A106M230KB
C104	Capacitor, 3.6 pF	ATC	ATC100B3R6CW500XT
R101	Resistor, 10 ohms	Panasonic Electronic Components	ERJ-8GEYJ100V
Output			
C201, C202, C206, C207, C208, C209, C210, C211, C212, C213, C214, C215, C216, C217	Capacitor, 10 μ F, 100 V	TDK Corporation	C5750X7S2A106M230KB
C203, C204	Capacitor, 75 pF	ATC	ATC100B750KW500XT
C205	Capacitor, 10 pF	ATC	ATC100A101JW150XT



Pinout Diagram (top view)

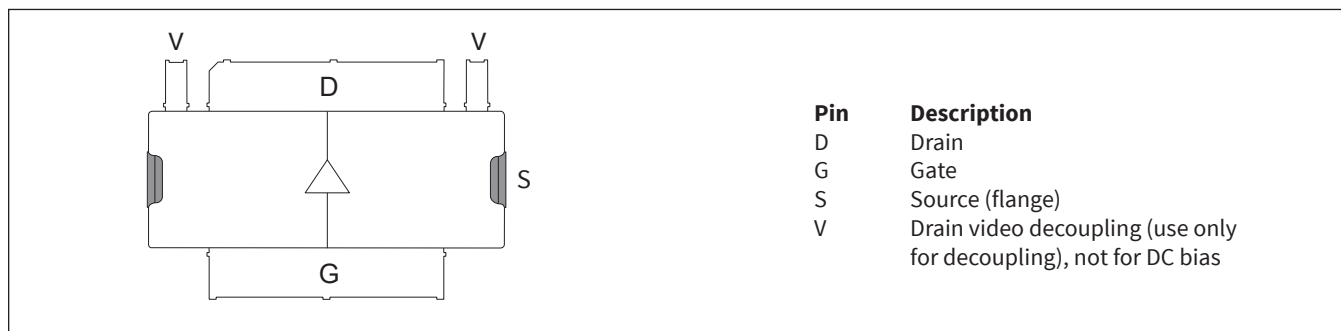

Package Outline Specifications

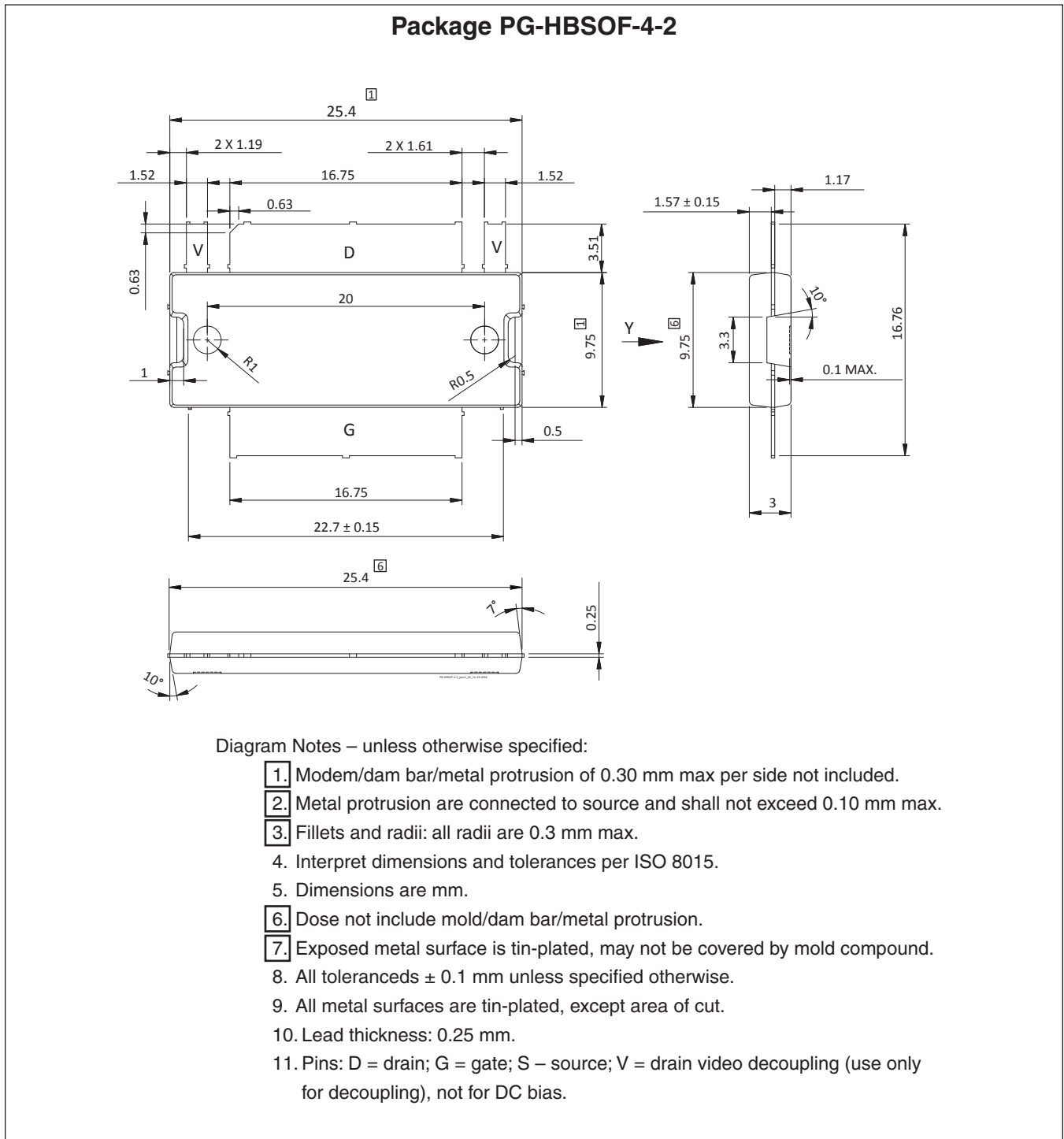

Package Outline Specifications (cont.)

Package PG-HBSOF-4-2

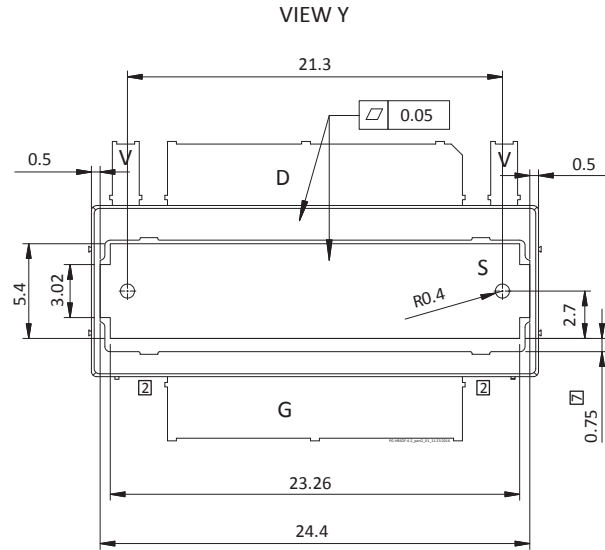

Diagram Notes – unless otherwise specified:

1. Mold/dam bar/metal protrusion of 0.30 mm max per side not included.
2. Metal protrusion are connected to source and shall not exceed 0.10 mm max.
3. Fillets and radii: all radii are 0.3 mm max.
4. Interpret dimensions and tolerances per ISO 8015.
5. Dimensions are mm.
6. Dose not include mold/dam bar/metal protrusion.
7. Exposed metal surface is tin-plated, may not be covered by mold compound.
8. All toleranceds ± 0.1 mm unless specified otherwise.
9. All metal surfaces are tin-plated, except area of cut.
10. Lead thickness: 0.25 mm.
11. Pins: D = drain; G = gate; S = source; V = drain video decoupling (use only for decoupling), not for DC bias.