

PTVA120252MT

Thermally-Enhanced High Power RF LDMOS FET 25 W, 48 V, 500 – 1400 MHz

Description

The PTVA120252MT LDMOS FET is a 25-watt LDMOS FET designed for use in power amplifier applications in the 500 MHz to 1400 MHz frequency band. Features include high gain and a thermally-enhanced, surface-mount package. Manufactured with Wolfspeed's advanced LDMOS process, this device provides excellent thermal performance and superior reliability.

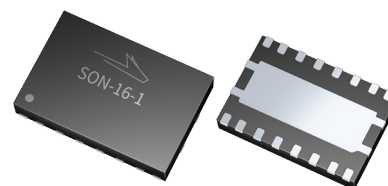

PTVA120252MT
Package PG-SON-16

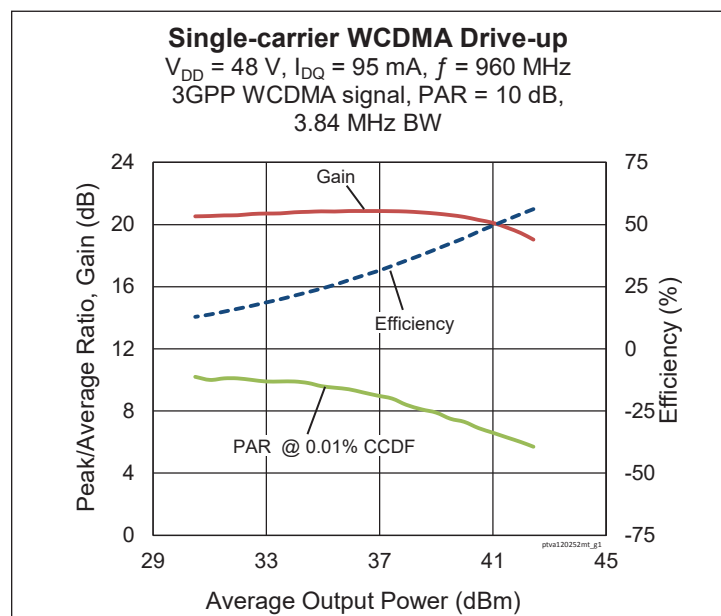

Features

- Unmatched
- Target CW performance 960 MHz, 48 V, combined outputs
 - Output power at $P_{1dB} = 25\text{ W}$
 - Gain = 19.8 dB
 - Efficiency = 64%
- Capable of handling 10:1 VSWR @ 48 V, 20 W CW output power
- Integrated ESD protection
- Human Body Model class 1C (per ANSI/ESDA/ JEDEC JS-001)
- Low thermal resistance
- Pb-free and RoHS compliant

RF Characteristics

Single-carrier WCDMA Specifications (tested in an Wolfspeed production test fixture)

$V_{DD} = 48\text{ V}$, $I_{DQ} = 87\text{ mA}$, $P_{OUT} = 5.5\text{ W}$ average, $f = 960\text{ MHz}$, 3GPP WCDMA signal, 3.84 MHz bandwidth, 10 dB PAR @ 0.01% CCDF

Characteristic	Symbol	Min	Typ	Max	Unit
Linear Gain	G_{ps}	18.5	19.5	—	dB
Drain Efficiency	η_D	28	31.5	—	%
Adjacent Channel Power Ratio	ACPR	—	-33.5	-31	dBc

All published data at $T_{CASE} = 25^\circ\text{C}$ unless otherwise indicated

ESD: Electrostatic discharge sensitive device—observe handling precautions!

DC Characteristics (each side)

Characteristic	Conditions	Symbol	Min	Typ	Max	Unit
Drain-Source Breakdown Voltage	$V_{GS} = 0\text{ V}$, $I_{DS} = 10\text{ mA}$	$V_{(BR)DSS}$	105	—	—	V
Drain Leakage Current	$V_{DS} = 50\text{ V}$, $V_{GS} = 0\text{ V}$	I_{DSS}	—	—	1	μA
	$V_{DS} = 105\text{ V}$, $V_{GS} = 0\text{ V}$	I_{DSS}	—	—	10	μA
Gate Leakage Current	$V_{GS} = 10\text{ V}$, $V_{DS} = 0\text{ V}$	I_{GSS}	—	—	1	μA
On-State Resistance	$V_{GS} = 10\text{ V}$, $V_{DS} = 0.1\text{ V}$	$R_{DS(on)}$	—	2.8	—	Ω
Operating Gate Voltage	$V_{DS} = 48\text{ V}$, $I_{DQ} = 85\text{ mA}$	V_{GS}	3	3.65	4	V

Maximum Ratings

Parameter	Symbol	Value	Unit
Drain-Source Voltage	V_{DSS}	105	V
Gate-Source Voltage	V_{GS}	-6 to +12	V
Operating Voltage	V_{DD}	0 to +55	V
Junction Temperature	T_J	225	$^{\circ}\text{C}$
Storage Temperature Range	T_{STG}	-65 to +150	$^{\circ}\text{C}$

Thermal Characteristics

Parameter	Symbol	Value	Unit
Thermal Resistance ($T_{CASE} = 70^{\circ}\text{C}$, 25 W CW)	$R_{\theta JC}$	2.6	$^{\circ}\text{C/W}$

Ordering Information

Type and Version	Order Code	Package Description	Shipping
PTVA120252MT V1 R1K	PTVA120252MT-V1-R1K	PG-SON-16, plastic package	Tape & Reel, 1000 pcs

Typical RF Performance (data taken in production test fixture)

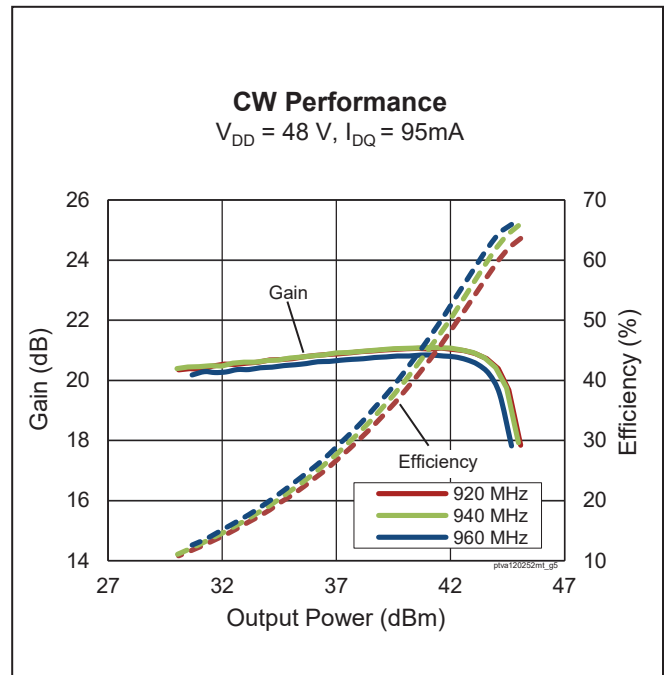
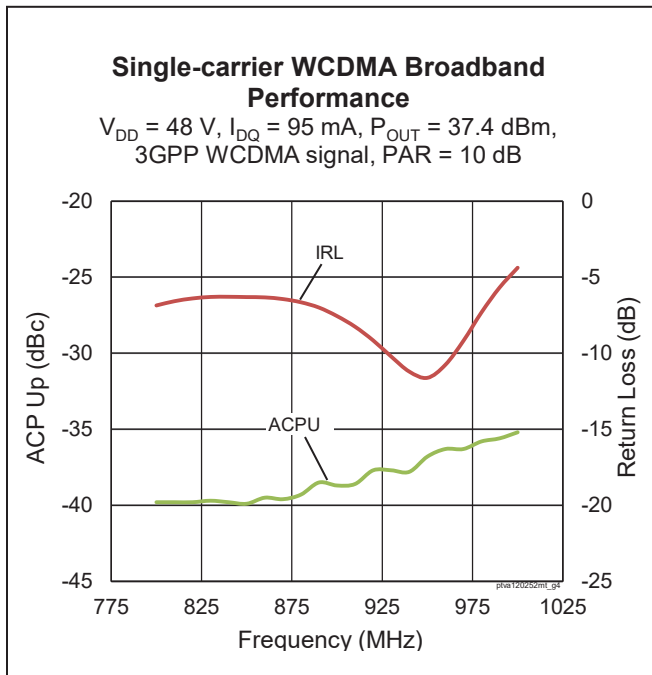
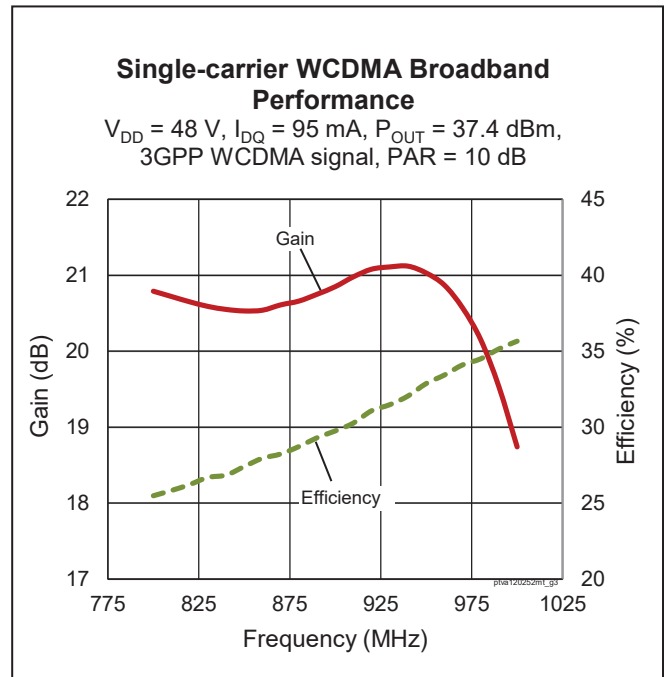
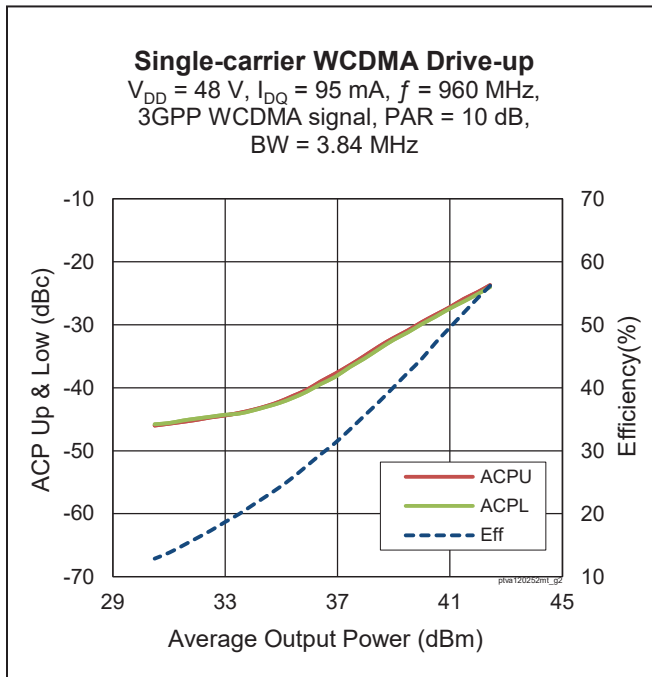

Typical RF Performance (cont.)

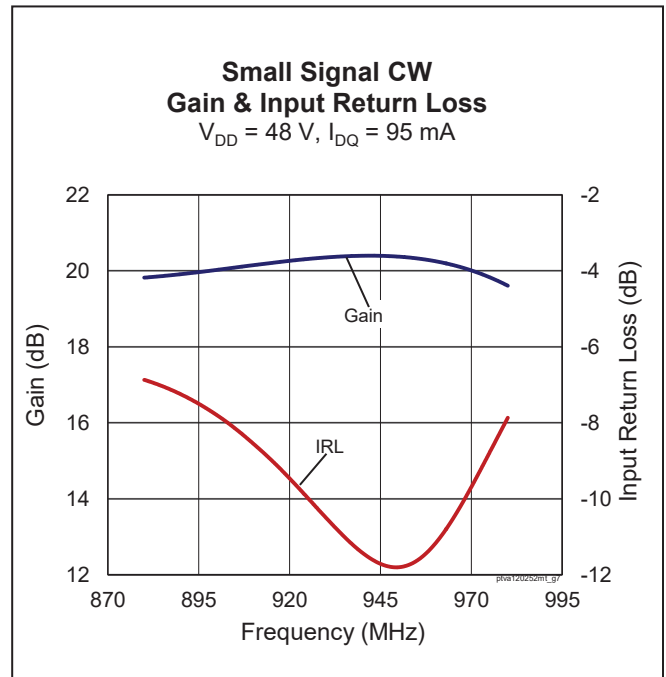
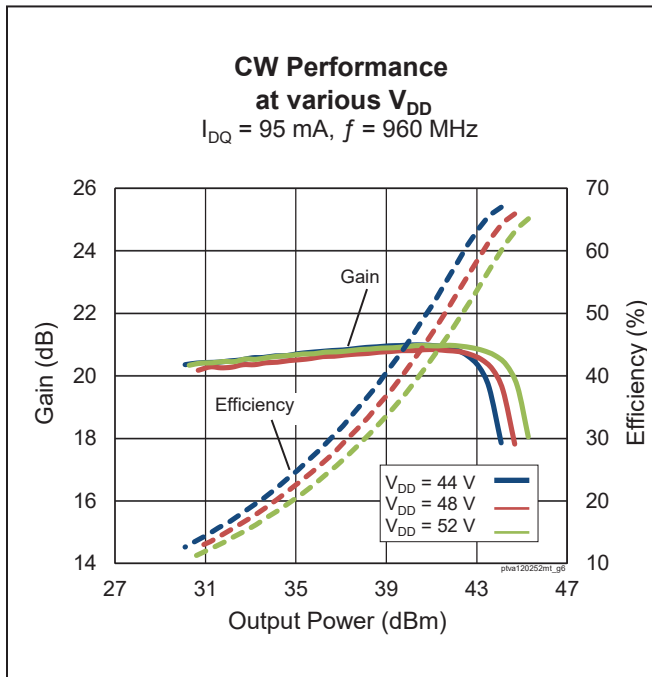

Load Pull Performance

Load Pull Performance – Pulsed CW signal: 10 μs , 10% duty cycle, 48 V, $I_{DQ} = 40 \text{ mA}$

Freq [MHz]	Z_s [Ω]	P_{1dB}									
		Max Output Power					Max PAE				
		Z_I [Ω]	Gain [dB]	P_{OUT} [dBm]	P_{OUT} [W]	PAE [%]	Z_I [Ω]	Gain [dB]	P_{OUT} [dBm]	P_{OUT} [W]	PAE [%]
791	3.12+j7.44	18.94+j8.73	20.85	45.06	32.06	60.1	10.67+j26.27	23.27	41.79	15.10	70.8
821	3.2+j7	18.77+j9.38	20.54	45.03	31.84	59.7	10+j25.7	22.94	41.76	15.00	69.8
869	3.08+j6.56	20.14+j8.78	19.75	44.95	31.26	58.0	14.39+j21	21.46	43.59	22.86	68.0
894	3.02+j6.56	19.72+j9.41	19.41	44.79	30.13	57.5	9.22+j25.02	21.61	41.69	14.76	68.2
925	2.9+j6.12	20.67+j9.26	18.85	45.06	32.06	57.6	14.61+j21.69	20.44	43.55	22.65	66.0
960	2.86+j5.68	18.72+j9.45	18.2	44.80	30.20	55.6	9.75+j23.93	20.24	42.07	16.11	65.5

Reference Circuit, 925 – 960 MHz

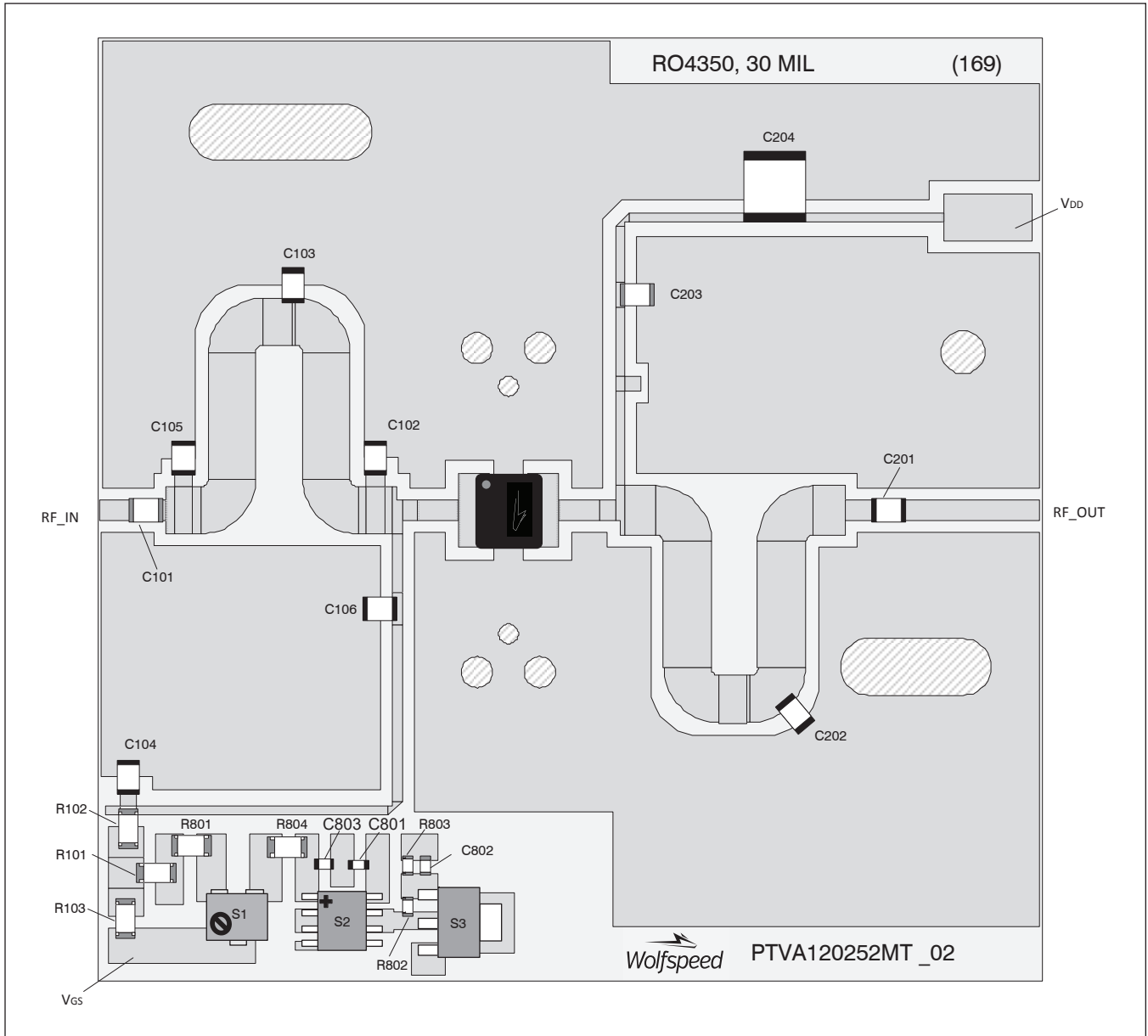

Reference circuit assembly diagram (not to scale)

Reference Circuit (cont.)**Reference Circuit Assembly**

DUT	PTVA120252MT V1
Test Fixture Part No.	LTN/PTVA120252MT V1
PCB	Rogers 4350, 0.762 mm [0.030"] thick, 2 oz. copper, $\epsilon_r = 3.66$, $f = 925 - 960$ MHz
Find Gerber files for this test fixture on the Wolfspeed Web site at http://www.wolfspeed.com/RF	

Components Information

Component	Description	Manufacturer	P/N
Input			
C101, C104, C106	Capacitor, 75 pF	ATC	ATC100B750JW500XB
C102	Capacitor, 14 pF	ATC	ATC100B140KW500XB
C103	Capacitor, 2.2 pF	ATC	ATC100B2R2DW500XB
C105	Capacitor, 2.5 pF	ATC	ATC100B2R5CW500XB
R101, R103	Resistor, 200 ohms	Panasonic Electronic Components	ERJ-8GEYJ201V
R102	Resistor, 10 ohms	Panasonic Electronic Components	ERJ-8GEYJ100V
Output			
C201, C203	Capacitor, 75 pF	ATC	ATC100B750JW500XB
C202	Capacitor, 2.0 pF	ATC	ATC100B2R0CW500XB
C204	Capacitor, 10 μ F	TDK Corporation	C5750X5R1H106K230KA
C801, C802, C803	Capacitor, 1000 pF	Panasonic Electronic Components	ECJ-1VB1H102K
R801	Resistor, 10 ohms	Panasonic Electronic Components	ERJ-8GEYJ100V
R802	Resistor, 1.2K ohms	Panasonic Electronic Components	ERJ-3GEYJ122V
R803	Resistor, 1.3K ohms	Panasonic Electronic Components	ERJ-3GEYJ132V
R804	Resistor, 100 ohms	Panasonic Electronic Components	ERJ-8GEYJ101V
S1	Potentiometer 2K ohms	Bourns Inc.	3224W-1-202E
S2	Voltage Regulator	Texas Instruments	LM78L05ACM
S3	Transistor	Infineon Technologies	BCP56

Pinout Diagram (top view)

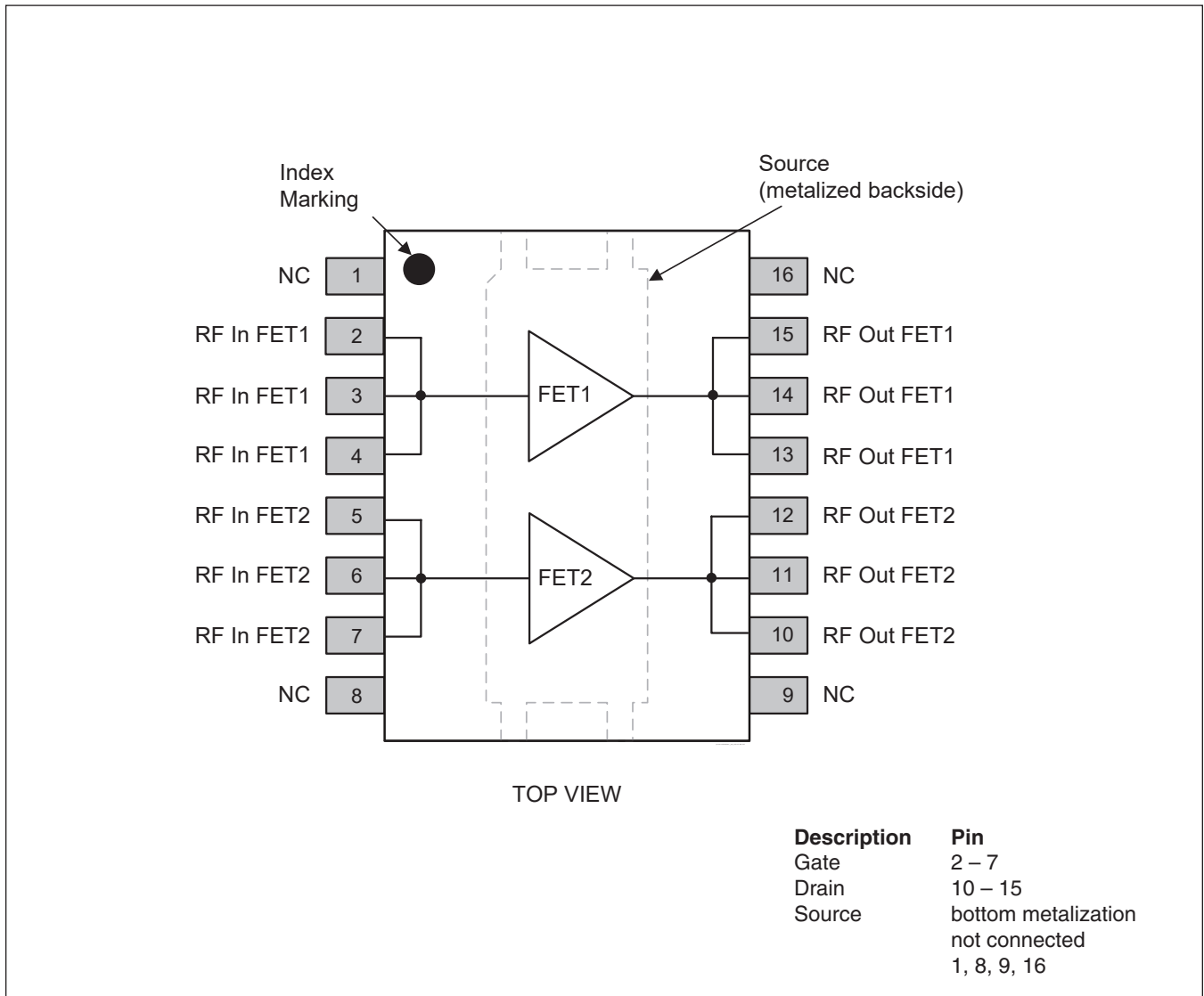

Package Outline Specifications

