

# PXFE181507FC

## Thermally-Enhanced High Power RF LDMOS FET 175 W, 28 V, 1805 – 1880 MHz

### Description

The PXFE181507FC is a 175-watt LDMOS FET intended for use in multi-standard cellular power amplifier applications in the 1805 to 1880 MHz frequency band. Features include input and output matching, high gain and thermally-enhanced package with earless flange. Manufactured with Wolfspeed's advanced LDMOS process, this device provides excellent thermal performance and superior reliability

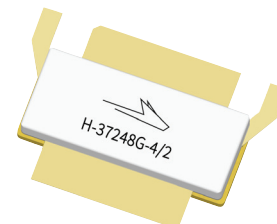

PXFE181507FC  
Package H-37248G-4/2

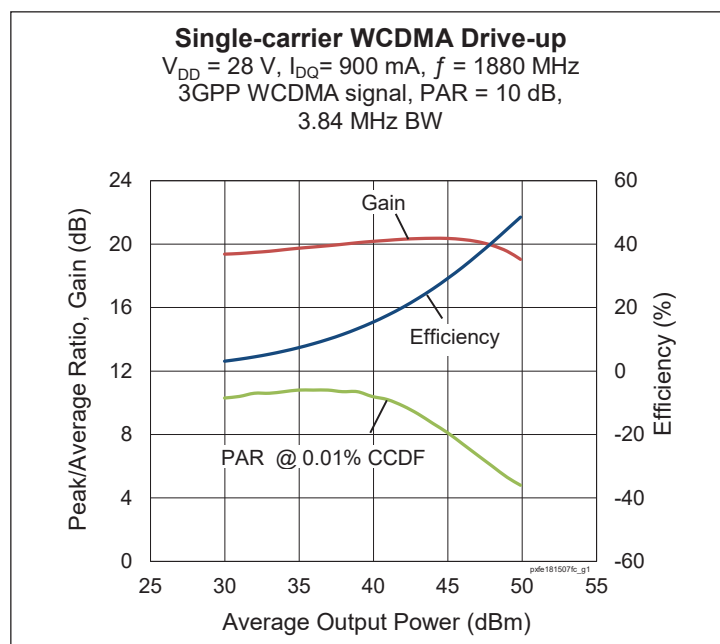

### Features

- Broadband internal input and output matching
- Typical Pulsed CW performance, 1842 MHz, 28 V, single side, 16  $\mu\text{s}$ , 10% duty cycle, class AB test
  - Output power at  $P_{1dB} = 175\text{ W}$
  - Output power at  $P_{3dB} = 222\text{ W}$
  - Efficiency at  $P_{3dB} = 60\%$
  - Gain = 21.3 dB
- Capable of handling 10:1 VSWR @ 28 V, 180 W (CW) output power
- Human Body Model Class 2 (per ANSI/ESDA/JEDEC JS-001)
- Integrated ESD protection
- Low thermal resistance
- Pb-free and RoHS compliant

### RF Characteristics

#### Single-carrier WCDMA Specifications (tested in Wolfspeed production test fixture)

$V_{DD} = 28\text{ V}$ ,  $I_{DQ} = 900\text{ mA}$ ,  $P_{OUT} = 50\text{ W avg}$ ,  $f = 1880\text{ MHz}$ , 3GPP signal, channel bandwidth = 3.84 MHz, peak/average = 10 dB @ 0.01% CCDF

Characteristic	Symbol	Min	Typ	Max	Unit
Gain	$G_{ps}$	19	20	—	dB
Drain Efficiency	$\eta_D$	32	36	—	%
Adjacent Channel Power Ratio	ACPR	—	-31	-27	dBc
Output PAR at 0.01% probability on CCDF	OPAR	5.7	6.2	—	dB

All published data at  $T_{CASE} = 25^\circ\text{C}$  unless otherwise indicated

ESD: Electrostatic discharge sensitive device—observe handling precautions!



### DC Characteristics

Characteristic	Conditions	Symbol	Min	Typ	Max	Unit
Drain-Source Breakdown Voltage	$V_{GS} = 0\text{ V}, I_{DS} = 10\text{ mA}$	$V_{(BR)DSS}$	65	—	—	V
Drain Leakage Current	$V_{DS} = 28\text{ V}, V_{GS} = 0\text{ V}$	$I_{DSS}$	—	—	1	$\mu\text{A}$
	$V_{DS} = 63\text{ V}, V_{GS} = 0\text{ V}$	$I_{DSS}$	—	—	10	$\mu\text{A}$
Gate Leakage Current	$V_{GS} = 10\text{ V}, V_{DS} = 0\text{ V}$	$I_{GSS}$	—	—	1	$\mu\text{A}$
On-State Resistance	$V_{GS} = 10\text{ V}, V_{DS} = 0.1\text{ V}$	$R_{DS(on)}$	—	0.08	—	$\Omega$
Operating Gate Voltage	$V_{DS} = 28\text{ V}, I_{DQ} = 900\text{ mA}$	$V_{GS}$	2.6	3.0	3.4	V

### Maximum Ratings

Parameter	Symbol	Value	Unit
Drain-Source Voltage	$V_{DSS}$	65	V
Gate-Source Voltage	$V_{GS}$	-6 to +10	V
Operating Voltage	$V_{DD}$	0 to +32	V
Junction Temperature	$T_J$	225	$^{\circ}\text{C}$
Storage Temperature Range	$T_{STG}$	-65 to +150	$^{\circ}\text{C}$

### Thermal Characteristics

Characteristic	Symbol	Value	Unit
Thermal Resistance ( $T_{CASE} = 70^{\circ}\text{C}, 50\text{ W CW}$ )	$R_{\theta JC}$	0.55	$^{\circ}\text{C/W}$

### Ordering Information

Type and Version	Order Code	Package	Shipping
PXFE181507FC V1 R0	PXFE181507FC-V1-R0	H-37248G-4/2	Tape & Reel, 50 pcs
PXFE181507FC V1 R2	PXFE181507FC-V1-R2	H-37248G-4/2	Tape & Reel, 250 pcs

Typical Performance (data taken in test fixture)

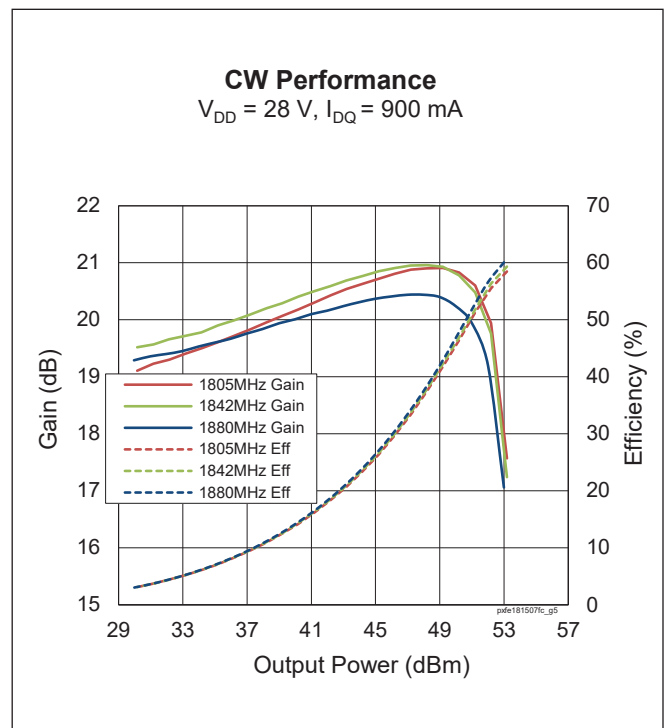
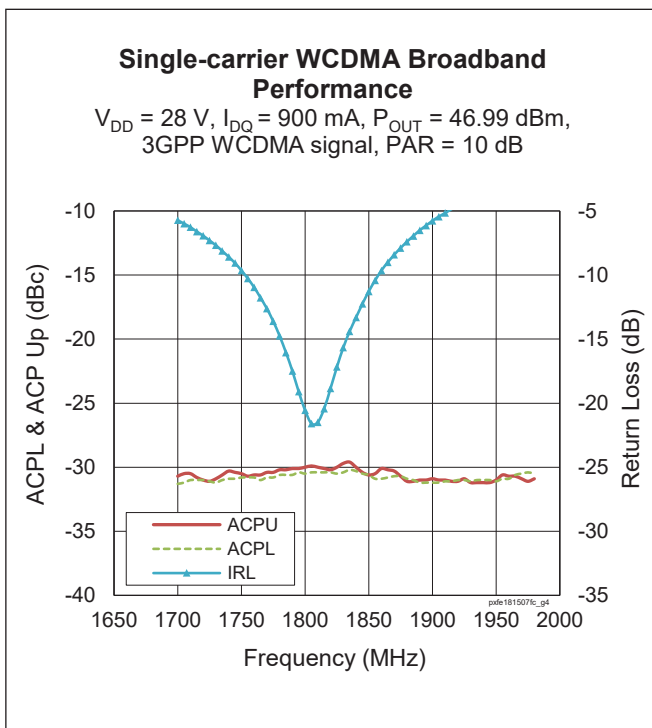
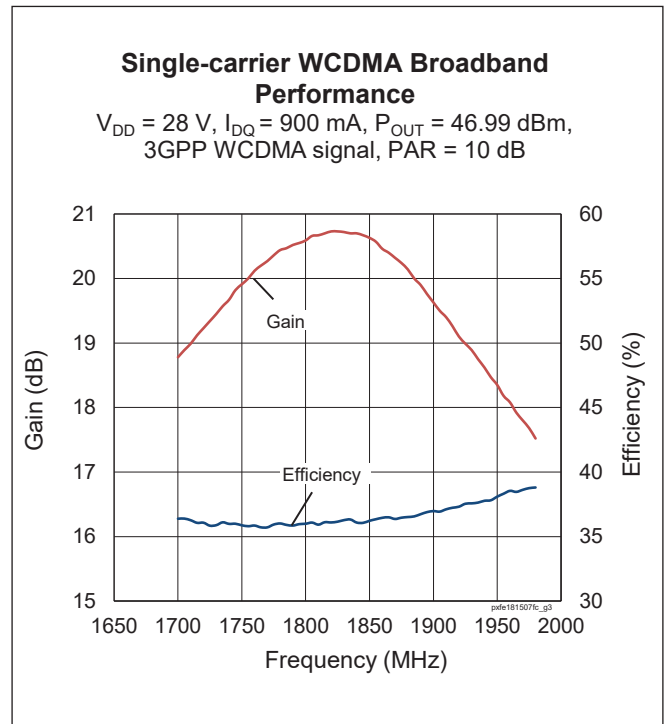
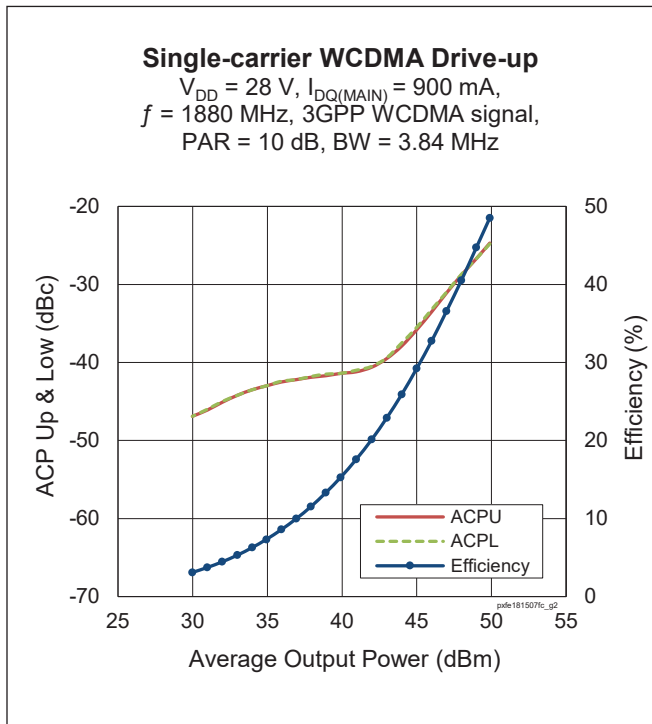

Typical Performance (cont.)

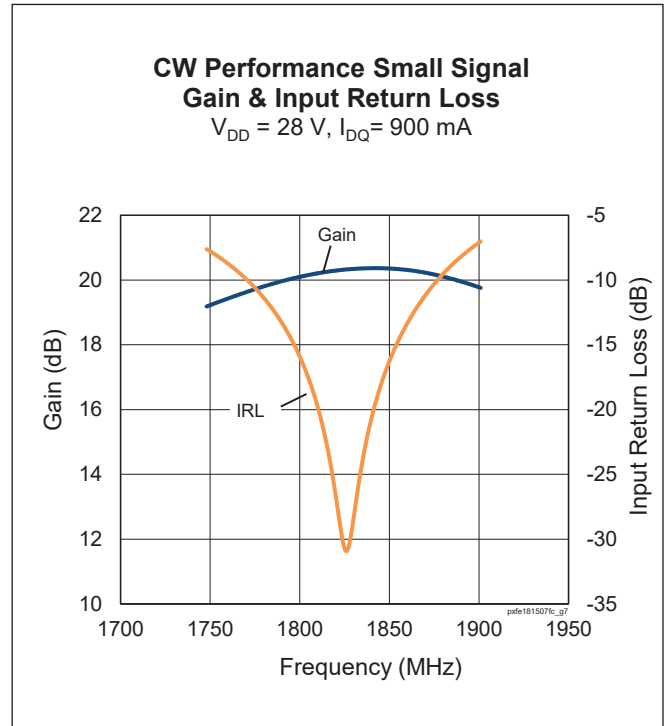
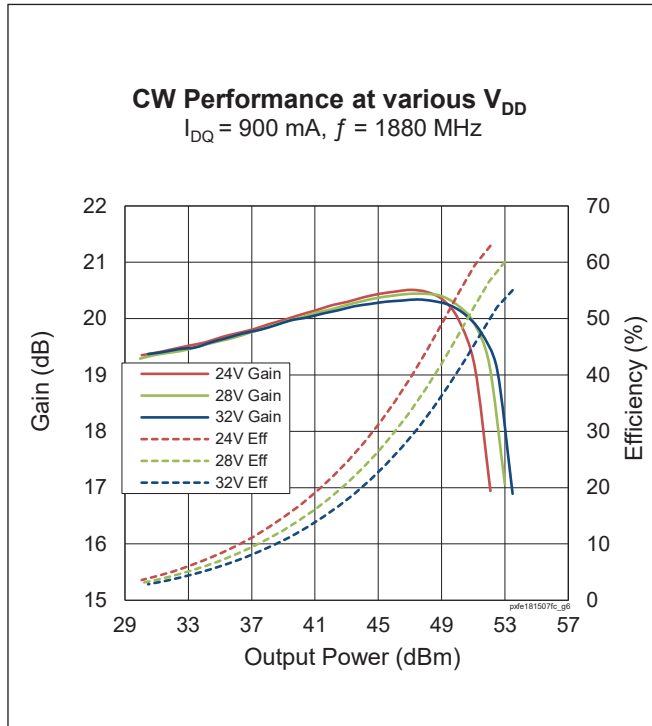

Load Pull Performance

Each Side Load Pull Performance – Pulsed CW signal: 16  $\mu\text{s}$ , 10% duty cycle, 28 V,  $I_{DQ} = 900 \text{ mA}$

		$P_{1dB}$									
		Max Output Power					Max Drain Efficiency				
Freq [MHz]	Zs [W]	ZL [W]	Gain [dB]	$P_{1dB}$ [dBm]	$P_{1dB}$ [W]	$\eta_D$ [%]	ZL [W]	Gain [dB]	$P_{1dB}$ [dBm]	$P_{1dB}$ [W]	$\eta_D$ [%]
1810	7.5-j5.6	1.61-j3.21	19.79	52.87	193.6	59.6	4.1-j0.6	22.6	49.9	98	70.4
1880	12.6-j7	1.38-j2.91	20.15	52.78	189.67	56.94	3.29-j1.56	22.63	50.6	114.8	69

		$P_{3dB}$									
		Max Output Power					Max Drain Efficiency				
Freq [MHz]	Zs [W]	ZL [W]	Gain [dB]	$P_{3dB}$ [dBm]	$P_{3dB}$ [W]	$\eta_D$ [%]	ZL [W]	Gain [dB]	$P_{3dB}$ [dBm]	$P_{3dB}$ [W]	$\eta_D$ [%]
1810	7.5-j5.6	1.61-j3.21	17.79	53.64	231.2	62.47	3.12-j1.98	19.72	52.03	159.6	70.93
1880	12.6-j7	1.58-j3.47	17.83	53.57	227.5	58.69	3.13-j1.84	20.44	51.67	146.9	70.74

Reference Circuit, 1805 – 1880 MHz

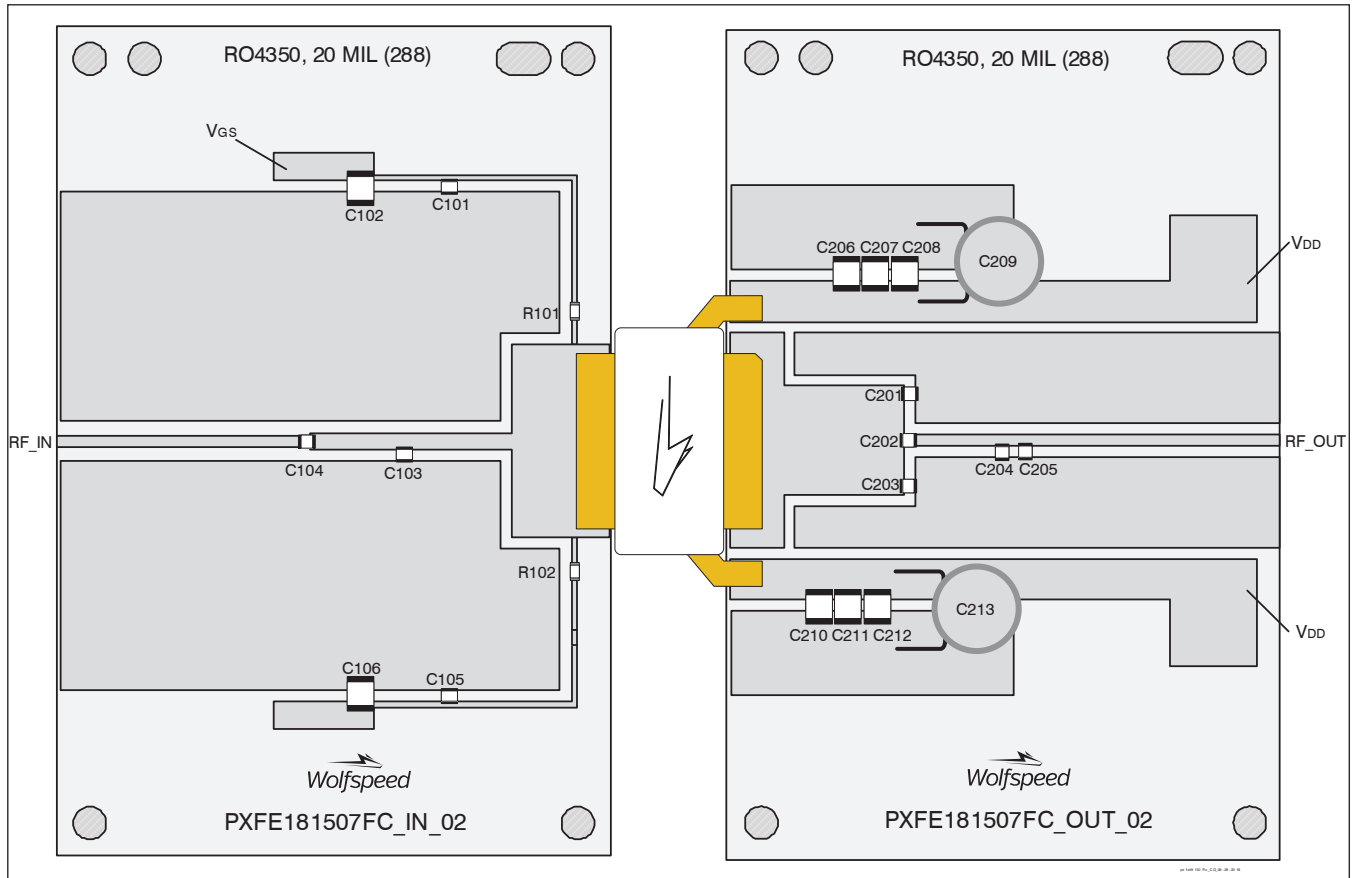

Reference circuit assembly diagram (not to scale)

Reference Circuit Assembly

DUT	PXFE181507FC V1
Test Fixture Part No.	LTN/PXFE181507FC V1
PCB	Rogers 4350, 0.508 mm [0.020"] thick, 2 oz. copper, $\epsilon_r = 3.66$ , $f = 1805 - 1880$ MHz
Find Gerber files for this test fixture on the Wolfspeed Web site at <a href="http://www.wolfspeed.com/RF">www.wolfspeed.com/RF</a>	

Components Information

Component	Description	Manufacturer	P/N
<b>Input</b>			
C101, C104, C105	Capacitor, 12 pF	ATC	ATC600F120JT250XT
C102, C106	Capacitor, 10 $\mu$ F, 50 V	Taiyo Yuden	UMK325C7106MM-T
C103	Capacitor, 1 pF	ATC	ATC600F1R0CT250XT
R101, R102	Resistor, 10 ohms	Panasonic Electronic Components	ERJ-3GEYJ100V
<b>Output</b>			
C201, C203, C204	Capacitor, 0.2 pF	ATC	ATC600F0R2BT250XT
C202	Capacitor, 12 pF	ATC	ATC600F120JT250XT
C205	Capacitor, 0.4 pF	ATC	ATC600F0R4BT250XT
C206, C207, C208, C210, C211, C212	Capacitor, 10 $\mu$ F, 50 V	Taiyo Yuden	UMK325C7106MM-T
C209, C213	Capacitor, 220 $\mu$ F, 100 V	Panasonic Electronic Components	ECA-2AHG221



**Pinout Diagram** (top view)

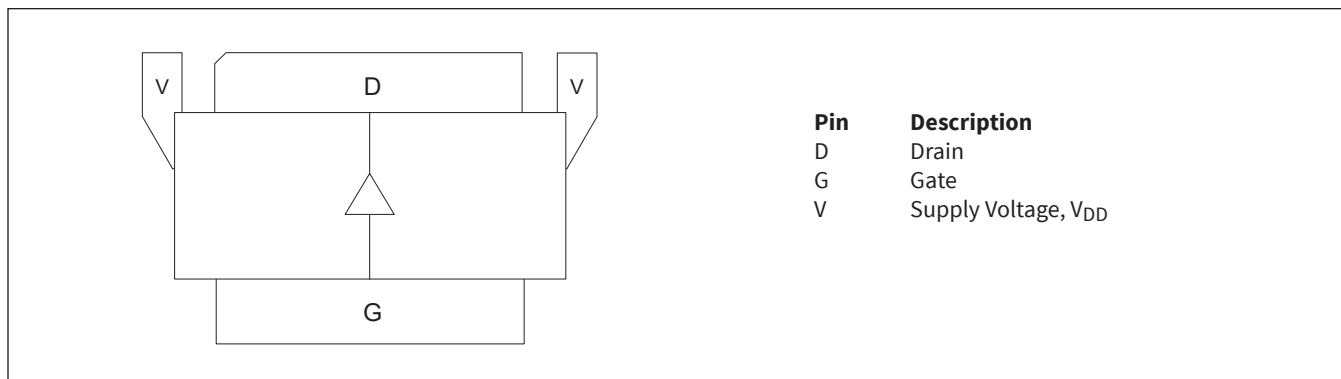

*Lead connections for PXFE181507FC*

**See next page for Package Outline Specifications**

Package Outline Specifications

