

Screwless Clamp Terminal Socket PYF□□S

- Screwless clamping greatly contributes to reducing wiring time.
- No over or under tightening of cable connection so better contact reliability is achieved.
- Double wiring possible on all the terminals, and easy bridge and branch connections.
- Use either solid or stranded wires from 0.2 to 1.5 mm² (AWG24 to AWG16).
- Safe terminal arrangement: Coil terminals separated from contact terminals.
- Unique ejector enables easy relay replacement.
- Nameplate available
- Finger-protection

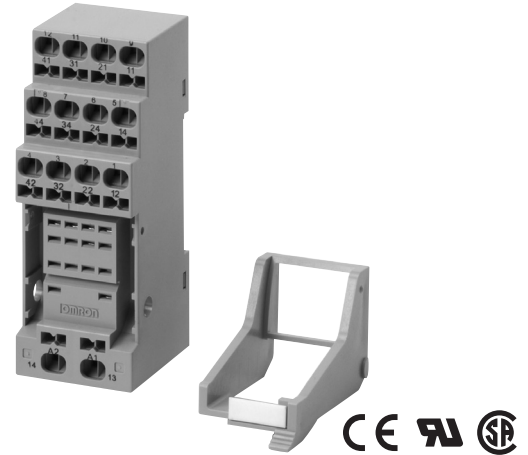

Ordering Information

■ List of Models

	4-pole for MY4/MY2	2-pole for MY2
Socket	PYF14S	PYF08S
Clip & Release Lever	PYCM-14S	PYCM-08S
Nameplate	R99-11	
Socket Bridge	PYDM-14SR, PYDM-14SB	PYDM-08SR, PYDM-08SB

Specifications

■ Ratings/Characteristics

Item	PYF14S	PYF08S	Remarks
Relay	MY2 Series MY4 Series	MY2 Series	---
Dimensions	31 × 85 × 36.5 mm max. (W × H × D)	23.2 × 85 × 36.5 mm max. (W × H × D)	---
Rated voltage	250 VAC		---
Rated carry current	10 A at 55°C with MY2 (S) 7 A at 70°C with MY2 (S) 5 A at 70°C with MY4 (S)	10 A at 55°C with MY2 (S) 7 A at 70°C with MY2 (S)	VDE0627
Applicable wires	0.2 to 1.5 mm ² (AWG24 to AWG16) Solid wire Stranded wire		---
Number of wire connections	2 wires per terminal (1 wire per hole)		---
Clamping force	10 N min. (0.2 mm ²) 40 N min. (1.5 mm ²)		EN60999

■ Approved Standards

Standard	File No.
VDE0627 (IEC664, EN60999)	112467UG
UL508 (UL1059)	E87929 Vol. 3
CSA C22.2 No. 14 (CSA C22.2 No. 158)	LR31928

Dimensions

Note: All units are in millimeters unless otherwise indicated.

PYF14S

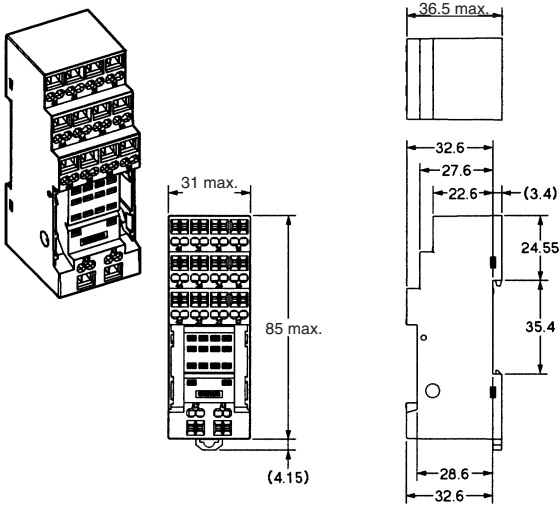

PYF08S

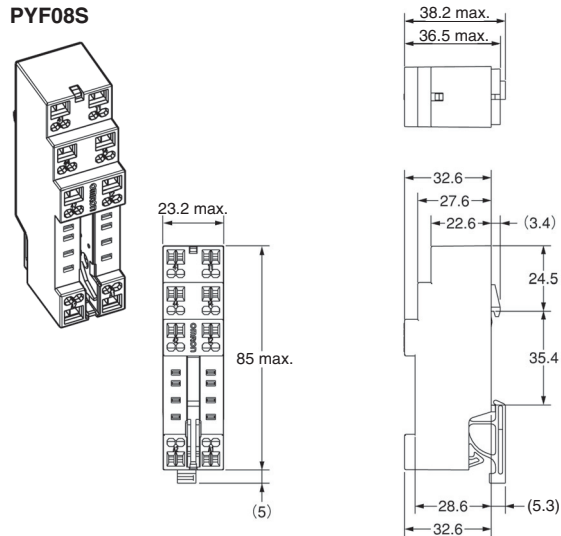

Terminal Arrangement

PYF14S

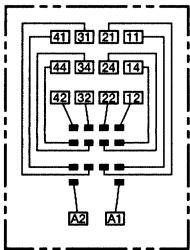

PYF08S

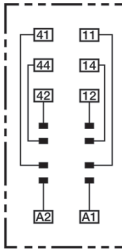

Common contacts
Make contacts
Break contacts
Coil

Note: In case MY2 relay will be used in combination with PYF14S terminals 21, 22, 24 and 31, 32, 34 are not connected.

Mounting Height (With Lever)

PYF14S

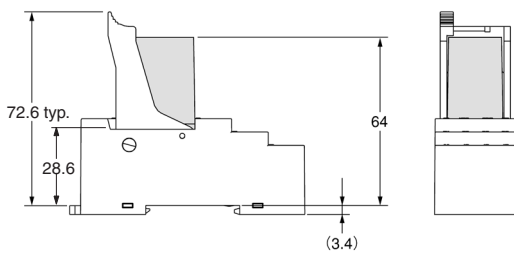

PYF08S

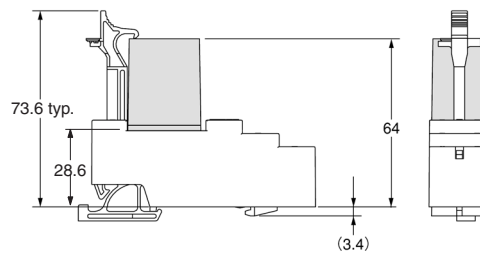

■ Accessories (Option)

Socket Bridge for PYF-S

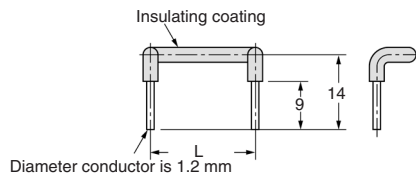

List of models

Socket	Model number	Length L (mm)	Color of insulating coating
PYF14S	PYDM-14SR	27.5	Red
	PYDM-14SB		Blue
PYF08S	PYDM-08SR	19.7	Red
	PYDM-08SB		Blue

Specification

Item	Characteristic
Rated ON current	10 A
Rated insulation voltage	250 VAC
Temperature rise	35°C max.
Dielectric strength	1,500 VAC for 1 minute
Ambient operating temperature	-55 to 70°C

Levers for PYF-S

PYCM-14S for PYF14S

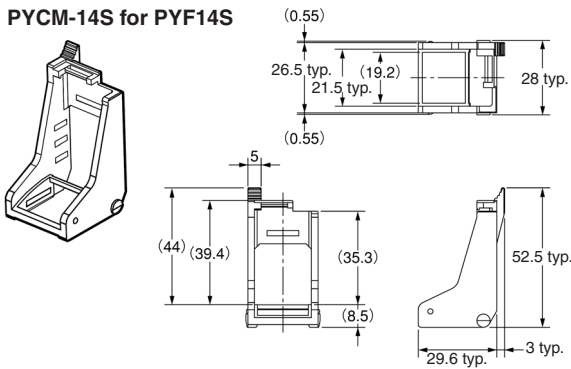

PYCM-08S for PYF08S

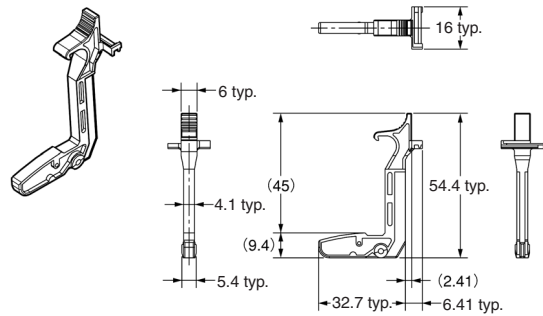

Installation

■ Tools

A flat-blade screwdriver should be used to mount the cables.

Applicable Screwdriver

- Flat-blade, Parallel-tip, 2.5 mm diameter (3.0 mm max.)

- Flat-blade, Parallel-tip



- Flat-blade, Flared-tip



Cannot be used.

Examples: FACOM AEF.2.5 × 75E (AEF. 3 × 75E)
 VESSEL No. 9900-(-)2.5 × 75 (No. 9900-(-)3 × 100)
 WAGO 210-119
 WIHA 260/2.5 × 40 (260/3 × 50)

*Chamfering the tip of the driver improves insertion when used as an exclusive tool.

■ Applicable Wires

Applicable Wire Sizes

0.2 to 1.5 mm², AWG24 to AWG16

Applicable Wire Type

Solid wires, stranded wires, flexible wires, or wires with ferules can be used.

(See note 1.) $2.2 \leq \text{Diameter } D \text{ (mm)} \leq 3.2$ (3.5: see note 2.)

Conductor diameter d (mm) or length of sides a and b (mm) ≤ 1.9

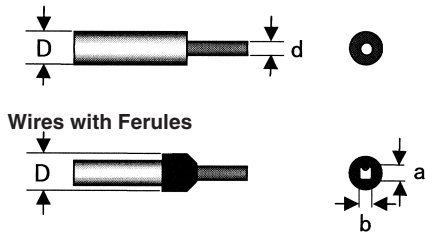

Note: 1. If the outer diameter D of the wire is less than 2.2 mm and the exposed conductor length is less than 8 mm potentially bad connection might occur in case wire is pushed to far inside. Please see following drawing.

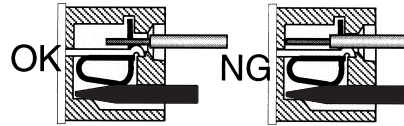

2. If the outer diameter D of the wire exceeds 3.2 mm, it might be difficult to use double wiring.

Examples of Applicable Wires (Confirmed Using Catalog Information)

Type of wire	Conductor type	See note 1, above.	Recommended wire sizes	See note 2, above.
Equipment wire 2491X	Flexible		0.5, 0.75, 1.0 mm ²	1.5 mm ²
BS6004	Solid	0.5 mm ²		
Switchgear BS6231	Solid		1.0 mm ²	1.5 mm ²
Switchgear BS6231	Flexible		0.5, 0.75 mm ²	1.0 mm ²
Tri-rated control and switchgear	Flexible		0.5, 0.75, 1.0, 1.5 mm ²	
Conduit	Stranded		1.5 mm ²	
UL1007	Flexible	18AWG	16AWG	
UL1015	Flexible		18AWG, 16AWG	
UL1061	Flexible	18AWG		
UL1430	Flexible	18AWG	16AWG	

■ Wiring

Use wires of the applicable sizes specified above. The length of the exposed conductor should be 8 to 9 mm.

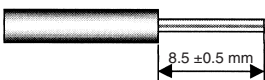

Fig. 1 Exposed Conductor Length

Use the following wiring procedure.

1. Insert the specified screwdriver into the release hole located beside the wire connection hole where the wire is to be inserted.

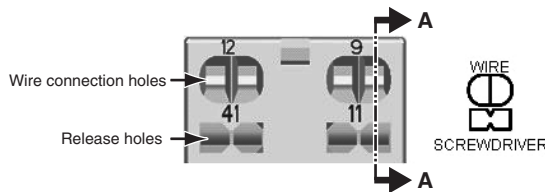

Fig. 2 Wire Connection Holes and Release Holes

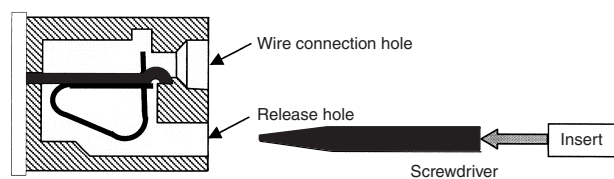
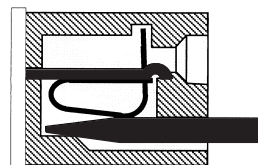
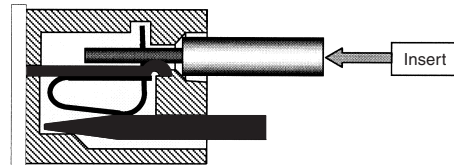

Fig. 3 Section A-A of Fig. 2



2. Insert the exposed conductor into the wire connection hole.



3. Pull out the screwdriver.

