

# QBL4208-1024-AT Hardware Manual

Hardware Version V1.00 | Document Revision V1.00 • 22.02.2019

**QBL4208-1024-AT is a NEMA17 (42mm) 3-phase BLDC motor including a small size optical incremental encoder kit. It comes with a resolution up to 1024 lines (4096 counts). Trinamic's BLDC motors are quality motors for universal use. They feature a long life due to ball bearings and no wearing out parts.**



## Features

- Low Cost
- High Resolution
- Small Dimension
- Standard Incremental Encoder Interface

## Applications

- Closed Loop Servo Motors
- Industrial Automation
- Automated Equipment
- Robotics

## Simplified Block Diagram

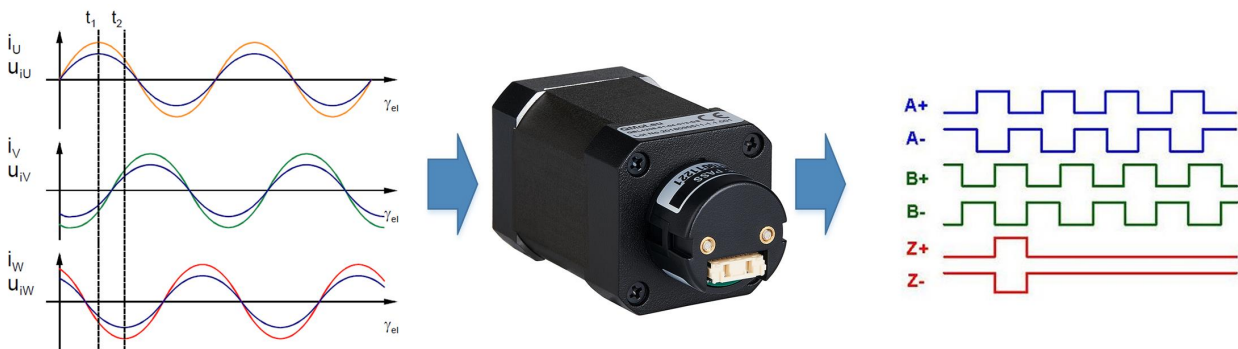

## Contents

<b>1</b>	<b>Order Codes</b>	<b>3</b>
<b>2</b>	<b>Motor Specifications and Characteristics</b>	<b>4</b>
2.1	Technical and Mechanical Parameters	4
2.2	Torque-Speed Diagrams	5
2.2.1	QBL4208-61-04-013	5
2.2.2	QBL4208-100-04-025	6
<b>3</b>	<b>Technical Specifications of the Encoders</b>	<b>6</b>
3.1	Electrical Encoder Parameters	6
3.2	Mechanical Encoder Parameters	7
3.3	Environmental Encoder Parameters	7
<b>4</b>	<b>Connectors and Signals</b>	<b>7</b>
4.1	Motor Connector	7
4.2	Encoder Connector	8
4.3	Wave Form	9
<b>5</b>	<b>Mechanical Drawings</b>	<b>9</b>
<b>6</b>	<b>Motor Sizing</b>	<b>10</b>
6.1	Peak Torque Requirement	10
6.2	RMS Torque Requirement	10
6.3	Motor Velocity	10
<b>7</b>	<b>Figures Index</b>	<b>12</b>
<b>8</b>	<b>Tables Index</b>	<b>13</b>
<b>9</b>	<b>Supplemental Directives</b>	<b>14</b>
9.1	Producer Information	14
9.2	Copyright	14
9.3	Trademark Designations and Symbols	14
9.4	Target User	14
9.5	Disclaimer: Life Support Systems	14
9.6	Disclaimer: Intended Use	14
9.7	Collateral Documents & Tools	15
<b>10</b>	<b>Revision History</b>	<b>16</b>
10.1	Hardware Revision	16
10.2	Document Revision	16



## 1 Order Codes

Order Code	Description	Size (LxWxH)
QBL4208-61-04-013-1024-AT	Motor + Encoder Module, NEMA17 3-phase BLDC motor (3.5A / 0.13Nm, 4000rpm, round shaft) with 28mm diameter optical incremental encoder kit, resolution of 1.024lpr (4.096cpr), ABN, TTL	42mm x 42mm x 79mm
QBL4208-100-04-025-1024-AT	Motor + Encoder Module, NEMA17 3-phase BLDC motor (7.0A / 0.25Nm, 4000rpm, round shaft) with 28mm diameter optical incremental encoder kit, resolution of 1.024lpr (4.096cpr), ABN, TTL	42mm x 42mm x 118mm

*Table 1: Order codes*

Other encoder resolutions, signal output types, and customized motor options on request.



## 2 Motor Specifications and Characteristics

TRINAMIC's BLDC motors are quality motors for universal use. They feature a long life due to ball bearings and no wearing out parts. These BLDC motors give a good fit to the TRINAMIC family of medium and high current BLDC motor modules and custom/customized solutions.

### 2.1 Technical and Mechanical Parameters

The main characteristics are:

- Shaft run out: 0.025mm
- Insulation Class: B
- Radial Play: 0.02mm 450G load
- Max Radial Force: 28N (10mm from flange)
- Max Axial Force: 10N
- Dielectric Strength: 500 VDC For One Minute
- Insulation Resistance: 100M Ohm min. 500VDC
- Recommended Ambient Temp.: -20 to +40°C
- Bearing: Brushless motors fitted with ball bearings
- Coil windings in delta topology

Specifications	Unit	QBL4208-61-04-013-1024-AT	QBL4208-100-04-025-1024-AT
No. of Poles		8	8
No. of Phases		3	3
Rated Voltage	V	24	24
Rated Phase Current	A	3.47	6.95
Rated Speed	RPM	4000	4000
Rated Torque	Nm	0.125	0.25
Max Peak Torque	Nm	0.38	0.75
Torque Constant	Nm/A	0.036	0.036
Line to Line Resistance	$\Omega$	0.72	0.28
Line to Line Inductance	mH	1.2	0.54
Max Peak Current	A	10.6	20
Length (LMAX)	mm	61	100
Rotor Inertia	$\text{kgm}^2 \times 10^{-6}$	48	96
Mass	kg	0.45	0.8

Table 2: Electrical and Mechanical Characteristics Motor



## 2.2 Torque-Speed Diagrams

The torque-speed figures detail motor torque characteristics measured in block commutation. Please be careful not to operate the motors outside the blue field. This is possible for short times only because of a resulting high coil temperature. The motors have insulation class B. The blue field is described by rated speed and rated torque.

### 2.2.1 QBL4208-61-04-013

Velocity vs. torque measured with 24V supply voltage.

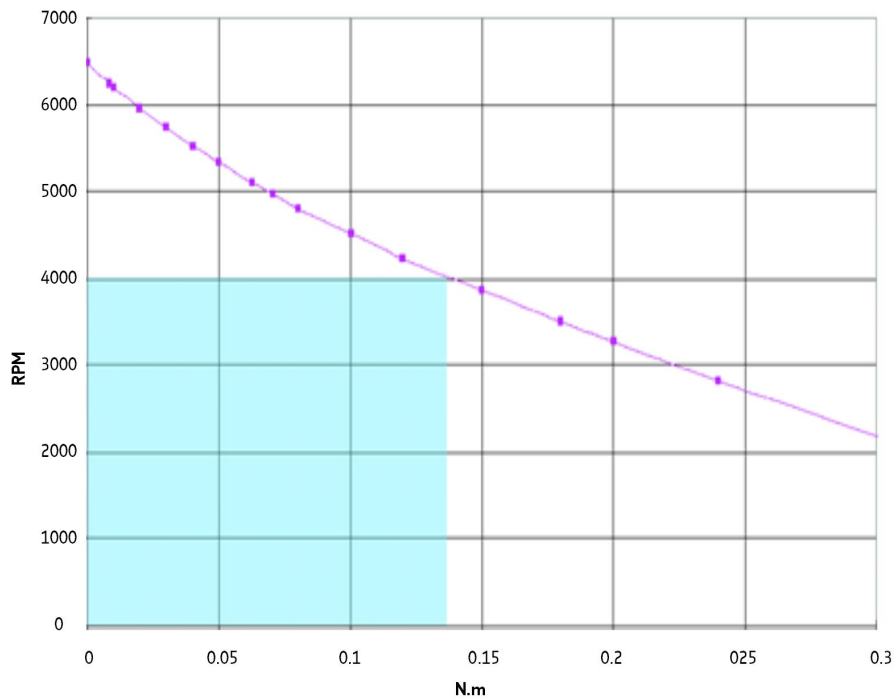

Figure 1: QBL4208-61-04-013 velocity vs. torque characteristic



### 2.2.2 QBL4208-100-04-025

Velocity vs. torque measured with 24V supply voltage.

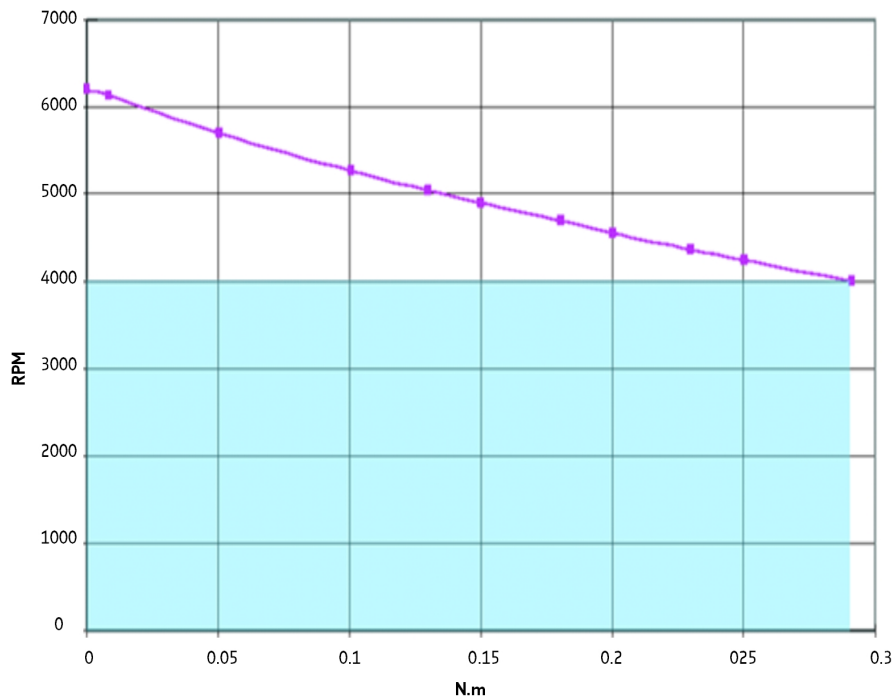

Figure 2: QBL4208-100-04-025 velocity vs. torque characteristics

## 3 Technical Specifications of the Encoders

### 3.1 Electrical Encoder Parameters

Parameter	Min	Typ	Max	Unit
Supply voltage	4.5	5	5.5	V
Supply current			110	mA
Rise/fall time			10	ns
Frequency			1500	kHz
Output Voltage "H"	2.4			V
Input Voltage "L"			0.4	V
Max. output current			20	mA
Resolution		4096		increments

Table 3: Electrical Characteristics Encoder



## 3.2 Mechanical Encoder Parameters

Parameter	Min	Typ	Max	Unit
Hollow Diameter (symbol D in drawings)		5 / 6.35		mm
Starting Torque			0.8	Ncm
Shaft Loading Axial			50	N
Shaft Loading Radial			80	N
Max. RPM			6000	rpm
Net weight		30		g

Table 4: Mechanical Specifications

## 3.3 Environmental Encoder Parameters

Parameter	Description
Operating Temperature	-20 – +85°C
Storage Temperature	-20 – +85°C
Operating Humidity	RH 85% max, non collecting
Shock	490 $m/s^2$ , 3Dx2 times
Vibration	1.2mm, 10-55kHz, 3Dx30min
Protection	IP40

Table 5: Environmental Specifications

# 4 Connectors and Signals

## 4.1 Motor Connector

Color	Wire Type	Signal Name
Yellow	UL1007 AWG20	Phase U
Red	UL1007 AWG20	Phase V
Black	UL1007 AWG20	Phase W

Table 7: Connector and signals of motor



## 4.2 Encoder Connector

Pin Number	Color	Wire Type	Signal Name
1	Red	UL2517 AWG28	VCC
2	Black	UL2517 AWG28	GND
3	White	UL2517 AWG28	A+
4	White/Black	UL2517 AWG28Black	A-
5	Green	UL2517 AWG28	B+
6	Green/Black	UL2517 AWG28	B-
7	Yellow	UL2517 AWG28	Z+
8	Yellow/Black	UL2517 AWG28	Z-
9	Blue	UL2517 AWG28	Shield

Table 9: Connector and signals of the encoder

The required encoder cable connector is a Molex type 5023800900 CLIK-MATE™ crimp housing using Molex type 5023810000 CLIK-MATE™ crimp terminals.

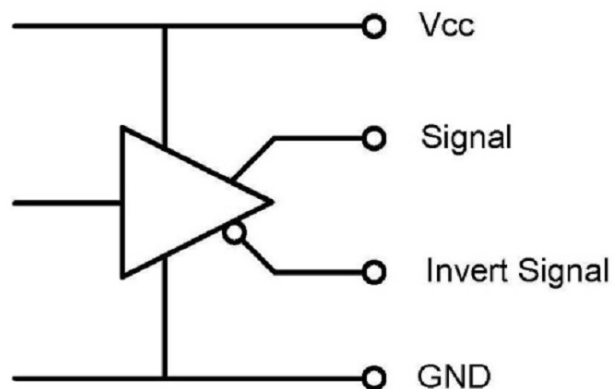

Figure 3: Connection and circuit diagram for the line driver outputs





### 4.3 Wave Form

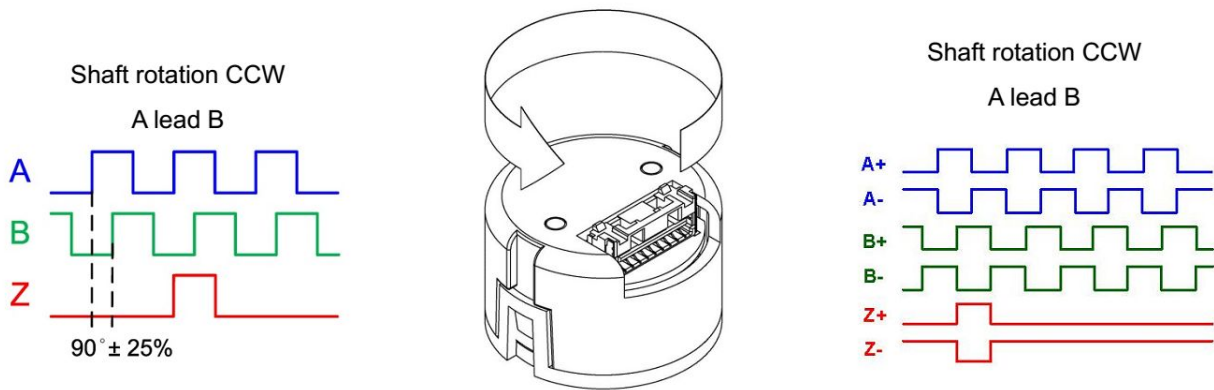

Figure 4: Example wave form for CCW rotation

### 5 Mechanical Drawings

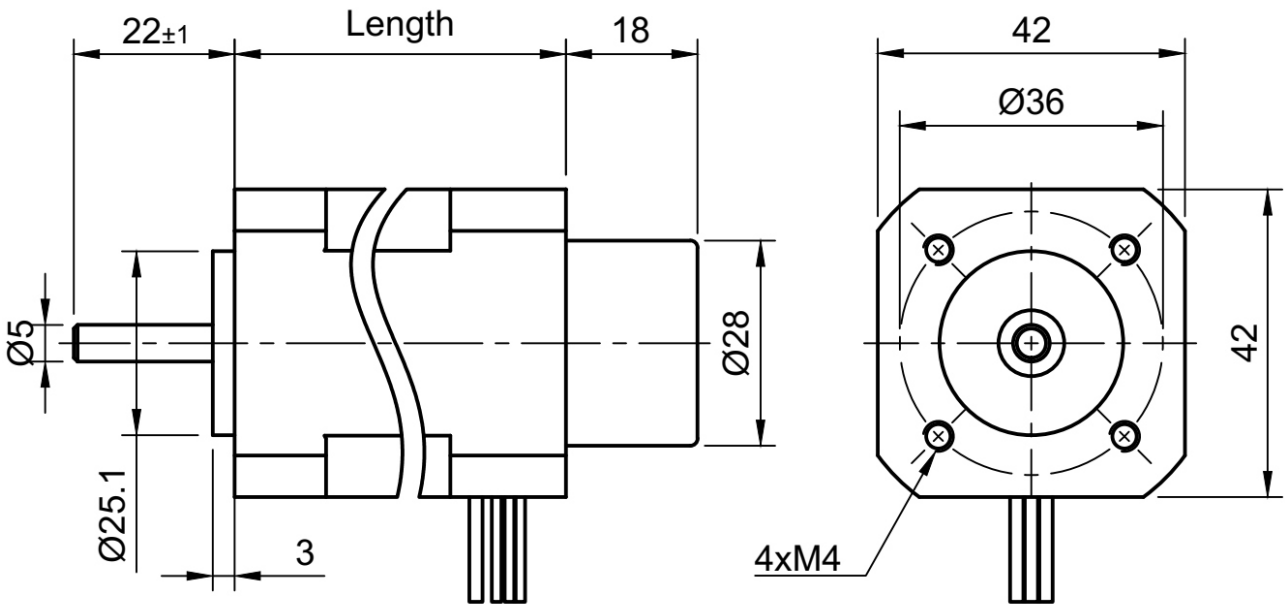

Figure 5: Dimensions of motor & encoder kit (all units = mm)

Motor Type	Body Length
QBL4208-61-04-013-1024-AT	61mm
QBL4208-100-04-013-1024-AT	100mm

Table 11: Motor length



## 6 Motor Sizing

For the optimum solution it is important to fit the motor to the application. The three key parameters are peak torque requirement, RMS torque requirement and motor velocity.

### 6.1 Peak Torque Requirement

Peak torque  $T_P$  is the sum of the torque due to acceleration of inertia ( $T_I$ ), load ( $T_L$ ) and friction ( $T_F$ ):

$$T_P = T_J + T_L + T_F$$

The torque due to inertia is the product of the load (including motor rotor) inertia and the load acceleration:

$$T_J = T + a$$

The torque due to the load is defined by the configuration of the mechanical system coupled to the motor. The system also determines the amount of torque required to overcome the friction.

### 6.2 RMS Torque Requirement

Root-Mean-Square or RMS torque is a value used to approximate the average continuous torque requirement. Its statistical approximation is with

- $t_1$ : acceleration time
- $t_2$ : run time
- $t_3$ : deceleration time
- $t_4$ : time in a move

$$T_{RMS} = \sqrt{\frac{T_P^2 + (T_L + T_F)^2 * t_2 + (T_J - T_L - T_F)^2 * t_3}{t_1 + t_2 + t_3 + t_4}}$$

### 6.3 Motor Velocity

The motor velocity is also dictated by the configuration of the mechanical system that is coupled to the motor shaft, and by the type of move that is to be affected. For example, a single velocity application would require a motor with rated velocity equal to the average move velocity. A point to point positioning would require a motor with a rated velocity higher than the average move velocity. (The higher velocity would account for acceleration, deceleration and run times of the motion profile). Figure 6.1: Trapezoidal move and triangular move relates rated motor velocity to average move velocity for two point to point positioning move profiles.



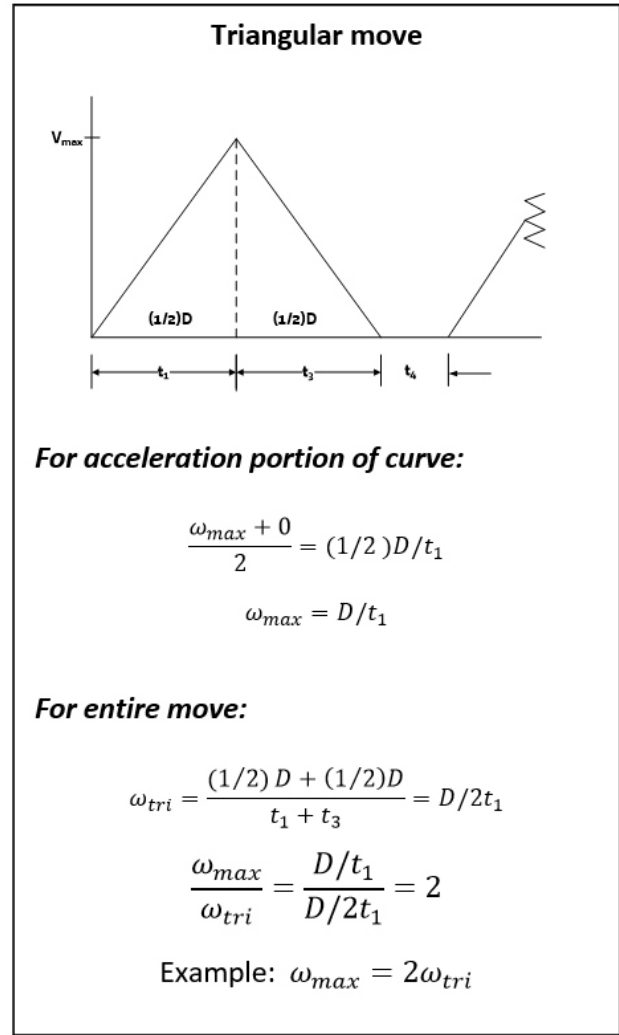
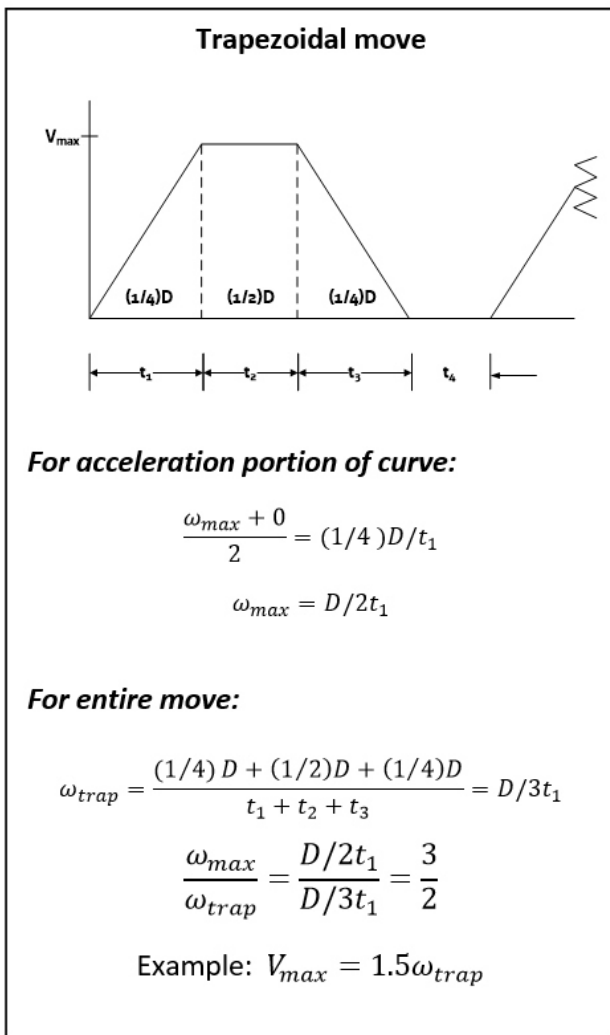

Symbol	Description
$\omega_{max}$	rated operating speed of motor RPM
$\omega_{trap}$	average speed of motor required for a specified trapezoidal move, RPM
$\omega_{tri}$	average speed of motor required for a specified triangular move, RPM
$D$	total distance traveled, motor shaft revolutions
$t_1$	acceleration time, seconds
$t_2$	run time, seconds
$t_3$	deceleration time, seconds
$t_4$	dwell time, seconds

Table 12: Trapezoidal and triangular move symbols



## 7 Figures Index

1 QBL4208-61-04-013 velocity vs. torque characteristic . . . . .	5	3 Connection and circuit diagram for the line driver outputs . . . . .	8
2 QBL4208-100-04-025 velocity vs. torque characteristics . . . . .	6	4 Example wave form for CCW rotation . . . . .	9
		5 Dimensions of motor & encoder kit (all units = mm) . . . . .	9



## 8 Tables Index

1	Order codes . . . . .	3	7	Connector and signals of motor . . . . .	7
2	Electrical and Mechanical Characteristics Motor . . . . .	4	9	Connector and signals of the encoder . . . . .	8
3	Electrical Characteristics Encoder . . . . .	6	11	Motor length . . . . .	9
4	Mechanical Specifications . . . . .	7	12	Trapezoidal and triangular move symbols	11
5	Environmental Specifications . . . . .	7	13	Hardware Revision . . . . .	16
			14	Document Revision . . . . .	16



## 9 Supplemental Directives

### 9.1 Producer Information

### 9.2 Copyright

TRINAMIC owns the content of this user manual in its entirety, including but not limited to pictures, logos, trademarks, and resources. © Copyright 2019 TRINAMIC. All rights reserved. Electronically published by TRINAMIC, Germany.

Redistributions of source or derived format (for example, Portable Document Format or Hypertext Markup Language) must retain the above copyright notice, and the complete Datasheet User Manual documentation of this product including associated Application Notes; and a reference to other available product-related documentation.

### 9.3 Trademark Designations and Symbols

Trademark designations and symbols used in this documentation indicate that a product or feature is owned and registered as trademark and/or patent either by TRINAMIC or by other manufacturers, whose products are used or referred to in combination with TRINAMIC's products and TRINAMIC's product documentation.

This Hardware Manual is a non-commercial publication that seeks to provide concise scientific and technical user information to the target user. Thus, trademark designations and symbols are only entered in the Short Spec of this document that introduces the product at a quick glance. The trademark designation /symbol is also entered when the product or feature name occurs for the first time in the document. All trademarks and brand names used are property of their respective owners.

### 9.4 Target User

The documentation provided here, is for programmers and engineers only, who are equipped with the necessary skills and have been trained to work with this type of product.

The Target User knows how to responsibly make use of this product without causing harm to himself or others, and without causing damage to systems or devices, in which the user incorporates the product.

### 9.5 Disclaimer: Life Support Systems

TRINAMIC Motion Control GmbH & Co. KG does not authorize or warrant any of its products for use in life support systems, without the specific written consent of TRINAMIC Motion Control GmbH & Co. KG.

Life support systems are equipment intended to support or sustain life, and whose failure to perform, when properly used in accordance with instructions provided, can be reasonably expected to result in personal injury or death.

Information given in this document is believed to be accurate and reliable. However, no responsibility is assumed for the consequences of its use nor for any infringement of patents or other rights of third parties which may result from its use. Specifications are subject to change without notice.

### 9.6 Disclaimer: Intended Use

The data specified in this user manual is intended solely for the purpose of product description. No representations or warranties, either express or implied, of merchantability, fitness for a particular purpose



or of any other nature are made hereunder with respect to information/specification or the products to which information refers and no guarantee with respect to compliance to the intended use is given.

In particular, this also applies to the stated possible applications or areas of applications of the product. TRINAMIC products are not designed for and must not be used in connection with any applications where the failure of such products would reasonably be expected to result in significant personal injury or death (safety-Critical Applications) without TRINAMIC's specific written consent.

TRINAMIC products are not designed nor intended for use in military or aerospace applications or environments or in automotive applications unless specifically designated for such use by TRINAMIC. TRINAMIC conveys no patent, copyright, mask work right or other trade mark right to this product. TRINAMIC assumes no liability for any patent and/or other trade mark rights of a third party resulting from processing or handling of the product and/or any other use of the product.

## 9.7 Collateral Documents & Tools

This product documentation is related and/or associated with additional tool kits, firmware and other items, as provided on the product page at: [www.trinamic.com](http://www.trinamic.com).

