

Broadband 50 Watt GaN Power Amplifier

20 to 800 MHz high power, class AB design utilizing GaN technology



*Similar Model

Features

- 65 Watts Typical Saturated Output Power
- Rugged GaN Technology
- Adaptive Biasing to Promote Efficiency
- Optional Forward/Reverse Power Detection
- Blanking Feature Available
- Microprocessor Based Control
 - Fault Monitoring
 - Temperature Compensation
 - Sequencing
 - Interface Options

API Technologies’ Model QBS-559 is a high power, class AB solid state amplifier which utilizes the latest GaN technology to offer broadband performance from 20 to 800 MHz. The RFPA has an integrated, high efficiency DC to DC converter to promote operation over a wide DC input voltage range of +25 to +32 VDC; drawing 5.1 amps with a saturated gain of 41 dB, and a typical output power of 65 watts.

The microprocessor based design incorporates an adaptive biasing algorithm to optimize efficiency and output power across the frequency band under varying load conditions. This rugged, high reliability GaN based amplifier is capable of performing in adverse commercial and military environments with EMI and moisture sealing, and will not be damaged operating into a 10:1 load mismatch at full rated power. Optional RF blanking controlled through an LVDS signal, and forward/reverse power detection are available upon request.

Technical Specifications (25°C) ⁽¹⁾

Parameter	Typical	Min / Max
Frequency Range	20 - 800 MHz	20 - 700 MHz
Linear Gain	47 dB	–
P _{SAT} Gain ⁽²⁾	41 dB	–
Output Power @ P _{SAT}	65 W	50 W Min.
Power Flatness @ P _{SAT}	± 0.75 dB	± 1.0 dB Max.
Power Over Temp. @ P _{SAT}	± 1.0 dB	–
Input VSWR	1.2 :1	1.5 :1 Max.
Noise Figure	7 dB	10 dB Max.
2 nd Harmonic @ P _{SAT}	-20 dBc	–
3 rd Harmonic @ P _{SAT}	-11 dBc	–
Spurious Signals (non-harmonic)	< -70 dBc	–
DC Supply Voltage	+28 Volts	+25 to +32 Volts
Current Draw (Quiescent)	700 mA	–
Current Draw @ P _{SAT}	5.1 Amps	5.1 Amps
Switching Time ON/OFF ⁽³⁾	5 μs	10 μs
Package Dimensions	7.98(L) x 4.59(W) x 1.55(H) inches	
Material	6061-T6 Aluminum Alloy	
Finish	Clear Iridite (MIL-DTL-5541F, Class 3)	
Weight (no heatsink)	2.5 lbs (1134 grams)	
RF Connectors	SMA Female (4-Hole Flange)	
DC Interface Connector	15 Pin D-Sub Plug	

Maximum Ratings

Storage Temperature	-45°C to +100°C
Operating Temperature (Case)	-20°C to +80°C
DC Input Voltage	+32 VDC
RF Input Power	+23 dBm

Protection

VSWR Tolerance	10 :1
Case Shut Off Temperature	+85°C

Notes:

1. Specifications are based on measured performance in a 50Ω system.
2. With a nominal input power of +7 dBm.
3. Switching time pertains to an optional blanking function controlled by an LVDS signal.

Outline Drawing

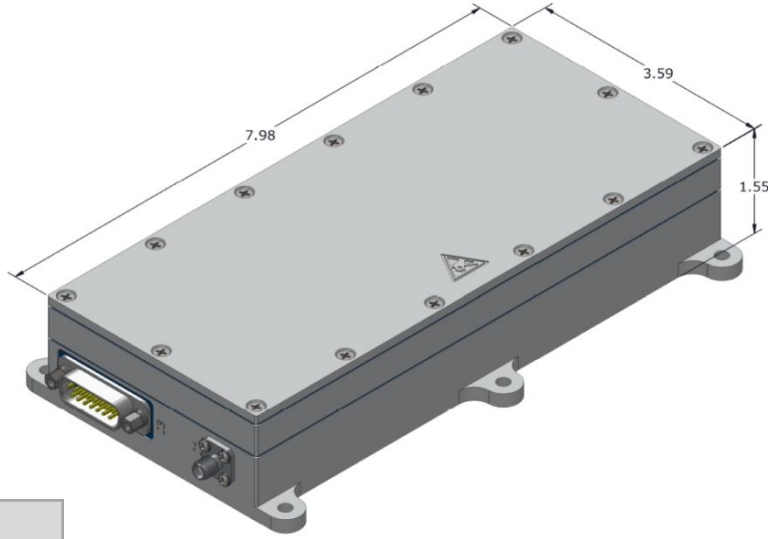
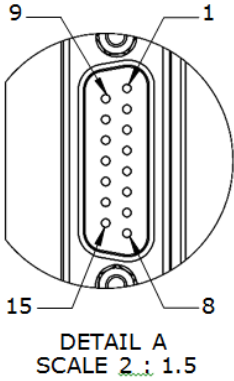
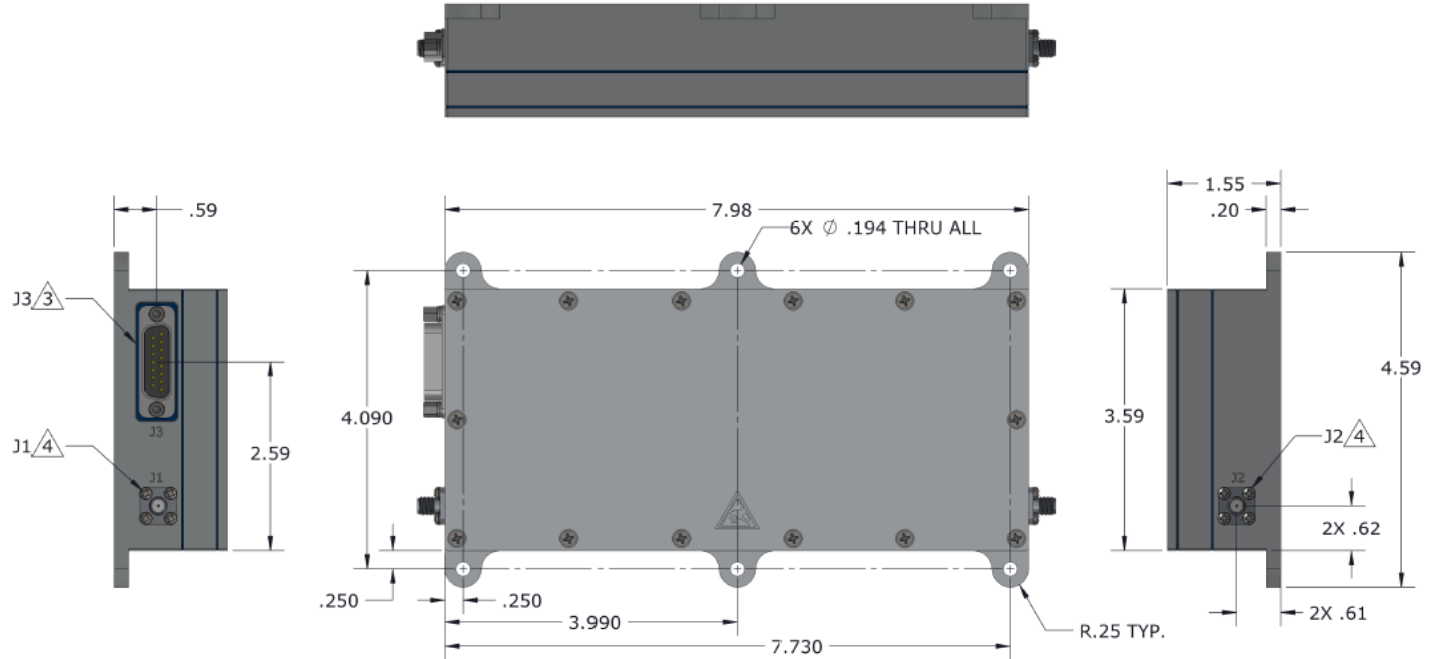

DC Power / Interface (Refer to Detail A)

D-SUB Pin Designations			
Pin #	Signal	Pin #	Signal
1	28V	9	28V RTN
2	28V	10	28V RTN
3	28V	11	28V RTN
4	N/C	12	N/C
5	RESERVED	13	RESERVED
6	N/C	14	BLANKING (-)
7	BLANKING (+)	15	Chassis GND
8	Chassis GND		