

Series  
QFC

RECEPTACLE BOX MOUNT WITH PIN NON-ENVIRONMENTAL INSERT M9 WITH RIGHT ANGLE PC TAIL CONTACTS

Issue:  
Sep. 05, 2019

Page  
1/2

This document contains proprietary information and such information shall not be disclosed to any third party for any purpose whatsoever or used for manufacturing purposes without prior written agreement from RADIALL. This information is given as an indication. In the continual goal to improve our products, we reserve the right to make any modifications judged necessary.

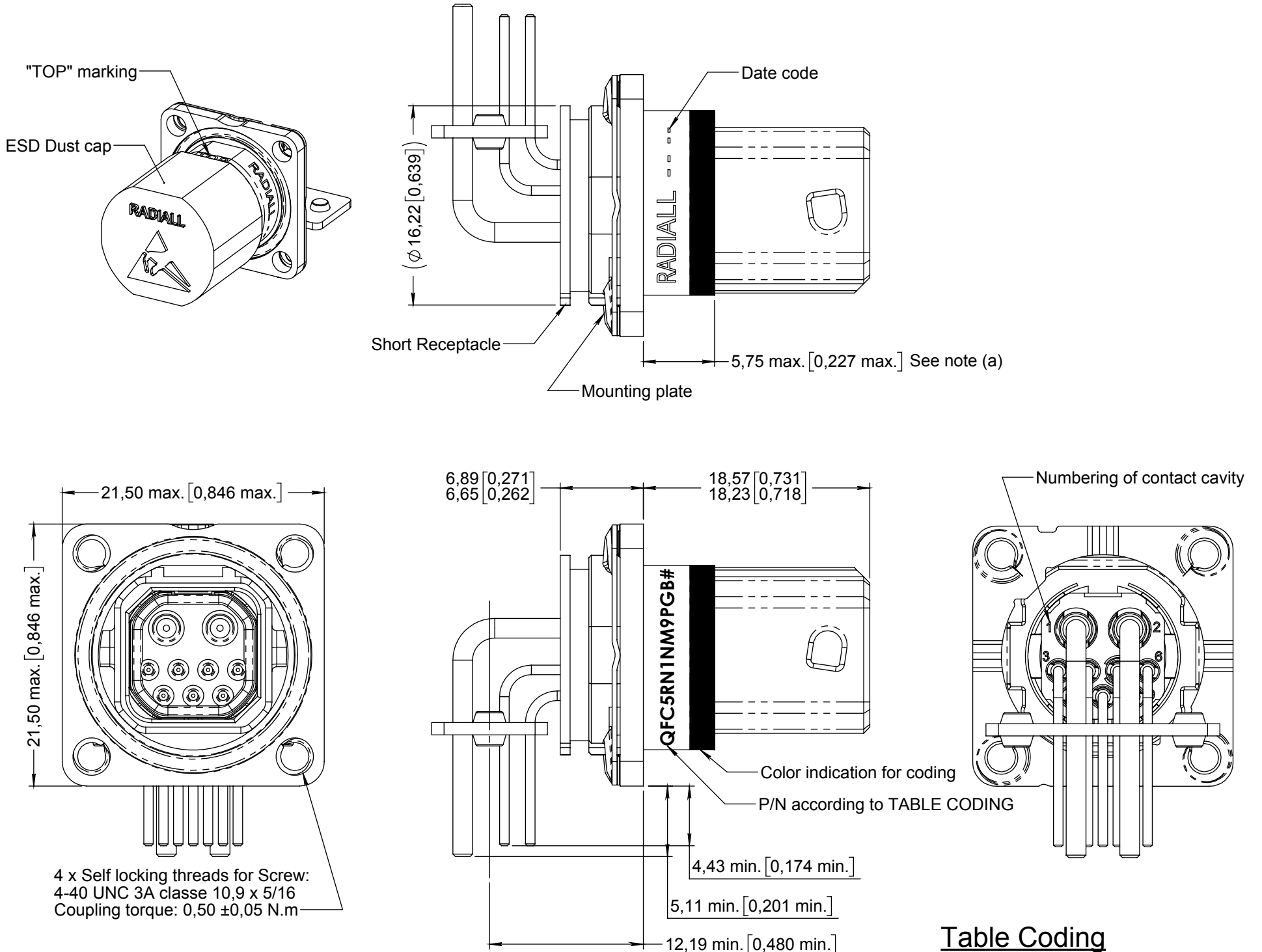

**Table Coding**

Radial P/N	Coding	Color
QFC5RN1NM9PGBA	A	Purple
QFC5RN1NM9PGBB	B	Blue
QFC5RN1NM9PGBC	C	Green
QFC5RN1NM9PGBD	D	Yellow
QFC5RN1NM9PGBE	E	Pink
QFC5RN1NM9PGBF	F	White
QFC5RN1NM9PGBN	N	Black

**I- MATERIALS AND FINISHES:**

- RECEPTACLE SHELL: High grade thermoplastic; nickel plated,
- INSERT RETENTION CLIP: Beryllium copper,
- INSERT: High grade thermoplastic filled, with metallic clips,
- INTERFACIAL SEAL: Fluorosilicone elastomer,
- CONTACT: Copper alloy; gold over nickel,
- MOUNTING PLATE: Stainless steel,
- ESD DUST CAP: Antistatic Thermoplastic.

**II- CONNECTOR SUPPLIED WITH:**

- Non-Environmental M9 insert for pin contacts, installed,
- 7 size 22 right angle PC tail pin contacts, installed,
- 2 size 16 right angle PC tail pin contacts, installed,
- Mounting plate, installed,
- ESD Dust cap; P/N: 627954003, installed.

**III- NOTES:**

- (a) Panel + washer + head screw thickness should not exceed 5,25 max. [0,207 max.],
- Screw + washer kit; P/N: 627990001, not supplied,
- For mounting instruction, refer to MIIN2700003.

**DIMENSIONS : mm (inch are given for information only)**

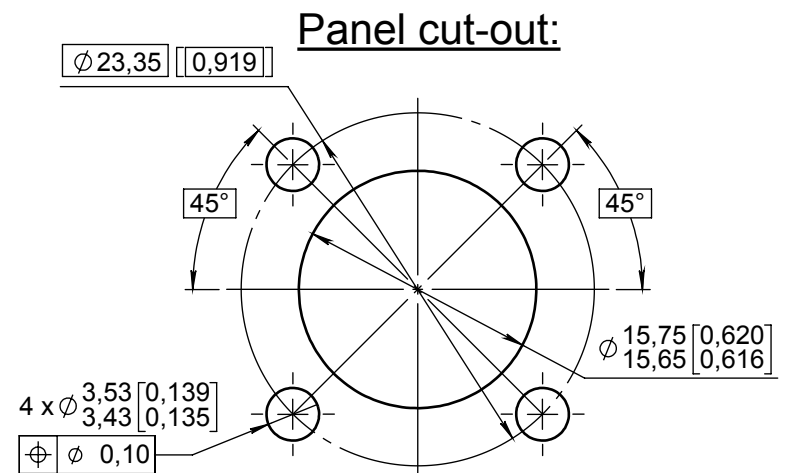
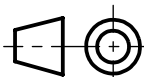

Estimated weight (w/o dust cap) : 10.90 Gr

CREATION				
PEN:				
NOM: LOPEZ C.				
DATE: Sep. 05, 2019				
APPR.: WEIHS H.				
Issue	Revisions	Name	Approved	

MOTHER BOARD GRID PATTERN (Rear view)

[P] = Mother board plane

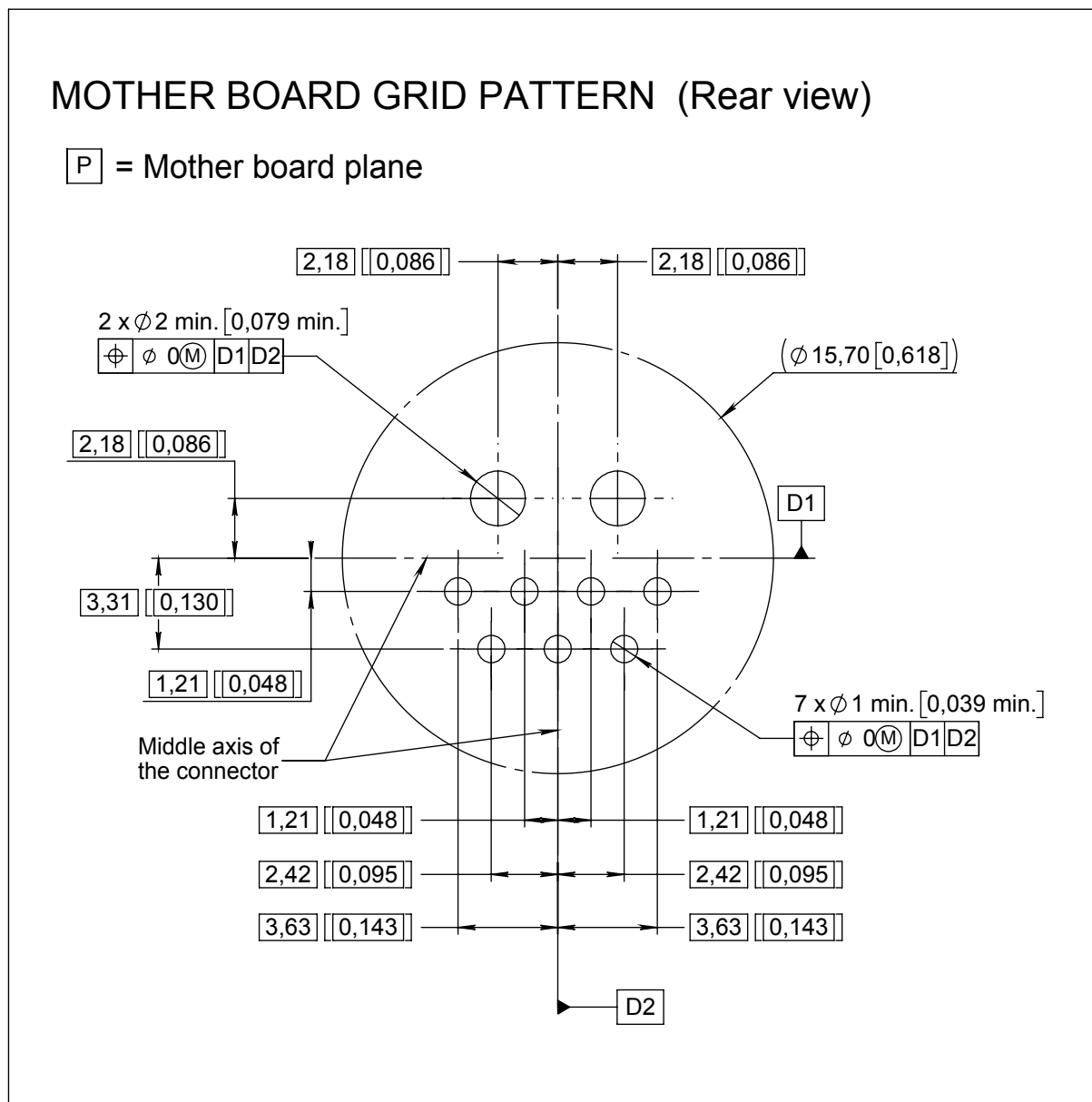

This document contains proprietary information and such information shall not be disclosed to any third party for any purpose whatsoever or used for manufacturing purposes without prior written agreement from RADIALL. This information is given as an indication. In the continual goal to improve our products, we reserve the right to make any modifications judged necessary.

4112\_9311