

QL56 Series Luminescence Sensor



Datasheet

High-performance Luminescence Sensor

To view or download the latest technical information about this product, including specifications, dimensions, accessories, and wiring, see <http://www.bannerengineering.com>.

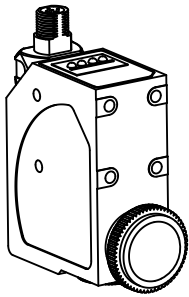

- Senses luminescent marks, even on luminescent backgrounds and irregular or reflective surfaces
- High-power UV emission and a line of structured light provide a uniform and consistent beam for improved sensitivity
- Fast switching frequency and response time
- Push button programming for easy setup and clear bargraph indicator
- Choice of operating distance depending on model
- Durable, compact aluminum housing
- Bipolar (1 NPN and 1 PNP) output, plus 0.75 to 5.5V dc analog output
- 5-position swivel QD connector



WARNING: Not To Be Used for Personnel Protection

Never use this device as a sensing device for personnel protection. Doing so could lead to serious injury or death. This device does not include the self-checking redundant circuitry necessary to allow its use in personnel safety applications. A sensor failure or malfunction can cause either an energized or de-energized sensor output condition.

Models

Model	Operating Distance	Sensor Performance	Cable / Connector	Outputs
QL56M6XD15BQ	10 to 20 mm (0.39 in to 0.79 in)		Integral 5-pin M12/ Euro-style male quick disconnect (QD)	One NPN and PNP discrete plus one 0.75 to 5.5 V dc analog
QL56M6XD30BQ	20 to 40 mm (0.79 in to 1.57 in)			
QL56M6XD40BQ	30 to 50 mm (1.18 in to 1.97 in)			



Overview

The QL56 Series Luminescence Sensor is an easy-to-use, extremely sensitive luminescence sensor that emits ultraviolet (UV) light from high-power LEDs and detects visible light created by luminescent targets. This technology allows for the detection of luminescent marks (even invisible ones) on any surface, independently from its material, color, or distance inside the operating range, as long as the target radiates visible light when illuminated with UV light.

Applications

The QL56 can be used to error-proof manufacturing lines and verify the presence of glues, lubricants, tamper-proof labels, inks, paint, or the inspector's UV mark. There are many applications where the unique property of luminescence can be used to verify that a chemical or adhesive was applied, to inspect for leaks on a seal, or to ensure a critical manufacturing step was completed.

Many materials exhibit luminescence naturally or can be enhanced to include luminescence dyes (also known as luminophores). For example, white bond paper exhibits luminescence under the UV light without any additional treatment. Or a corrosion prevention treatment may be enhanced to include a luminescence dye so that its application can be verified later.

The Advantage of the QL56

The QL56 sensor uses six UV LEDs which create a uniform and intense line of UV light. The structured light allows for reliable detection of luminescence marks on irregular or textured surfaces such as wood, textile, or cast surfaces. The sensor's durable aluminum housing ensures years of use in challenging environments. Most applications can be addressed with the bi-polar discrete outputs, but an analog output signal is available to make subtle pass or fail decisions if greater contrast resolution is required.

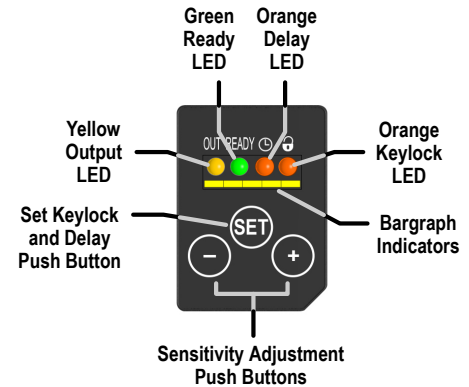

Figure 1. Features

Sensor Configuration

General Notes on Configuration

- The sensor's KEYLOCK function deactivates the push buttons to avoid accidental sensor setting. The push buttons are locked at sensor power-up (KEYLOCK LED OFF). To enable the push buttons, press and hold the SET push button for 5 seconds; there is a 2 minute timeout for the keylock.
- The DELAY SETTING extends the minimum active output status duration to 20 ms, allowing slower interface systems to detect shorter pulses.
- The analog output supplies a voltage proportional to the signal received by the sensor. The voltage supplied is 0.75 to 5.5 V.

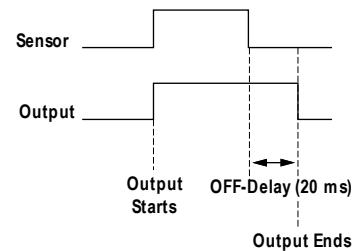
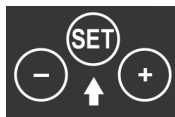
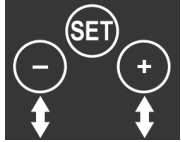

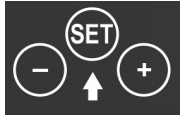



Figure 2. OFF-delay: output continues for 20 ms after sensing stops

	Procedure	Result
Keylock Setting	Press and hold SET push button for 5 seconds (the keyboard will automatically re-lock if inactive for 2 minutes)	Keylock LED: ON



	Procedure		Result
Sensitivity Setting	Click the "+" and "-" push buttons to increase or decrease the sensitivity level. Hold for fast adjustment.		Sensitivity Setting communicated by bar graph indicator 
Delay Setting	Press and hold the SET push button for 2 seconds to toggle off-delay		DELAY LED: ON indicating 20 ms off-delay is active 

Installation

The sensor can be mounted using the Ø3.5 mm housing holes or the threaded M5 holes with 6 mm max. depth. (Warning: the use of excessively long screws can damage the product) The connector can be oriented at five different positions by rotating the block. The position chosen is held by a mechanical blocking system. The rotation can be carried out after sensor installation as the connector block is completely self contained inside the housing.

Specifications

Supply Voltage and Current
15 to 30 V dc (2 V_{pp} maximum ripple); 50 mA maximum at 24 V dc (excluding output current)

Sensing Beam
LED UV, 375 nm; class 1

Sensing Range
QL56M6XD15BQ: 10 to 20 mm (0.39 to 0.79 inches)
QL56M6XD30BQ: 20 to 40 mm (0.79 to 1.57 inches)
QL56M6XD40BQ: 30 to 50 mm (1.18 to 1.97 inches)

Analog Output
0.75 to 5.5 V dc maximum

Analog Output Impedance
2.2 kΩ (short-circuit protection)

Delay
0 ms (default) or 20 ms user selectable

Output Protection Circuitry
Overload and short circuit protection

Output Configuration
Bipolar (1 NPN and 1 PNP), plus 0.75 to 5.5 V dc analog output

Output Rating
100 mA maximum

Output Response Time
250 μs

Output Saturation Voltage
≤ 2 V

Shock Resistance
30 G; 6 shocks per axis; 11 ms duration (EN60068-2-27)

Vibration
Vibration 10 to 55 Hz 0.5 mm p-p amplitude per IEC60068-2-6

Operating Conditions
Temperature: -10 °C to +55 °C (+14 °F to +131 °F)
Storage Temperature: -20 °C to +70 °C (-4 °F to +158 °F)

Supply Protection Circuitry
Protected against reverse polarity

Ambient Light Rejection
According to EN 60947-5-2

Minimum Spot Dimension
2 × 8 mm at 10 mm (QL56M6XD15BQ)
3 × 11 mm at 24 mm (QL56M6XD30BQ)
4 × 15 mm at 50 mm (QL56M6XD40BQ)

Construction
Aluminum housing, glass lens; mass 180 g maximum

Adjustments
"+" and "-" push buttons determine sensitivity
"Set" push button activates delay and keylock function (see [Overview](#) on page 2)

Connections
Integral 5-pin M12/Euro-style male quick disconnect (QD)

Indicators
Yellow OUTPUT LED: ON indicates output conducting
Green READY LED: ON indicates power on; Flashing indicates output overload
Orange DELAY LED: ON indicates 20 ms delay activated
Orange KEYLOCK LED: ON indicates push buttons are unlocked
5-segment bar graph: Indicates sensitivity

Switching Frequency
2 kHz

Environmental Rating
IEC IP67

Application Notes
The lens must be used in the lower position, and the cap must remain in place on the end position

Certification



Dimensions

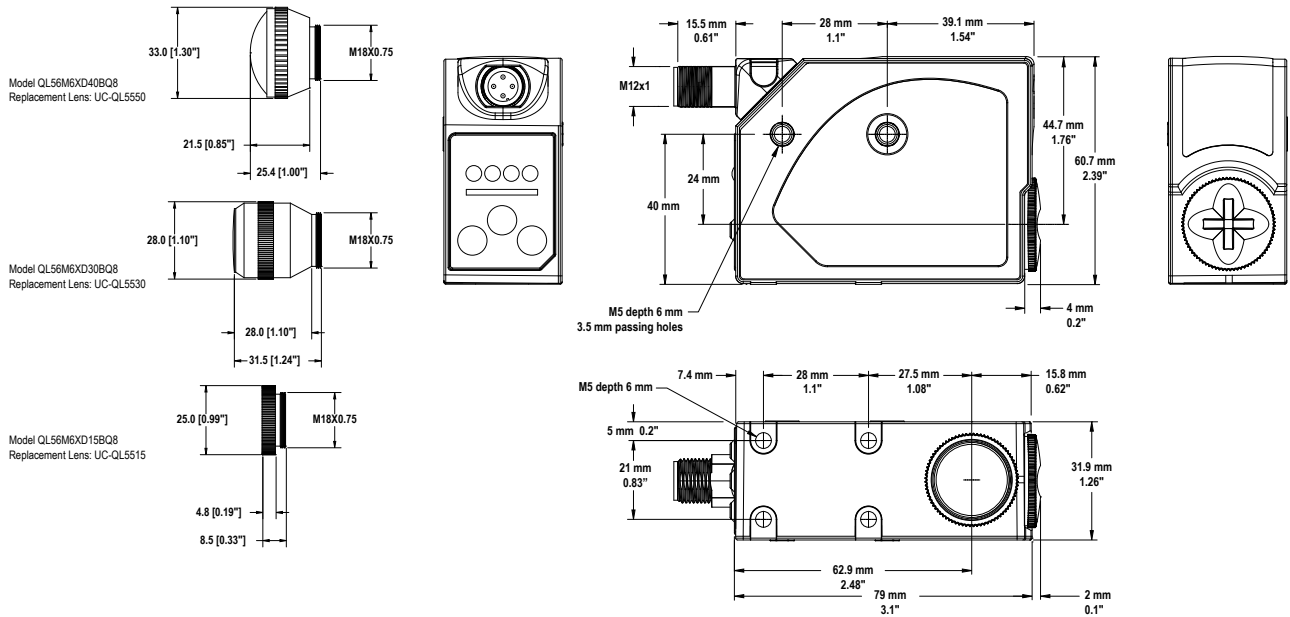

Wiring Diagram

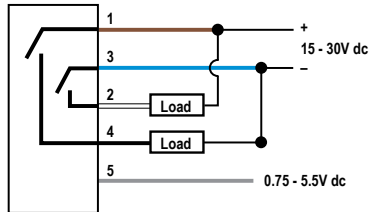

Wiring Key:

- 1 = Brown
- 2 = White
- 3 = Blue
- 4 = Black
- 5 = Gray

Accessories

5-Pin Threaded M12/Euro-Style Cordsets—Single Ended				
Model	Length	Style	Dimensions	Pinout (Female)
MQDC1-501.5	0.50 m (1.5 ft)	Straight		
MQDC1-506	1.83 m (6 ft)			
MQDC1-515	4.57 m (15 ft)			
MQDC1-530	9.14 m (30 ft)			